

MC44603

Advance Information

Mixed Frequency Mode GreenLine™ PWM Controller: Fixed Frequency, Variable Frequency, Standby Mode

The MC44603 is an enhanced high performance controller that is specifically designed for off-line and dc-to-dc converter applications. This device has the unique ability of automatically changing operating modes if the converter output is overloaded, unloaded, or shorted, offering the designer additional protection for increased system reliability. The MC44603 has several distinguishing features when compared to conventional SMPS controllers. These features consist of a foldback facility for overload protection, a standby mode when the converter output is slightly loaded, a demagnetization detection for reduced switching stresses on transistor and diodes, and a high current totem pole output ideally suited for driving a power MOSFET. It can also be used for driving a bipolar transistor in low power converters (< 150 W). It is optimized to operate in discontinuous mode but can also operate in continuous mode. Its advanced design allows use in current mode or voltage mode control applications.

Current or Voltage Mode Controller

- Operation up to 250 kHz Output Switching Frequency
- Inherent Feed Forward Compensation
- Latching PWM for Cycle-by-Cycle Current Limiting
- Oscillator with Precise Frequency Control

High Flexibility

- Externally Programmable Reference Current
- Secondary or Primary Sensing
- Synchronization Facility
- High Current Totem Pole Output
- Undervoltage Lockout with Hysteresis

Safety/Protection Features

- Overvoltage Protection Against Open Current and Open Voltage Loop
- Protection Against Short Circuit on Oscillator Pin
- Fully Programmable Foldback
- Soft-Start Feature
- Accurate Maximum Duty Cycle Setting
- Demagnetization (Zero Current Detection) Protection
- Internally Trimmed Reference

GreenLine Controller: Low Power Consumption in Standby Mode

- Low Startup and Operating Current
- Fully Programmable Standby Mode
- Controlled Frequency Reduction in Standby Mode
- Low dV/dT for Low EMI Radiations

MIXED FREQUENCY MODE GREENLINE PWM* CONTROLLER:

VARIABLE FREQUENCY, FIXED FREQUENCY, STANDBY MODE

* PWM = Pulse Width Modulation

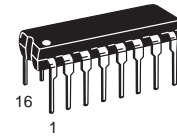

P SUFFIX
PLASTIC PACKAGE
CASE 648

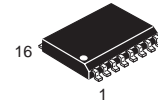

DW SUFFIX
PLASTIC PACKAGE
CASE 751G
(SOP-16L)

PIN CONNECTIONS

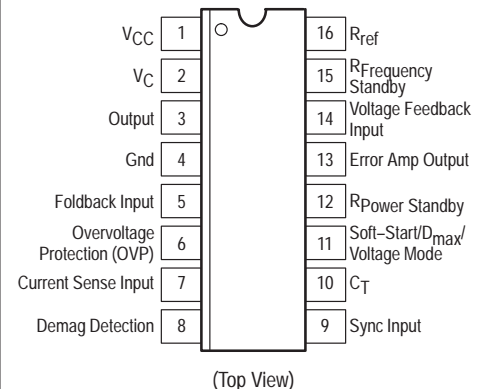

ORDERING INFORMATION

Device	Operating Temperature Range	Package
MC44603P	T _A = -25° to +85°C	Plastic DIP-16
MC44603DW		SOP-16L

MAXIMUM RATINGS

Rating	Symbol	Value	Unit
Total Power Supply and Zener Current	$(I_{CC} + I_Z)$	30	mA
Supply Voltage with Respect to Ground (Pin 4)	V_C V_{CC}	18	V
Output Current (Note 1) Source Sink	$I_{O(\text{Source})}$ $I_{O(\text{Sink})}$	-750 750	mA
Output Energy (Capacitive Load per Cycle)	W	5.0	μJ
R _F Stby, C _T , Soft-Start, R _{ref} , R _P Stby Inputs	V_{in}	-0.3 to 5.5	V
Foldback Input, Current Sense Input, E/A Output, Voltage Feedback Input, Overvoltage Protection, Synchronization Input	V_{in}	-0.3 to $V_{CC} + 0.3$	V
Synchronization Input High State Voltage Low State Reverse Current	V_{IH} V_{IL}	$V_{CC} + 0.3$ -20	V mA
Demagnetization Detection Input Current Source Sink	$I_{\text{demag-ib (Source)}}$ $I_{\text{demag-ib (Sink)}}$	-4.0 10	mA
Error Amplifier Output Sink Current	$I_{E/A (\text{Sink})}$	20	mA
Power Dissipation and Thermal Characteristics P Suffix, Dual-In-Line, Case 648 Maximum Power Dissipation at $T_A = 85^\circ\text{C}$ Thermal Resistance, Junction-to-Air DW Suffix, Surface Mount, Case 751G Maximum Power Dissipation at $T_A = 85^\circ\text{C}$ Thermal Resistance, Junction-to-Air	P_D $R_{\theta JA}$ P_D $R_{\theta JA}$	0.6 100 0.45 145	W $^\circ\text{C/W}$ W $^\circ\text{C/W}$
Operating Junction Temperature	T_J	150	$^\circ\text{C}$
Operating Ambient Temperature	T_A	-25 to +85	$^\circ\text{C}$

NOTES: 1. Maximum package power dissipation limits must be observed.
2. ESD data available upon request.

ELECTRICAL CHARACTERISTICS (V_{CC} and $V_C = 12\text{ V}$, [Note 3], $R_{ref} = 10\text{ k}\Omega$, $C_T = 820\text{ pF}$, for typical values $T_A = 25^\circ\text{C}$, for min/max values $T_A = -25^\circ\text{C}$ to $+85^\circ\text{C}$ [Note 4], unless otherwise noted.)

Characteristic	Symbol	Min	Typ	Max	Unit
----------------	--------	-----	-----	-----	------

OUTPUT SECTION

Output Voltage (Note 5) Low State ($I_{\text{Sink}} = 100\text{ mA}$) ($I_{\text{Sink}} = 500\text{ mA}$) High State ($I_{\text{Source}} = 200\text{ mA}$) ($I_{\text{Source}} = 500\text{ mA}$)	V_{OL} V_{OH}	- - - -	1.0 1.4 1.5 2.0	1.2 2.0 2.0 2.7	V
Output Voltage During Initialization Phase $V_{CC} = 0$ to 1.0 V , $I_{\text{Sink}} = 10\text{ }\mu\text{A}$ $V_{CC} = 1.0$ to 5.0 V , $I_{\text{Sink}} = 100\text{ }\mu\text{A}$ $V_{CC} = 5.0$ to 13 V , $I_{\text{Sink}} = 1.0\text{ mA}$	V_{OL}	- - -	- 0.1 0.1	1.0 1.0 1.0	V
Output Voltage Rising Edge Slew-Rate ($C_L = 1.0\text{ nF}$, $T_J = 25^\circ\text{C}$)	dV_o/dT	-	300	-	$\text{V}/\mu\text{s}$
Output Voltage Falling Edge Slew-Rate ($C_L = 1.0\text{ nF}$, $T_J = 25^\circ\text{C}$)	dV_o/dT	-	-300	-	$\text{V}/\mu\text{s}$

ERROR AMPLIFIER SECTION

Voltage Feedback Input ($V_{E/A \text{ out}} = 2.5\text{ V}$)	V_{FB}	2.42	2.5	2.58	V
Input Bias Current ($V_{FB} = 2.5\text{ V}$)	I_{FB-ib}	-2.0	-0.6	-	μA
Open Loop Voltage Gain ($V_{E/A \text{ out}} = 2.0$ to 4.0 V)	A_{VOL}	65	70	-	dB

NOTES: 3. Adjust V_{CC} above the startup threshold before setting to 12 V .
4. Low duty cycle pulse techniques are used during test to maintain junction temperature as close to ambient as possible.
5. V_C must be greater than 5.0 V .

ELECTRICAL CHARACTERISTICS (continued) (V_{CC} and $V_C = 12$ V, [Note 3], $R_{ref} = 10$ k Ω , $C_T = 820$ pF, for typical values $T_A = 25^\circ\text{C}$, for min/max values $T_A = -25^\circ$ to $+85^\circ\text{C}$ [Note 4], unless otherwise noted.)

Characteristic	Symbol	Min	Typ	Max	Unit
----------------	--------	-----	-----	-----	------

ERROR AMPLIFIER SECTION (continued)

Unity Gain Bandwidth $T_J = 25^\circ\text{C}$ $T_J = -25^\circ$ to $+85^\circ\text{C}$	BW	–	4.0	–	MHz
Voltage Feedback Input Line Regulation ($V_{CC} = 10$ to 15 V)	$V_{FBline-reg}$	–10	–	10	mV
Output Current Sink ($V_{E/A out} = 1.5$ V, $V_{FB} = 2.7$ V) $T_A = -25^\circ$ to $+85^\circ\text{C}$ Source ($V_{E/A out} = 5.0$ V, $V_{FB} = 2.3$ V) $T_A = -25^\circ$ to $+85^\circ\text{C}$	I_{Sink} I_{Source}	2.0 –2.0	12 –	– –0.2	mA
Output Voltage Swing High State ($I_{E/A out (source)} = 0.5$ mA, $V_{FB} = 2.3$ V) Low State ($I_{E/A out (sink)} = 0.33$ mA, $V_{FB} = 2.7$ V)	V_{OH} V_{OL}	5.5 –	6.5 1.0	7.5 1.1	V

REFERENCE SECTION

Reference Output Voltage ($V_{CC} = 10$ to 15 V)	V_{ref}	2.4	2.5	2.6	V
Reference Current Range ($I_{ref} = V_{ref}/R_{ref}$, $R = 5.0$ k to 25 k Ω)	I_{ref}	–500	–	–100	μA
Reference Voltage Over I_{ref} Range	ΔV_{ref}	–40	–	40	mV

OSCILLATOR AND SYNCHRONIZATION SECTION

Frequency $T_A = 0^\circ$ to $+70^\circ\text{C}$ $T_A = -25^\circ$ to $+85^\circ\text{C}$	f_{OSC}	44.5 44	48 –	51.5 52	kHz
Frequency Change with Voltage ($V_{CC} = 10$ to 15 V)	$\Delta f_{OSC}/\Delta V$	–	0.05	–	%/V
Frequency Change with Temperature ($T_A = -25^\circ$ to $+85^\circ\text{C}$)	$\Delta f_{OSC}/\Delta T$	–	0.05	–	%/ $^\circ\text{C}$
Oscillator Voltage Swing (Peak-to-Peak)	$V_{OSC(pp)}$	1.65	1.8	1.95	V
Ratio Charge Current/Reference Current $T_A = 0^\circ$ to $+70^\circ\text{C}$ ($V_{CT} = 2.0$ V) $T_A = -25^\circ$ to $+85^\circ\text{C}$	I_{charge}/I_{ref}	0.375 0.37	0.4 –	0.425 0.43	–
Fixed Maximum Duty Cycle = $I_{discharge}/(I_{discharge} + I_{charge})$	D	78	80	82	%
Ratio Standby Discharge Current versus $I_{RF Stby}$ (Note 6) $T_A = 0^\circ$ to $+70^\circ\text{C}$ $T_A = -25^\circ$ to $+85^\circ\text{C}$ (Note 8)	$I_{disch-Stby}/I_{RF Stby}$	0.46 0.43	0.53 –	0.6 0.63	–
$V_{RF Stby}$ ($I_{RF Stby} = 100$ μA)	$V_{RF Stby}$	2.4	2.5	2.6	V
Frequency in Standby Mode ($R_{F Stby}$ (Pin 15) = 25 k Ω)	f_{Stby}	18	21	24	kHz
Current Range	$I_{RF Stby}$	–200	–	–50	μA
Synchronization Input Threshold Voltage (Note 7)	V_{inthH} V_{inthL}	3.2 0.45	3.7 0.7	4.3 0.9	V
Synchronization Input Current	$I_{Sync-in}$	–5.0	–	0	μA
Minimum Synchronization Pulse Width (Note 8)	T_{Sync}	–	–	0.5	μs

UNDERVOLTAGE LOCKOUT SECTION

Startup Threshold	$V_{stup-th}$	13.6	14.5	15.4	V
Output Disable Voltage After Threshold Turn-On (UVLO 1) $T_A = 0^\circ$ to $+70^\circ\text{C}$ $T_A = -25^\circ$ to $+85^\circ\text{C}$	$V_{disable1}$	8.6 8.3	9.0 –	9.4 9.6	V
Reference Disable Voltage After Threshold Turn-On (UVLO 2)	$V_{disable2}$	7.0	7.5	8.0	V

- NOTES:**
- Adjust V_{CC} above the startup threshold before setting to 12 V.
 - Low duty cycle pulse techniques are used during test to maintain junction temperature as close to ambient as possible.
 - Standby is disabled for $V_{RP Stby} < 25$ mV typical.
 - If not used, Synchronization input must be connected to Ground.
 - Synchronization Pulse Width must be shorter than $T_{OSC} = 1/f_{OSC}$.

MC44603

ELECTRICAL CHARACTERISTICS (continued) (V_{CC} and $V_C = 12$ V, [Note 3], $R_{ref} = 10$ k Ω , $C_T = 820$ pF, for typical values $T_A = 25^\circ\text{C}$, for min/max values $T_A = -25^\circ$ to $+85^\circ\text{C}$ [Note 4], unless otherwise noted.)

Characteristic	Symbol	Min	Typ	Max	Unit
----------------	--------	-----	-----	-----	------

DEMAGNETIZATION DETECTION SECTION (Note 9)

Demagnetization Detect Input					
Demagnetization Comparator Threshold ($V_{Pin\ 9}$ Decreasing)	$V_{demag-th}$	50	65	80	mV
Propagation Delay (Input to Output, Low to High)	–	–	0.25	–	μs
Input Bias Current ($V_{demag} = 65$ mV)	$I_{demag-lb}$	–0.5	–	–	μA
Negative Clamp Level ($I_{demag} = -2.0$ mA)	$C_{L(neg)}$	–	–0.38	–	V
Positive Clamp Level ($I_{demag} = 2.0$ mA)	$C_{L(pos)}$	–	0.72	–	V

SOFT-START SECTION (Note 11)

Ratio Charge Current/ I_{ref} $T_A = 0^\circ$ to $+70^\circ\text{C}$ $T_A = -25^\circ$ to $+85^\circ\text{C}$	$I_{ss(ch)}/I_{ref}$	0.37 0.36	0.4 –	0.43 0.44	–
Discharge Current ($V_{soft-start} = 1.0$ V)	$I_{discharge}$	1.5	5.0	–	mA
Clamp Level	$V_{ss(CL)}$	2.2	2.4	2.6	V
Duty Cycle ($R_{soft-start} = 12$ k Ω) ($V_{soft-start}$ (Pin 11) = 0.1 V)	$D_{soft-start\ 12k}$ $D_{soft-start}$	36 –	42 –	49 0	%

OVERVOLTAGE SECTION

Protection Threshold Level on V_{OVP}	V_{OVP-th}	2.42	2.5	2.58	V
Propagation Delay ($V_{OVP} > 2.58$ V to V_{out} Low)		1.0	–	3.0	μs
Protection Level on V_{CC} $T_A = 0^\circ$ to $+70^\circ\text{C}$ $T_A = -25^\circ$ to $+85^\circ\text{C}$	$V_{CC\ prot}$	16.1 15.9	17 –	17.9 18.1	V
Input Resistance $T_A = 0^\circ$ to $+70^\circ\text{C}$ $T_A = -25^\circ$ to $+85^\circ\text{C}$	–	1.5 1.4	2.0 –	3.0 3.4	k Ω

FOLDBACK SECTION (Note 10)

Current Sense Voltage Threshold ($V_{foldback}$ (Pin 5) = 0.9 V)	V_{CS-th}	0.86	0.89	0.9	V
Foldback Input Bias Current ($V_{foldback}$ (Pin 5) = 0 V)	$I_{foldback-lb}$	–6.0	–2.0	–	μA

STANDBY SECTION

Ratio $I_{R\ P\ Stby}/I_{ref}$ $T_A = 0^\circ$ to $+70^\circ\text{C}$ $T_A = -25^\circ$ to $+85^\circ\text{C}$	$I_{R\ P\ Stby}/I_{ref}$	0.37 0.36	0.4 –	0.43 0.44	–
Ratio Hysteresis (V_H Required to Return to Normal Operation from Standby Operation) $T_A = 0^\circ$ to $+70^\circ\text{C}$ $T_A = -25^\circ$ to $+85^\circ\text{C}$	$V_H/V_{R\ P\ Stby}$	1.42 1.4	1.5 –	1.58 1.6	–
Current Sense Voltage Threshold ($V_{R\ P\ Stby}$ (Pin 12) = 1.0 V)	$V_{CS-Stby}$	0.28	0.31	0.34	V

CURRENT SENSE SECTION

Maximum Current Sense Input Threshold ($V_{feedback}$ (Pin 14) = 2.3 V and $V_{foldback}$ (Pin 6) = 1.2 V)	V_{CS-th}	0.96	1.0	1.04	V
Input Bias Current	I_{CS-ib}	–10	–2.0	–	μA
Propagation Delay (Current Sense Input to Output at V_{TH} of MOS transistor = 3.0 V)	–	–	120	200	ns

TOTAL DEVICE

Power Supply Current Startup ($V_{CC} = 13$ V with V_{CC} Increasing) Operating $T_A = -25^\circ$ to $+85^\circ\text{C}$ (Note 3)	I_{CC}	– 13	0.3 17	0.45 20	mA
Power Supply Zener Voltage ($I_{CC} = 25$ mA)	V_Z	18.5	–	–	V
Thermal Shutdown	–	–	155	–	$^\circ\text{C}$

NOTES: 3. Adjust V_{CC} above the startup threshold before setting to 12 V.

4. Low duty cycle pulse techniques are used during test to maintain junction temperature as close to ambient as possible.

9. This function can be inhibited by connecting Pin 8 to Gnd. This allows a continuous current mode operation.

10. This function can be inhibited by connecting Pin 5 to V_{CC} .

11. The MC44603 can be shut down by connecting the Soft-Start pin (Pin 11) to Ground.

MC44603

Representative Block Diagram

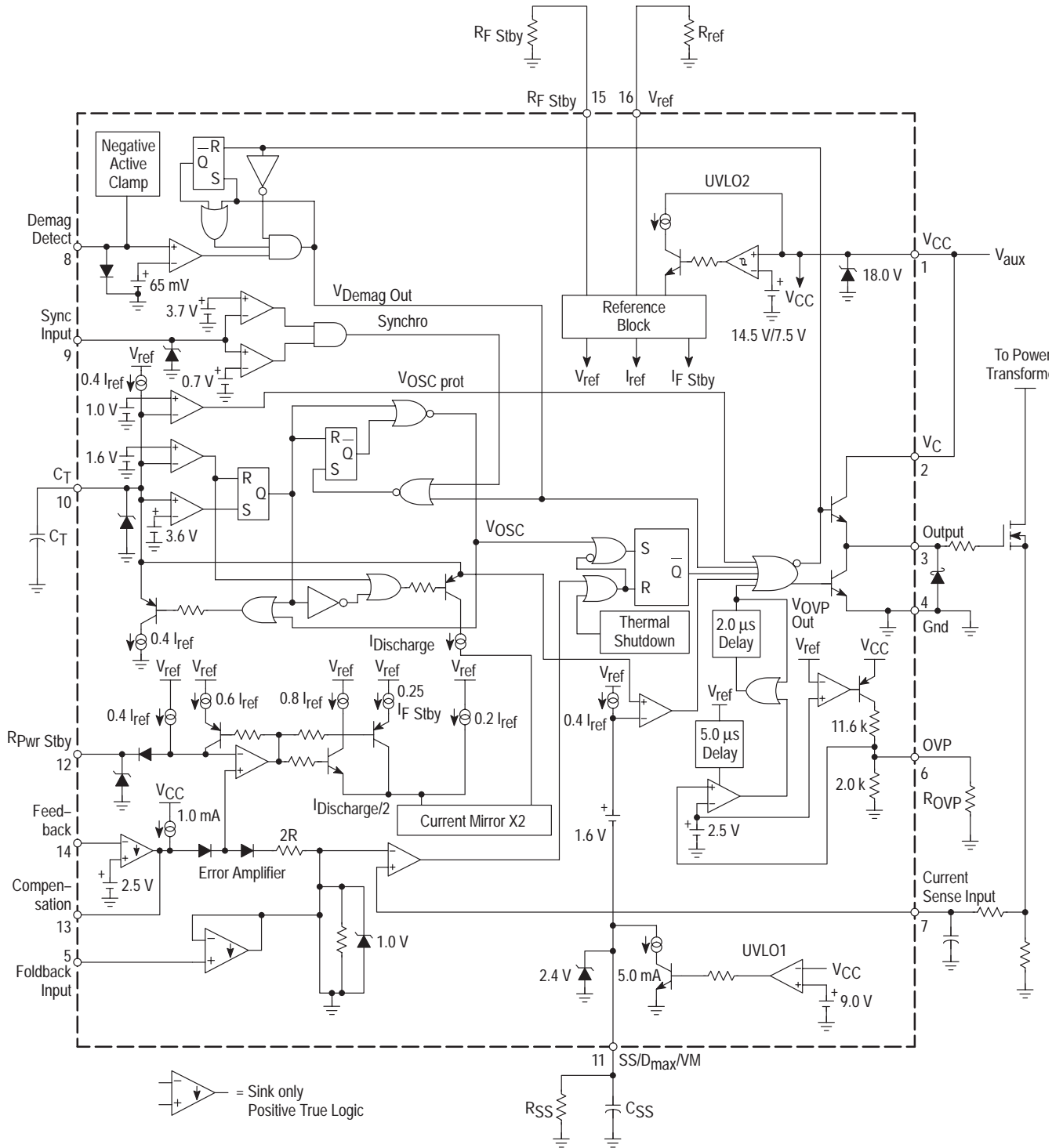

This device contains 243 active transistors.

Figure 1. Timing Resistor versus Oscillator Frequency

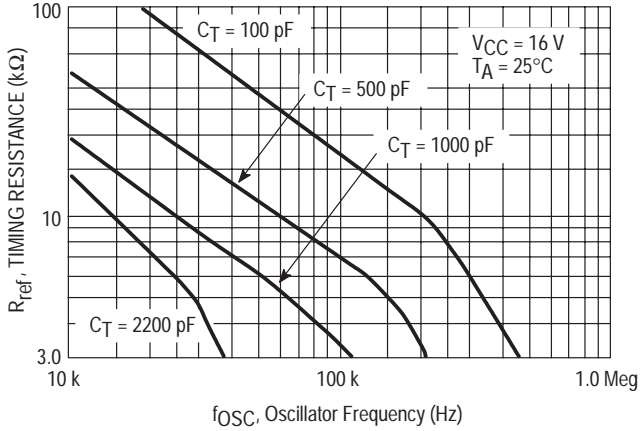

Figure 2. Standby Mode Timing Capacitor versus Oscillator Frequency

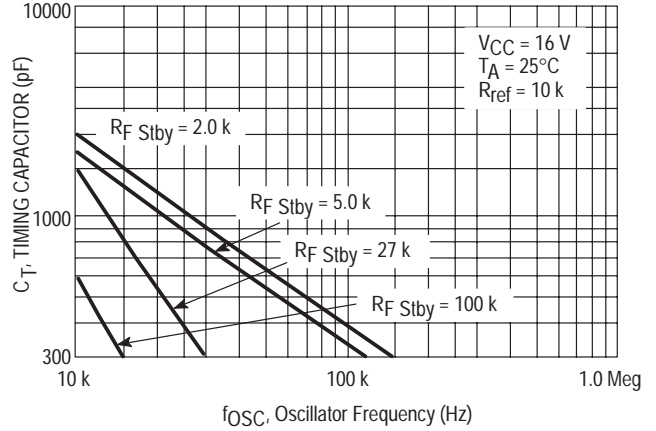

Figure 3. Oscillator Frequency versus Temperature

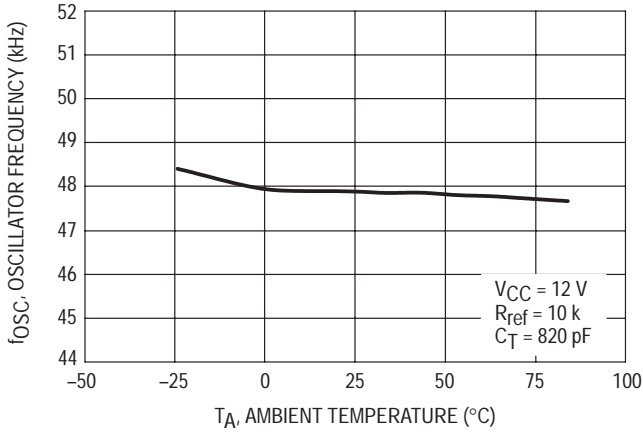

Figure 4. Ratio Charge Current/Reference Current versus Temperature

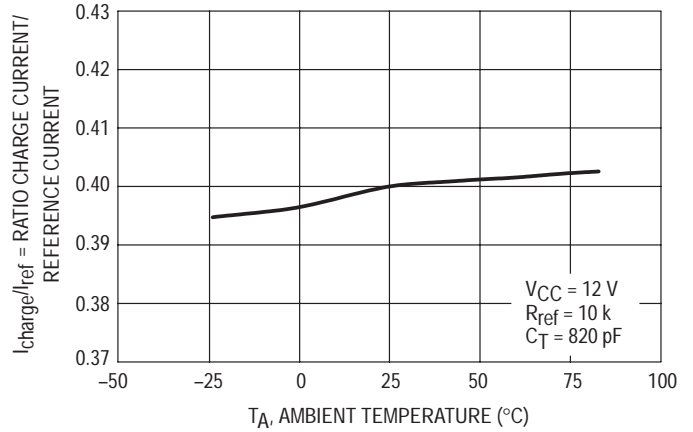

Figure 5. Output Waveform

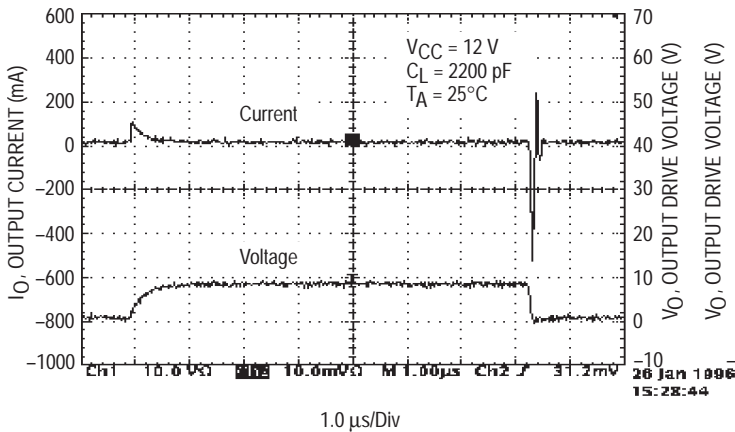

Figure 6. Output Cross Conduction

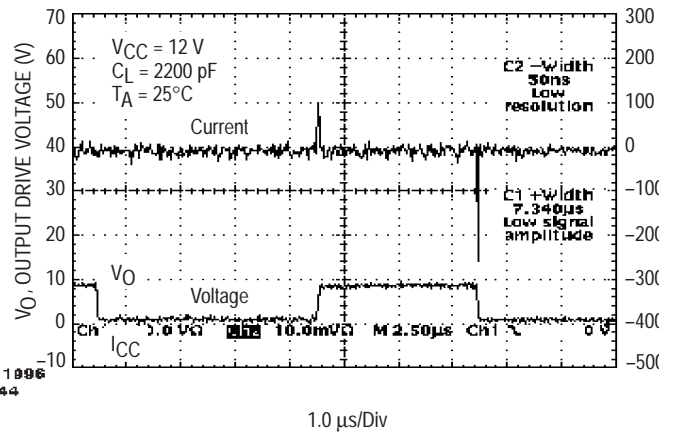

Figure 7. Oscillator Discharge Current versus Temperature

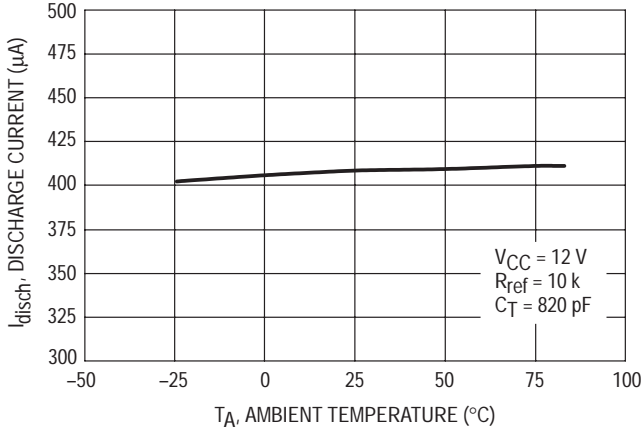

Figure 8. Source Output Saturation Voltage versus Load Current

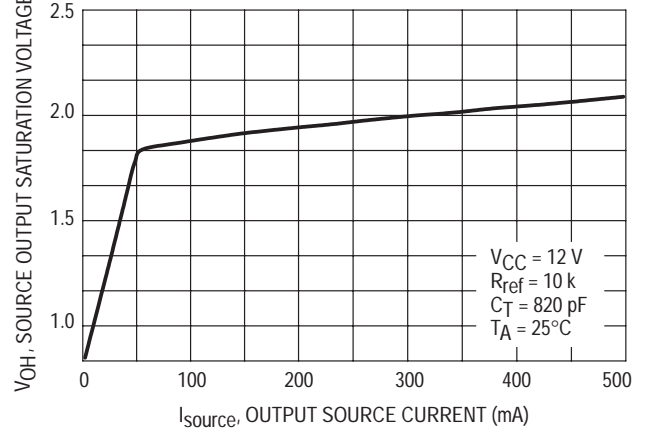

Figure 9. Sink Output Saturation Voltage versus Sink Current

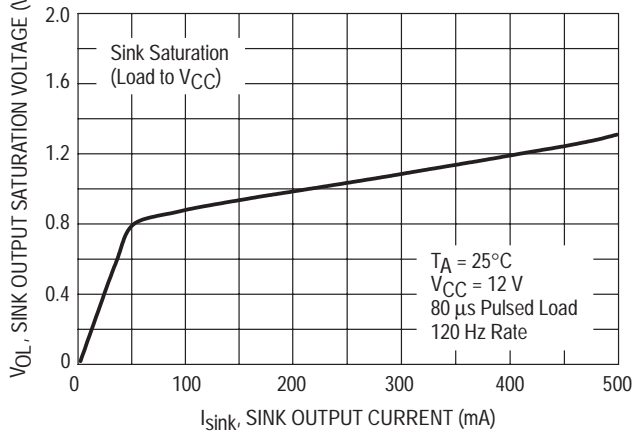

Figure 10. Error Amplifier Gain and Phase versus Frequency

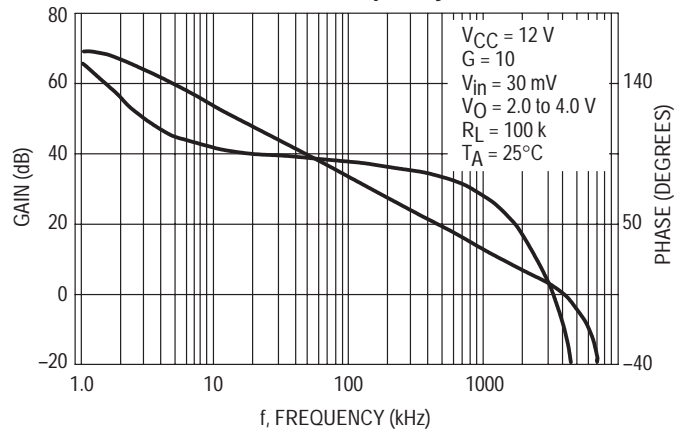

Figure 11. Voltage Feedback Input versus Temperature

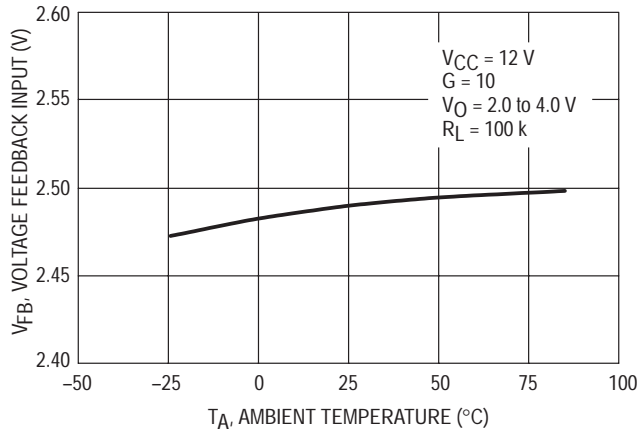

Figure 12. Demag Comparator Threshold versus Temperature

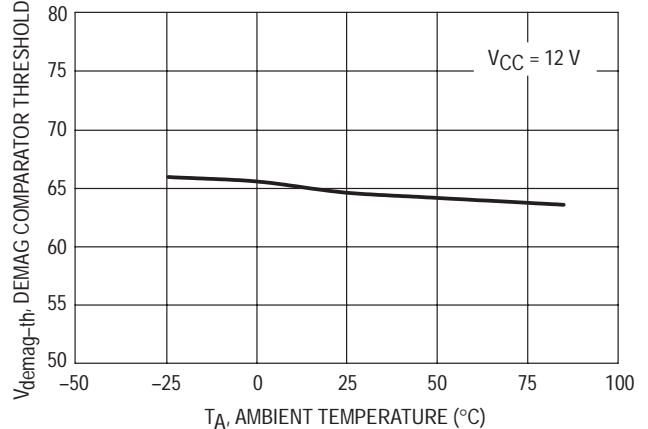

Figure 13. Current Sense Gain versus Temperature

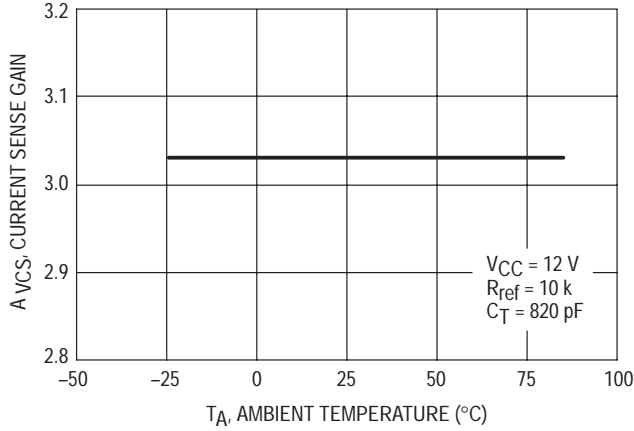

Figure 14. Thermal Resistance and Maximum Power Dissipation versus P.C.B. Copper Length

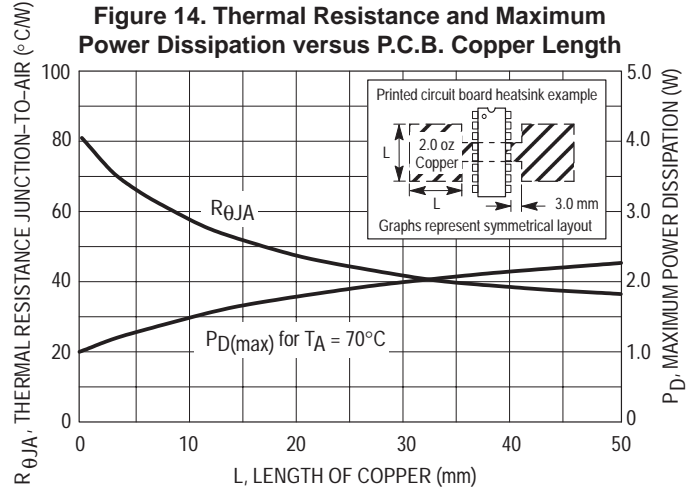

Figure 15. Propagation Delay Current Sense Input to Output versus Temperature

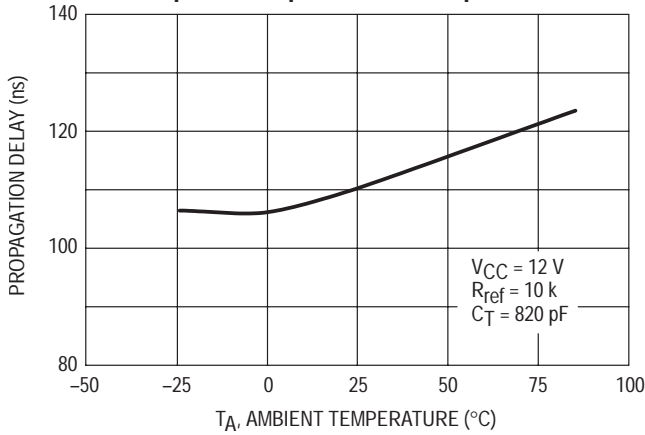

Figure 16. Startup Current versus VCC

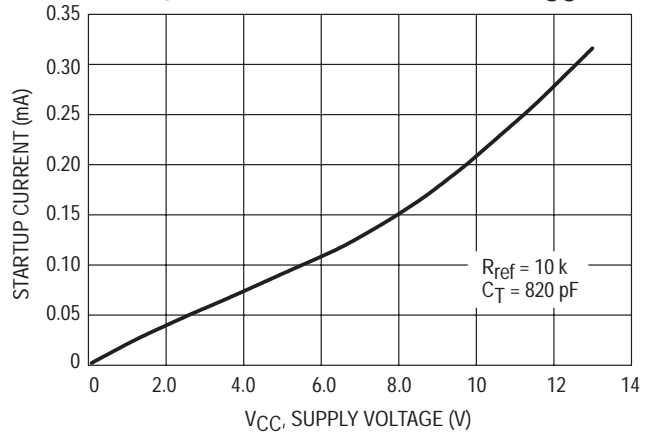

Figure 17. Supply Current versus Supply Voltage

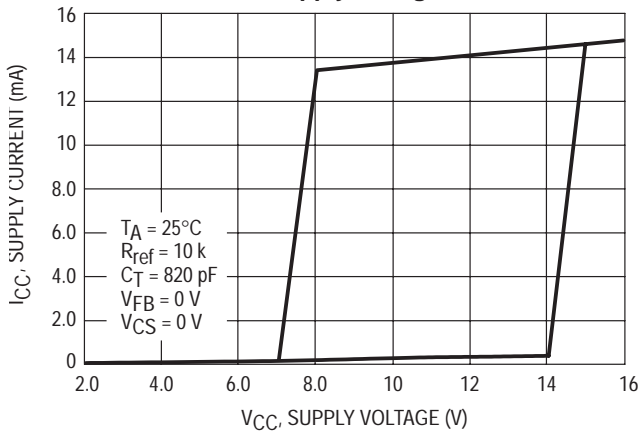

Figure 18. Power Supply Zener Voltage versus Temperature

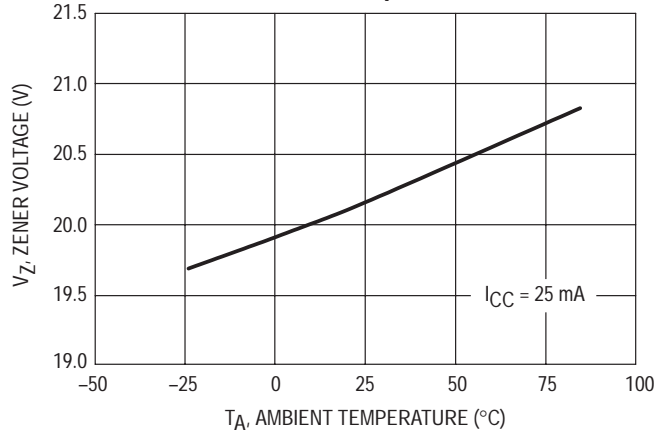

Figure 19. Startup Threshold Voltage versus Temperature

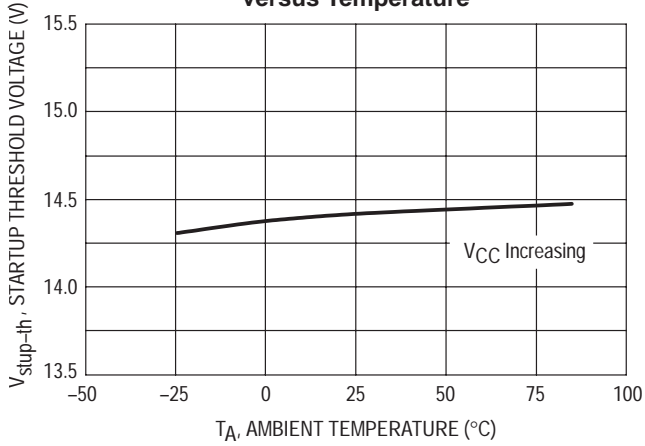

Figure 20. Disable Voltage After Threshold Turn-On (UVLO1) versus Temperature

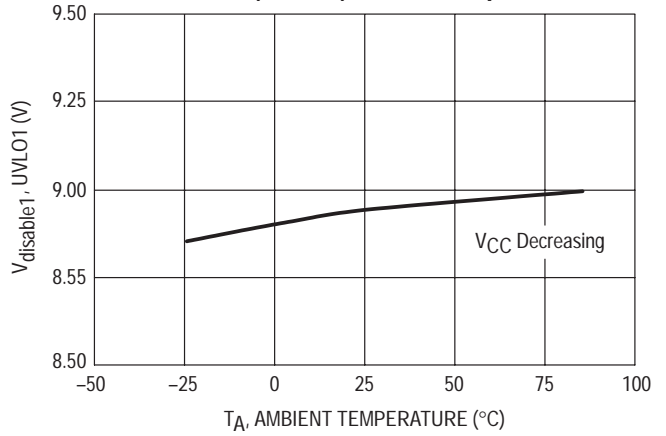

Figure 21. Disable Voltage After Threshold Turn-On (UVLO2) versus Temperature

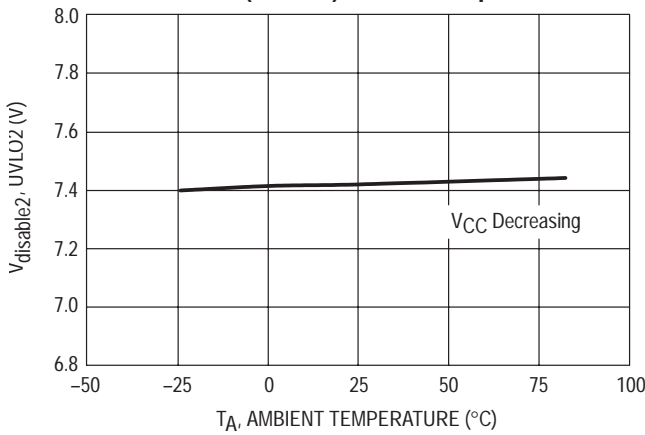

Figure 22. Protection Threshold Level on V_{OVP} versus Temperature

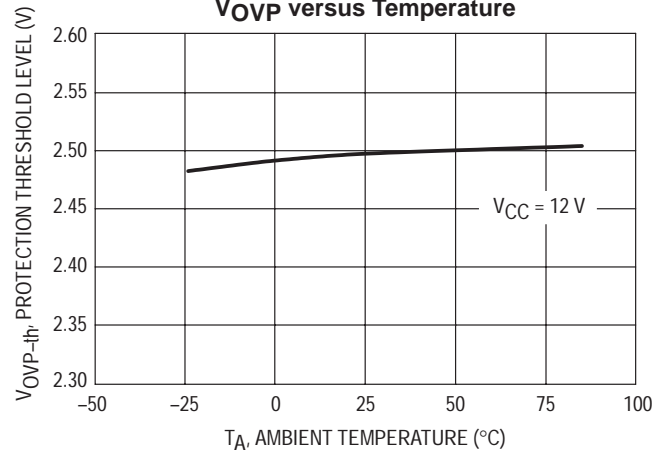

Figure 23. Protection Level on V_{CC} versus Temperature

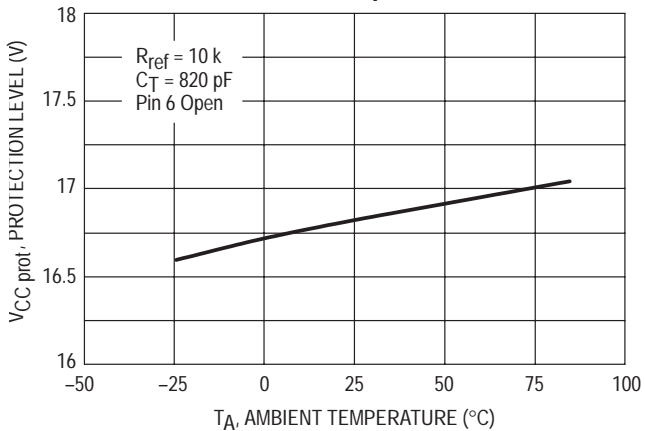

Figure 24. Propagation Delay (V_{OVP} > 2.58 V to V_{out} Low) versus Temperature

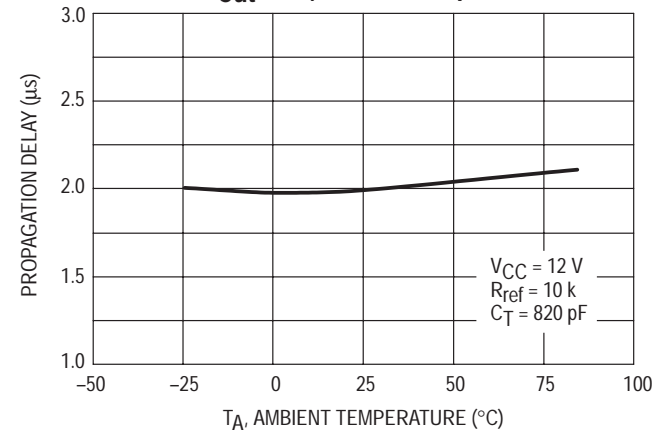

Figure 25. Standby Reference Current versus Temperature

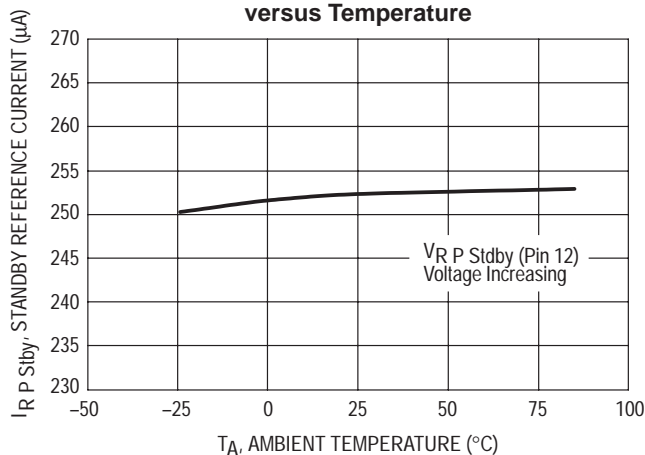
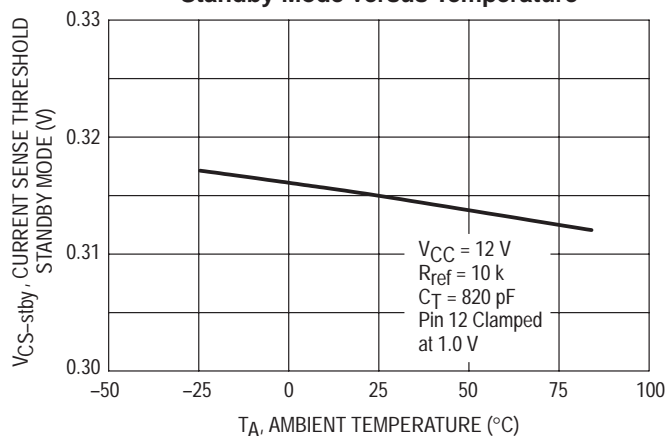

Figure 26. Current Sense Voltage Threshold Standby Mode versus Temperature



PIN FUNCTION DESCRIPTION

Pin	Name	Description
1	V_{CC}	This pin is the positive supply of the IC. The operating voltage range after startup is 9.0 to 14.5 V.
2	V_C	The output high state (V_{OH}) is set by the voltage applied to this pin. With a separate connection to the power source, it can reduce the effects of switching noise on the control circuitry.
3	Output	Peak currents up to 750 mA can be sourced or sunk, suitable for driving either MOSFET or Bipolar transistors. This output pin must be shunted by a Schottky diode, 1N5819 or equivalent.
4	Gnd	The ground pin is a single return, typically connected back to the power source; it is used as control and power ground.
5	Foldback Input	The foldback function provides overload protection. Feeding the foldback input with a portion of the V_{CC} voltage (1.0 V max) establishes on the system control loop a foldback characteristic allowing a smoother startup and sharper overload protection. Above 1.0 V the foldback input is inactive.
6	Overvoltage Protection	When the overvoltage protection pin receives a voltage greater than 17 V, the device is disabled and requires a complete restart sequence. The overvoltage level is programmable.
7	Current Sense Input	A voltage proportional to the current flowing into the power switch is connected to this input. The PWM latch uses this information to terminate the conduction of the output buffer when working in a current mode of operation. A maximum level of 1.0 V allows either current or voltage mode operation.
8	Demagnetization Detection	A voltage delivered by an auxiliary transformer winding provides to the demagnetization pin an indication of the magnetization state of the flyback transformer. A zero voltage detection corresponds to complete core saturation. The demagnetization detection ensures a discontinuous mode of operation. This function can be inhibited by connecting Pin 8 to Gnd.
9	Synchronization Input	The synchronization input pin can be activated with either a negative pulse going from a level between 0.7 V and 3.7 V to Gnd or a positive pulse going from a level between 0.7 V and 3.7 V up to a level higher than 3.7 V. The oscillator runs free when Pin 9 is connected to Gnd.
10	C_T	The normal mode oscillator frequency is programmed by the capacitor C_T choice together with the R_{ref} resistance value. C_T , connected between Pin 10 and Gnd, generates the oscillator sawtooth.
11	Soft-Start/ D_{max} /Voltage-Mode	A capacitor, resistor or a voltage source connected to this pin limits the switching duty-cycle. This pin can be used as a voltage mode control input. By connecting Pin 11 to Ground, the MC44603 can be shut down.
12	RP Standby	A voltage level applied to the RP Standby pin determines the output power level at which the oscillator will turn into the reduced frequency mode of operation (i.e. standby mode). An internal hysteresis comparator allows to return in the normal mode at a higher output power level.
13	E/A Out	The error amplifier output is made available for loop compensation.
14	Voltage Feedback	This is the inverting input of the Error Amplifier. It can be connected to the switching power supply output through an optical (or other) feedback loop.
15	R_F Standby	The reduced frequency or standby frequency programming is made by the R_F Standby resistance choice.
16	R_{ref}	R_{ref} sets the internal reference current. The internal reference current ranges from 100 μA to 500 μA . This requires that $5.0\ k\Omega \leq R_{ref} \leq 25\ k\Omega$.

Figure 27. Starting Behavior and Overvoltage Management

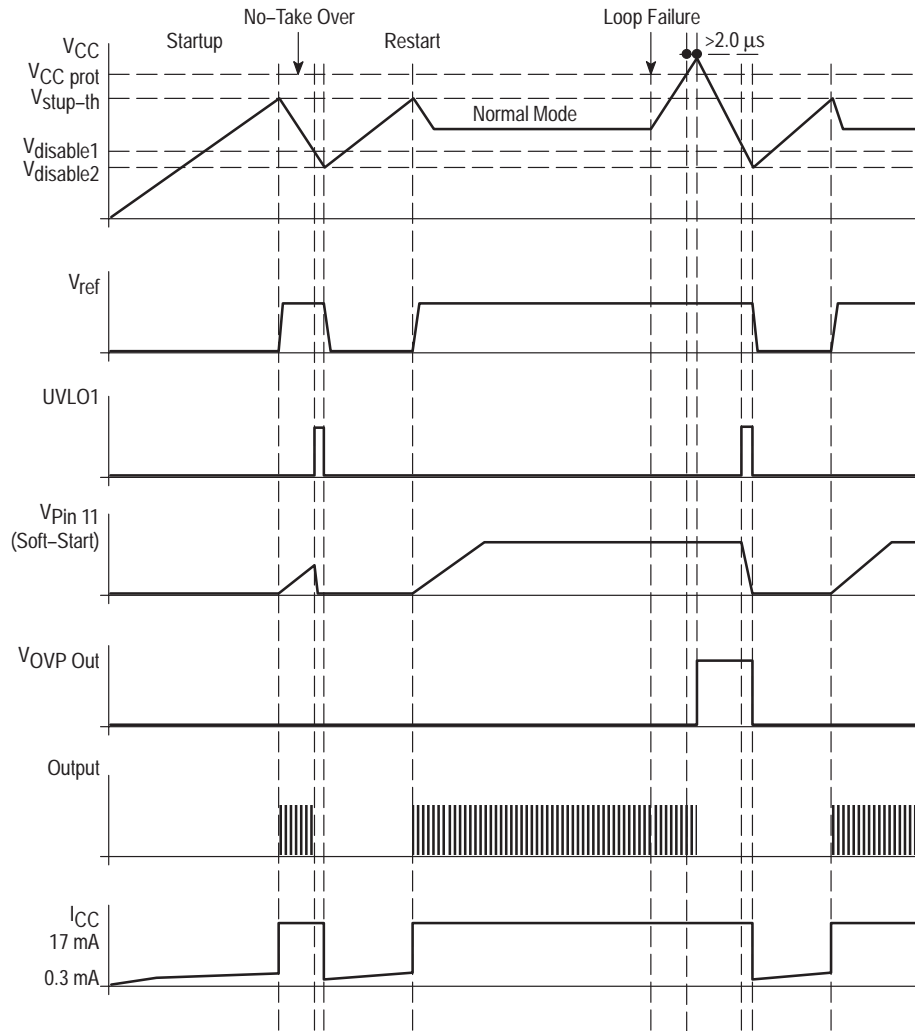

Figure 28. Demagnetization

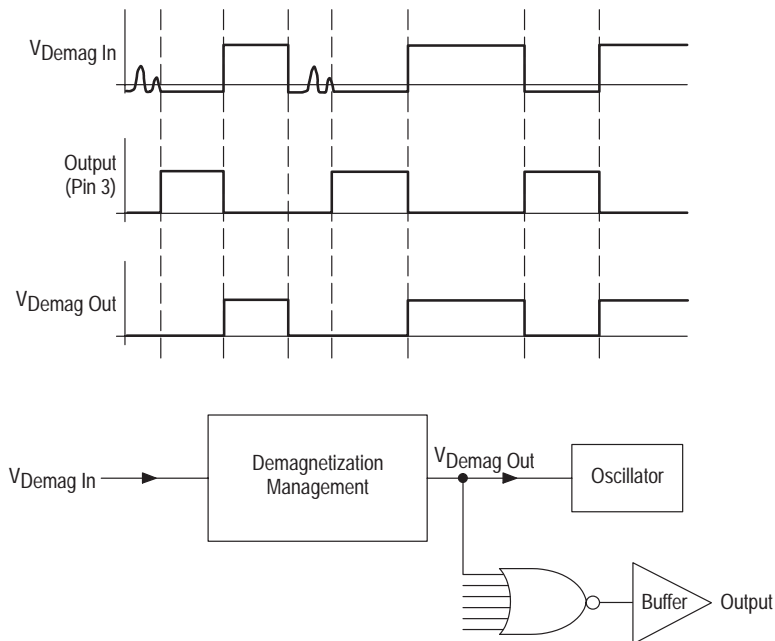

Figure 29. Switching Off Behavior

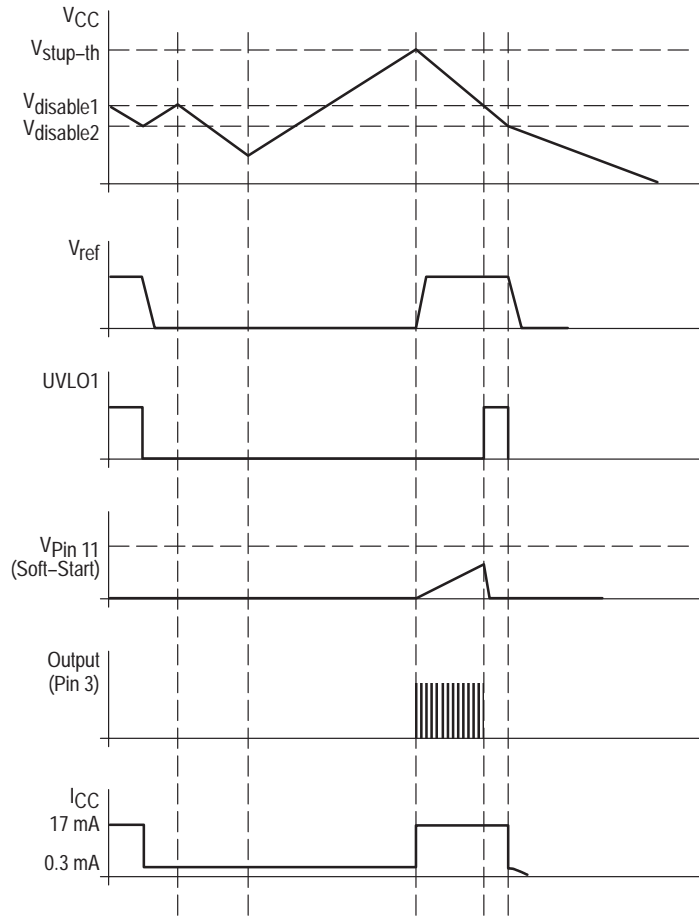

Figure 30. Oscillator

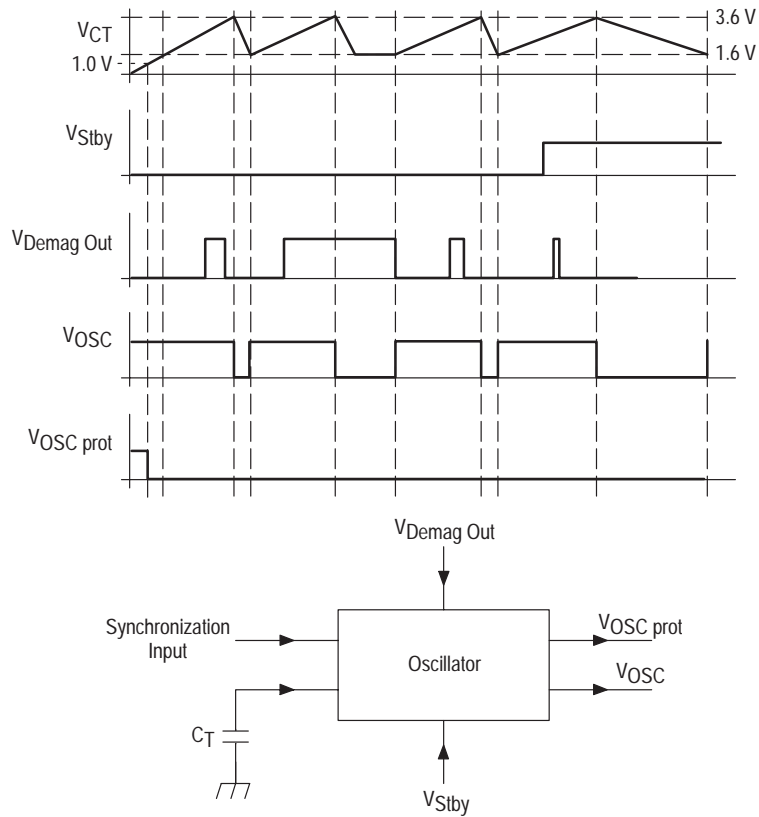
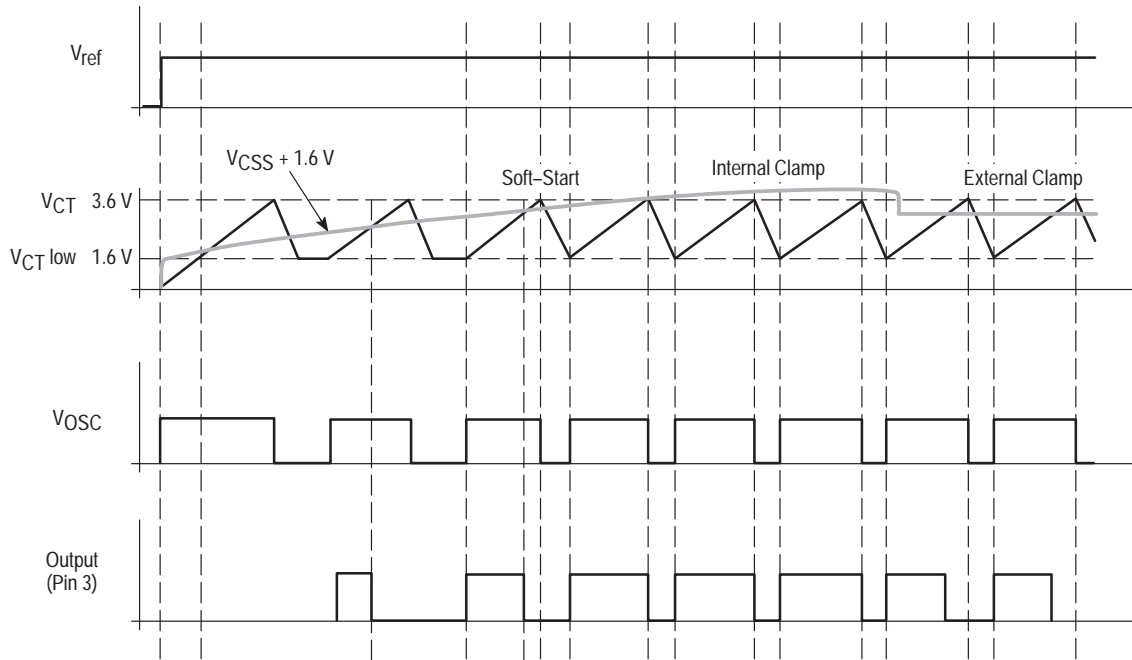

Figure 31. Soft-Start & D_{max}



OPERATING DESCRIPTION

Error Amplifier

A fully compensated Error Amplifier with access to the inverting input and output is provided. It features a typical dc voltage gain of 70 dB. The noninverting input is internally biased at 2.5 V and is not pinned out. The converter output voltage is typically divided down and monitored by the inverting input. The maximum input bias current with the inverting input at 2.5 V is $-2.0 \mu\text{A}$. This can cause an output voltage error that is equal to the product of the input bias current and the equivalent input divider source resistance.

The Error Amp output (Pin 13) is provided for external loop compensation. The output voltage is offset by two diode drops ($\approx 1.4 \text{ V}$) and divided by three before it connects to the inverting input of the Current Sense Comparator. This guarantees that no drive pulses appear at the Output (Pin 3) when Pin 13 is at its lowest state (V_{OL}). The Error Amp minimum feedback resistance is limited by the amplifier's minimum source current (0.2 mA) and the required output voltage (V_{OH}) to reach the current sense comparator's 1.0 V clamp level:

$$R_{f(\text{min})} \approx \frac{3.0 (1.0 \text{ V}) + 1.4 \text{ V}}{0.2 \text{ mA}} = 22 \text{ k}\Omega$$

Figure 32. Error Amplifier Compensation

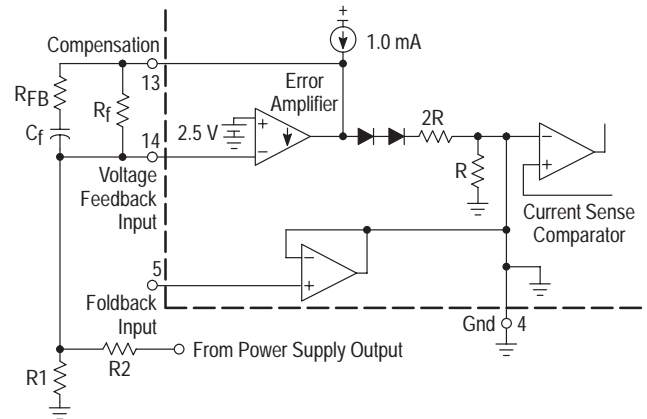

Current Sense Comparator and PWM Latch

The MC44603 can operate as a current mode controller or as a voltage mode controller. In current mode operation, the MC44603 uses the current sense comparator. The output switch conduction is initiated by the oscillator and terminated when the peak inductor current reaches the threshold level

established by the Error Amplifier output (Pin 13). Thus, the error signal controls the peak inductor current on a cycle-by-cycle basis. The Current Sense Comparator PWM Latch ensures that only a single pulse appears at the Source Output during the appropriate oscillator cycle.

The inductor current is converted to a voltage by inserting the ground referenced sense resistor R_S in series with the power switch Q1.

This voltage is monitored by the Current Sense Input (Pin 7) and compared to a level derived from the Error Amp output. The peak inductor current under normal operating conditions is controlled by the voltage at Pin 13 where:

$$I_{pk} \approx \frac{V(\text{Pin 13}) - 1.4 \text{ V}}{3 R_S}$$

The Current Sense Comparator threshold is internally clamped to 1.0 V. Therefore, the maximum peak switch current is:

$$I_{pk(\text{max})} \approx \frac{1.0 \text{ V}}{R_S}$$

Figure 33. Output Totem Pole

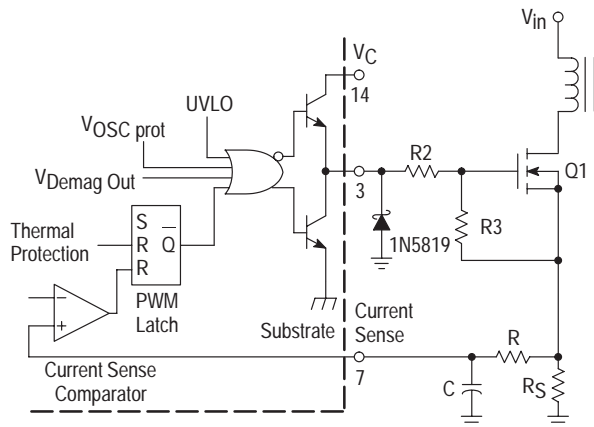

Oscillator

The oscillator is a very accurate sawtooth generator that can work either in free mode or in synchronization mode. In this second mode, the oscillator stops in the low state and waits for a demagnetization or a synchronization pulse to start a new charging cycle.

• **The Sawtooth Generation:**

In the steady state, the oscillator voltage varies between about 1.6 V and 3.6 V.

The sawtooth is obtained by charging and discharging an external capacitor C_T (Pin 10), using two distinct current sources = I_{charge} and $I_{\text{discharge}}$. In fact, C_T is permanently connected to the charging current source ($0.4 I_{\text{ref}}$) and so, the discharge current source has to be higher than the charge current to be able to decrease the C_T voltage (refer to Figure 35).

This condition is performed, its value being ($2.0 I_{\text{ref}}$) in normal working and ($0.4 I_{\text{ref}} + 0.5 I_{\text{F Stby}}$) in standby mode).

Figure 34. Oscillator

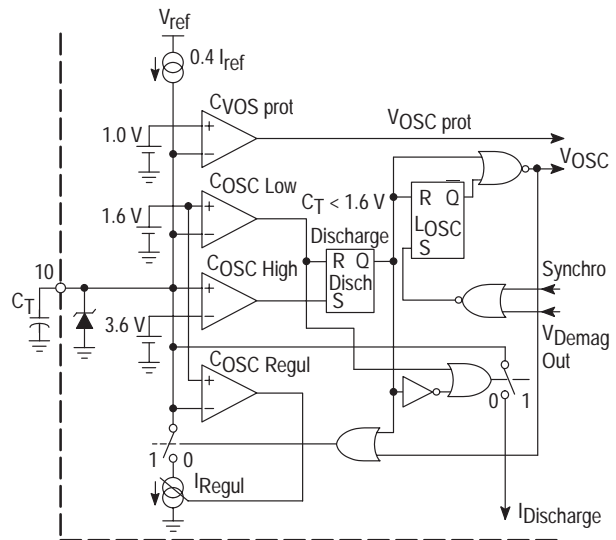
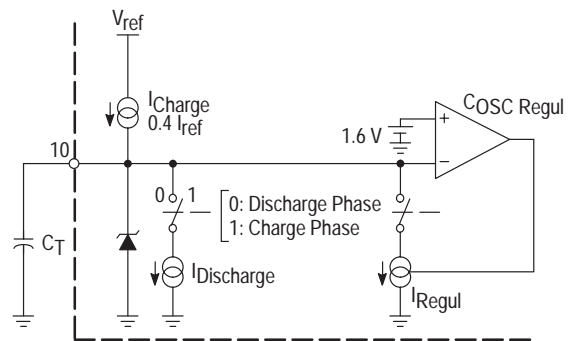

Figure 35. Simplified Block Oscillator



Two comparators are used to generate the sawtooth. They compare the C_T voltage to the oscillator valley (1.6 V) and peak reference (3.6 V) values. A latch (L_{disch}) memorizes the oscillator state.

In addition to the charge and discharge cycles, a third state can exist. This phase can be produced when, at the end of the discharge phase, the oscillator has to wait for a synchronization or demagnetization pulse before restarting. During this delay, the C_T voltage must remain equal to the oscillator valley value ($\approx 1.6 \text{ V}$). So, a third regulated current source I_{Regul} controlled by $C_{\text{OSC Regul}}$, is connected to C_T in order to perfectly compensate the ($0.4 I_{\text{ref}}$) current source that permanently supplies C_T .

The maximum duty cycle is 80%. Indeed, the on-time is allowed only during the oscillator capacitor charge.

Consequently:

$$T_{\text{charge}} = C_T \times \Delta V / I_{\text{charge}}$$

$$T_{\text{discharge}} = C_T \times \Delta V / I_{\text{discharge}}$$

where:

T_{charge} is the oscillator charge time
 ΔV is the oscillator peak-to-peak value
 I_{charge} is the oscillator charge current

and

$T_{\text{discharge}}$ is the oscillator discharge time
 $I_{\text{discharge}}$ is the oscillator discharge current

So, as $f_S = 1 / (T_{charge} + T_{discharge})$ when the Regul arrangement is not activated, the operating frequency can be obtained from the graph in Figure 1.

NOTE: The output is disabled by the signal $V_{OSC prot}$ when V_{CT} is lower than 1.0 V (refer to Figure 30).

Synchronization and Demagnetization Blocks

To enable the output, the L_{OSC} latch complementary output must be low. Reset is activated by the L_{disch} output during the discharge phase. To restart, the L_{OSC} has to be set (refer to Figure 34). To perform this, the demagnetization signal and the synchronization must be low.

• **Synchronization:**

The synchronization block consists of two comparators that compare the synchronization signal (external) to 0.7 and 3.7 V (typical values). The comparators' outputs are connected to the input of an AND gate so that the final output of the block should be :

- high when $0.7 < SYNC < 3.7$ V
- low in the other cases.

As a low level is necessary to enable the output, synchronized low level pulses have to be generated on the output of the synchronization block. If synchronization is not required, the Pin 9 must be connected to the ground.

Figure 36. Synchronization

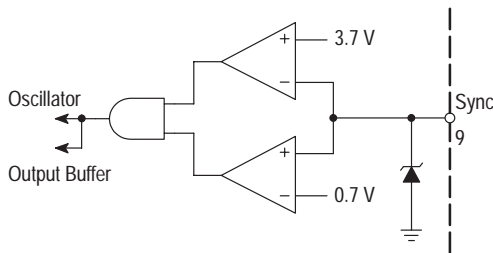

• **Demagnetization:**

In flyback applications, a good means to detect magnetic saturation of the transformer core, or demagnetization, consists in using the auxiliary winding voltage. This voltage is:

- negative during the on-time,
- positive during the off-time,
- equal to zero for the dead-time with generally some ringing (refer to Figure 37).

That is why, the MC44603 demagnetization detection consists of a comparator that can compare the auxiliary winding voltage to a reference that is typically equal to 65 mV.

Figure 37. Demagnetization Detection

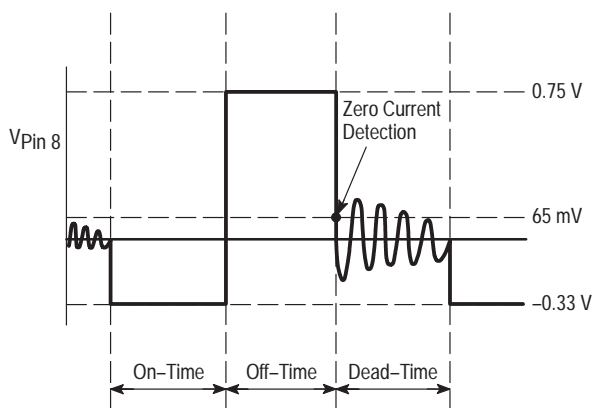

A diode D has been incorporated to clamp the positive applied voltages while an active clamping system limits the negative voltages to typically -0.33 V. This negative clamp level is sufficient to avoid the substrate diode switching on.

In addition to the comparator, a latch system has been incorporated in order to keep the demagnetization block output level low as soon as a voltage lower than 65 mV is detected and as long as a new restart is produced (high level on the output) (refer to Figure 38). This process prevents ringing on the signal at Pin 8 from disrupting the demagnetization detection. This results in a very accurate demagnetization detection.

The demagnetization block output is also directly connected to the output, disabling it during the demagnetization phase (refer to Figure 33).

NOTE: The demagnetization detection can be inhibited by connecting Pin 8 to the ground.

Figure 38. Demagnetization Block

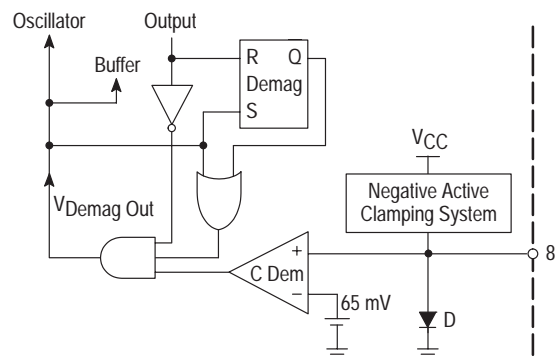

Standby

• **Power Losses in a Classical Flyback Structure**

Figure 39. Power Losses in a Classical Flyback Structure

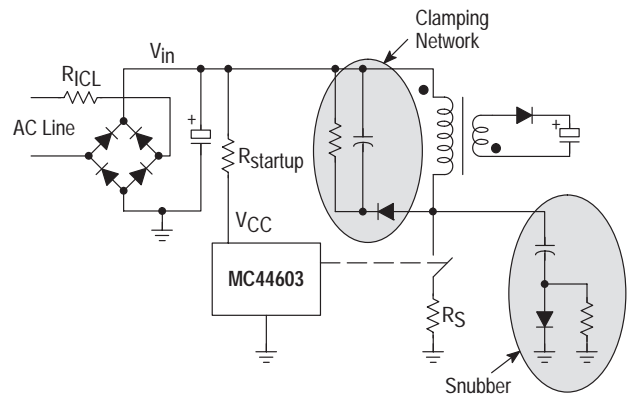

In a classical flyback (as depicted in Figure 39), the standby losses mainly consist of the energy waste due to:

- the startup resistor $R_{startup}$ → $P_{startup}$
- the consumption of the IC and the power switch control → $P_{control}$
- the inrush current limitation resistor R_{IJCL} → P_{IJCL}
- the switching losses in the power switch → P_{SW}
- the snubber and clamping network → P_{SN-CLN}

$P_{startup}$ is nearly constant and is equal to:

$$((V_{in}-V_{CC})^2/R_{startup})$$

P_{ICL} only depends on the current drawn from the mains. Losses can be considered constant. This waste of energy decreases when the standby losses are reduced.

$P_{control}$ increases when the oscillator frequency is increased (each switching requires some energy to turn on the power switch).

PSW and $PSN-CLN$ are proportional to the switching frequency.

Consequently, standby losses can be minimized by decreasing the switching frequency as much as possible.

The MC44603 was designed to operate at a standby frequency lower than the normal working one.

• **Standby Power Calculations with MC44603**

During a switching period, the energy drawn by the transformer during the on-time to be transferred to the output during the off-time, is equal to:

$$E = \frac{1}{2} \times L \times I_{pk}^2$$

where:

- L is the transformer primary inductor,
- I_{pk} is the inductor peak current.

Input power is labelled P_{in} :

$$P_{in} = 0.5 \times L \times I_{pk}^2 \times f_S$$

where f_S is the normal working switching frequency.

Also,

$$I_{pk} = \frac{V_{CS}}{R_S}$$

where R_S is the resistor used to measure the power switch current.

Thus, the input power is proportional to V_{CS}^2 (V_{CS} being the internal current sense comparator input).

That is why the standby detection is performed by creating a V_{CS} threshold. An internal current source ($0.4 \times I_{ref}$) sets the threshold level by connecting a resistor to Pin 12.

As depicted in Figure 40, the standby comparator noninverting input voltage is typically equal to $(3.0 \times V_{CS} + V_F)$ while the inverter input value is $(V_{R P Stby} + V_F)$.

Figure 40. Standby

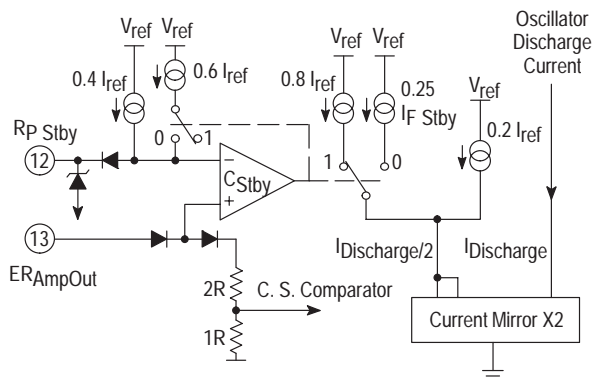

The V_{CS} threshold level is typically equal to $[(V_{R P Stby})/3]$ and if the corresponding power threshold is labelled P_{thL} :

$$P_{thL} = 0.5 \times L \times \left(\frac{V_{R P Stby}}{3.0 R_S} \right)^2 \times f_S$$

And as:

$$\begin{aligned} V_{R P Stby} &= R_{P Stby} \times 0.4 \times I_{ref} \\ &= R_{R P Stby} \times 0.4 \times \frac{V_{ref}}{R_{ref}} \end{aligned}$$

$$R_{P Stby} = \frac{10.6 \times R_S \times R_{ref}}{V_{ref}} \times \sqrt{\frac{P_{thL}}{L \times f_S}}$$

Thus, when the power drawn by the converter decreases, V_{CS} decreases and when V_{CS} becomes lower than $[V_{CS-th} \times (V_{R P Stby})/3]$, the standby mode is activated. This results in an oscillator discharge current reduction in order to increase the oscillator period and to diminish the switching frequency. As it is represented in Figure 40, the $(0.8 \times I_{ref})$ current source is disconnected and is replaced by a lower value one ($0.25 \times I_{F Stby}$).

Where: $I_{F Stby} = V_{ref}/R_{F Stby}$

In order to prevent undesired mode switching when power is close to the threshold value, a hysteresis that is proportional to $V_{R P Stby}$ is incorporated creating a second V_{CS} threshold level that is equal to $[2.5 \times (V_{R P Stby})/3]$. When the standby comparator output is high, a second current source ($0.6 \times I_{ref}$) is connected to Pin 12.

Finally, the standby mode function can be shown graphically in Figure 41.

Figure 41. Dynamic Mode Change

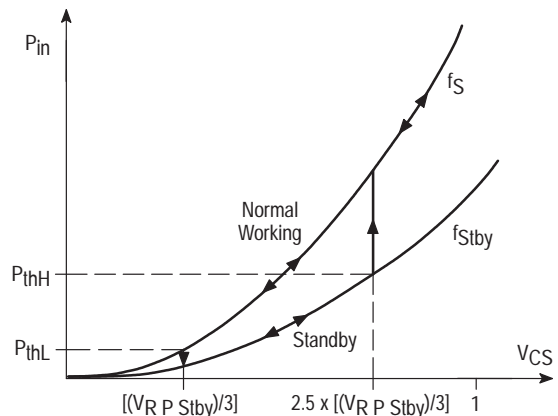

This curve shows that there are two power threshold levels:

- the low one:

$$P_{thL} \text{ fixed by } V_{R P Stby}$$

- the high one:

$$P_{thH} = (2.5)^2 \times P_{thL} \times \frac{f_{Stby}}{f_S}$$

$$P_{thH} = 6.25 \times P_{thL} \times \frac{f_{Stby}}{f_S}$$

Maximum Duty Cycle and Soft-Start Control

Maximum duty cycle can be limited to values less than 80% by utilizing the D_{max} and soft-start control. As depicted in Figure 42, the Pin 11 voltage is compared to the oscillator sawtooth.

Figure 42. D_{max} and Soft-Start

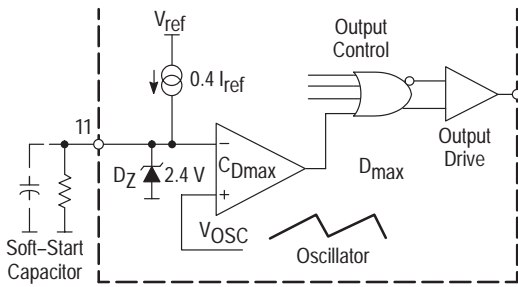
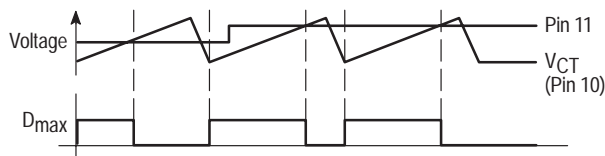

Figure 43. Maximum Duty Cycle Control



Using the internal current source ($0.4 I_{ref}$), the Pin 11 voltage can easily be set by connecting a resistor to this pin.

If a capacitor is connected to Pin 11, the voltage increases from 0 to its maximum value progressively (refer to Figure 44), thereby, implementing a soft-start. The soft-start capacitor is discharged internally when the V_{CC} (Pin 1) voltage drops below 9.0 V.

Figure 44. Different Possible Uses of Pin 11

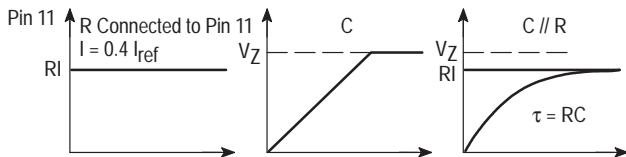

If no external component is connected to Pin 11, an internal zener diode clamps the Pin 11 voltage to a value V_Z that is higher than the oscillator peak value, disabling soft-start and maximum duty cycle limitation.

Foldback

As depicted in Figure 32, the foldback input (Pin 5) can be used to reduce the maximum V_{CS} value, providing foldback protection. The foldback arrangement is a programmable peak current limitation.

If the output load is increased, the required converter peak current becomes higher and V_{CS} increases until it reaches its maximum value (normally, $V_{CS\ max} = 1.0\ V$).

Then, if the output load keeps on increasing, the system is unable to supply enough energy to maintain the output voltages in regulation. Consequently, the decreasing output can be applied to Pin 5, in order to limit the maximum peak current. In this way, the well known foldback characteristic can be obtained (refer to Figure 45).

Figure 45. Foldback Characteristic

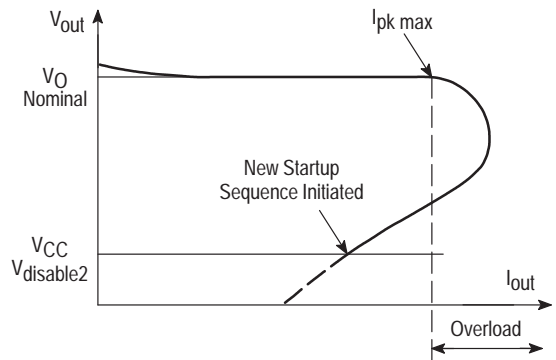

NOTE: Foldback is disabled by connecting Pin 5 to V_{CC} .

Overvoltage Protection

The overvoltage arrangement consists of a comparator that compares the Pin 6 voltage to V_{ref} (2.5 V) (refer to Figure 46).

If no external component is connected to Pin 6, the comparator noninverting input voltage is nearly equal to:

$$\left(\frac{2.0\ k\Omega}{11.6\ k\Omega + 2.0\ k\Omega} \right) \times V_{CC}$$

The comparator output is high when:

$$\left(\frac{2.0\ k\Omega}{11.6\ k\Omega + 2.0\ k\Omega} \right) \times V_{CC} \geq 2.5\ V$$

$$\Leftrightarrow V_{CC} \geq 17\ V$$

A delay latch (2.0 μs) is incorporated in order to sense overvoltages that last at least 2.0 μs .

If this condition is achieved, $V_{OVP\ out}$, the delay latch output, becomes high. As this level is brought back to the input through an OR gate, $V_{OVP\ out}$ remains high (disabling the IC output) until V_{ref} is disabled.

Consequently, when an overvoltage longer than 2.0 μs is detected, the output is disabled until V_{CC} is removed and then re-applied.

The V_{CC} is connected after V_{ref} has reached steady state in order to limit the circuit startup consumption.

The overvoltage section is enabled 5.0 μs after the regulator has started to allow the reference V_{ref} to stabilize.

By connecting an external resistor to Pin 6, the threshold V_{CC} level can be changed.

Figure 46. Overvoltage Protection

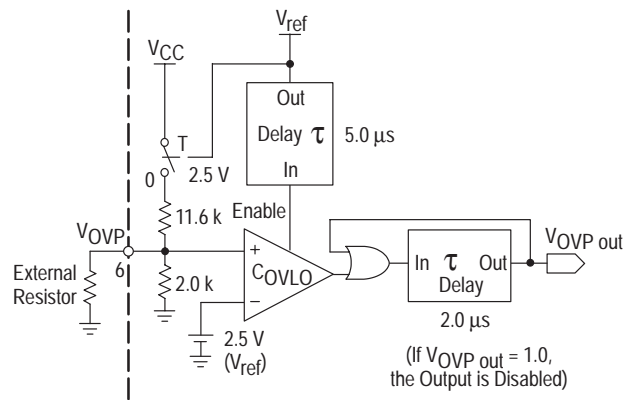

Undervoltage Lockout Section

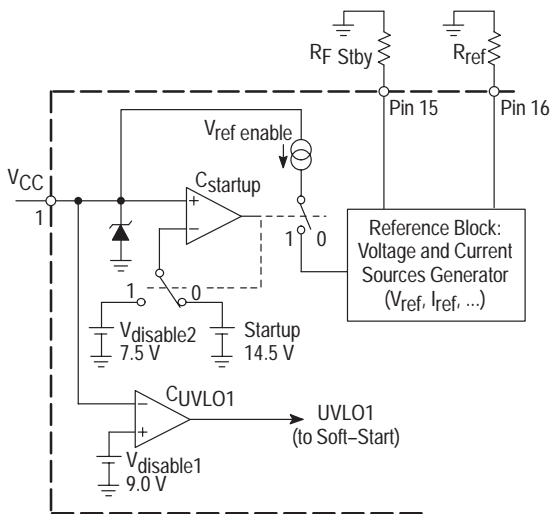
Figure 47. V_{CC} Management

As depicted in Figure 47, an undervoltage lockout has been incorporated to guarantee that the IC is fully functional before allowing system operation.

This block particularly, produces V_{ref} (Pin 16 voltage) and I_{ref} that is determined by the resistor R_{ref} connected between Pin 16 and the ground:

$$I_{ref} = \frac{V_{ref}}{R_{ref}} \text{ where } V_{ref} = 2.5 \text{ V (typically)}$$

Another resistor is connected to the Reference Block: $R_{F \text{ Stby}}$ that is used to fix the standby frequency.

In addition to this, V_{CC} is compared to a second threshold level that is nearly equal to 9.0 V ($V_{disable1}$). $UVLO1$ is generated to reset the maximum duty cycle and soft-start block disabling the output stage as soon as V_{CC} becomes lower than $V_{disable1}$. In this way, the circuit is reset and made ready for the next startup, before the reference block is disabled (refer to Figure 29). Finally, the upper limit for the minimum normal operating voltage is 9.4 V (maximum value of $V_{disable1}$) and so the minimum hysteresis is 4.2 V. ($(V_{stap-th})_{min} = 13.6 \text{ V}$).

The large hysteresis and the low startup current of the MC44603 make it ideally suited for off-line converter applications where efficient bootstrap startup techniques are required.

Figure 48. 250 W Input Power Off-Line Flyback Converter with MOSFET Switch

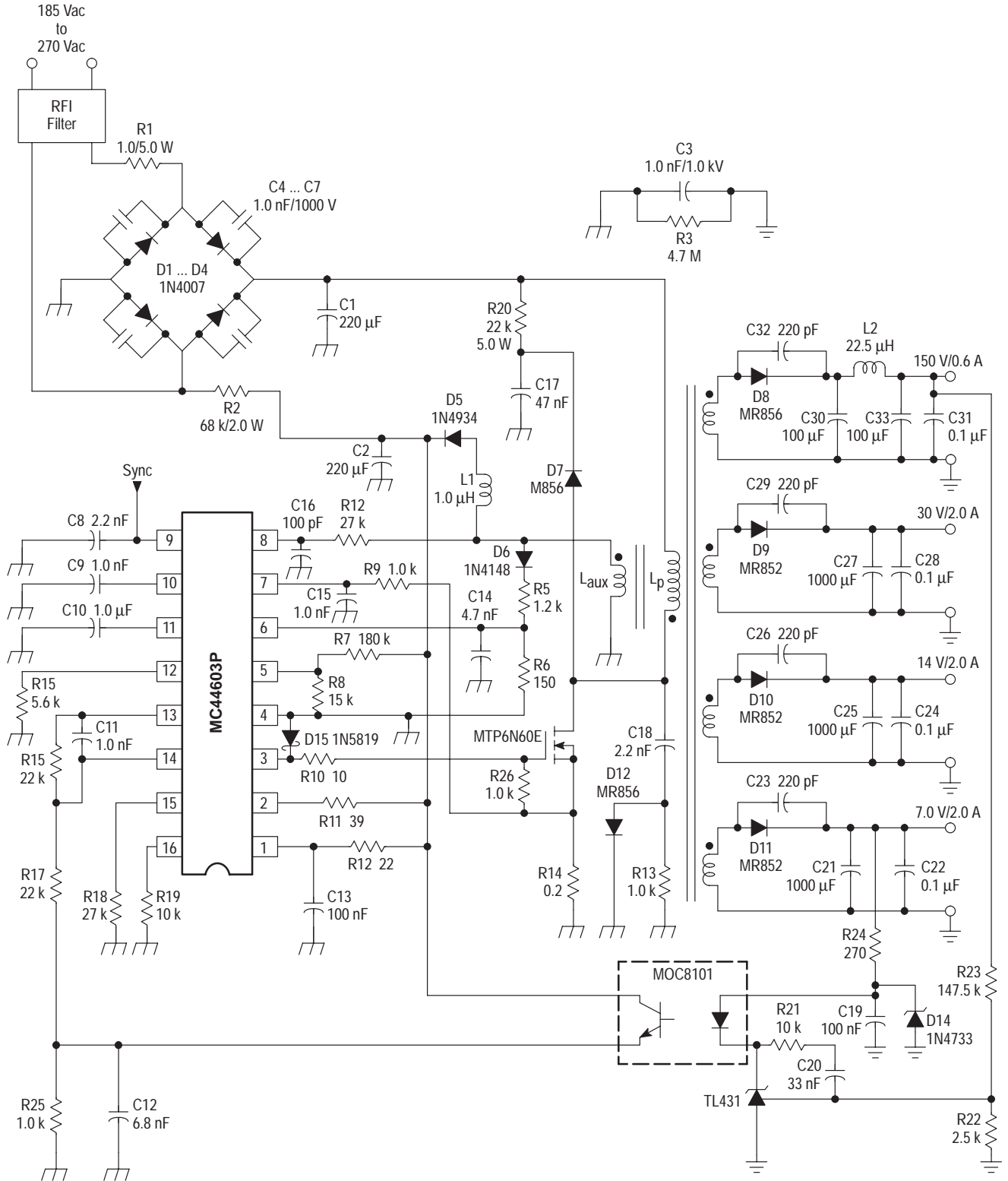

MC44603

250 W Input Power Fly-Back Converter 185 V – 270 V Mains Range MC44603P & MTP6N60E

Tests	Conditions	Results
Line Regulation 150 V 30 V 14 V 7.0 V	$V_{in} = 185 \text{ Vac to } 270 \text{ Vac}$ $F_{mains} = 50 \text{ Hz}$ $I_{out} = 0.6 \text{ A}$ $I_{out} = 2.0 \text{ A}$ $I_{out} = 2.0 \text{ A}$ $I_{out} = 2.0 \text{ A}$	10 mV 10 mV 10 mV 20 mV
Load Regulation 150 V	$V_{in} = 220 \text{ Vac}$ $I_{out} = 0.3 \text{ A to } 0.6 \text{ A}$	50 mV
Cross Regulation 150 V	$V_{in} = 220 \text{ Vac}$ $I_{out} (150 \text{ V}) = 0.6 \text{ A}$ $I_{out} (30 \text{ V}) = 0 \text{ A to } 2.0 \text{ A}$ $I_{out} (14 \text{ V}) = 2.0 \text{ A}$ $I_{out} (7.0 \text{ V}) = 2.0 \text{ A}$	< 1.0 mV
Efficiency	$V_{in} = 220 \text{ Vac}, P_{in} = 250 \text{ W}$	81%
Standby Mode P input	$V_{in} = 220 \text{ Vac}, P_{out} = 0 \text{ W}$	3.3 W
Switching Frequency		20 kHz fully stable
Output Short Circuit	$P_{out} (\text{max}) = 270 \text{ W}$	Safe on all outputs
Startup	$P_{in} = 250 \text{ W}$	$V_{ac} = 160 \text{ V}$

MC44603

Figure 49. 125 W Input Power Off-Line Flyback Converter with Bipolar Switch

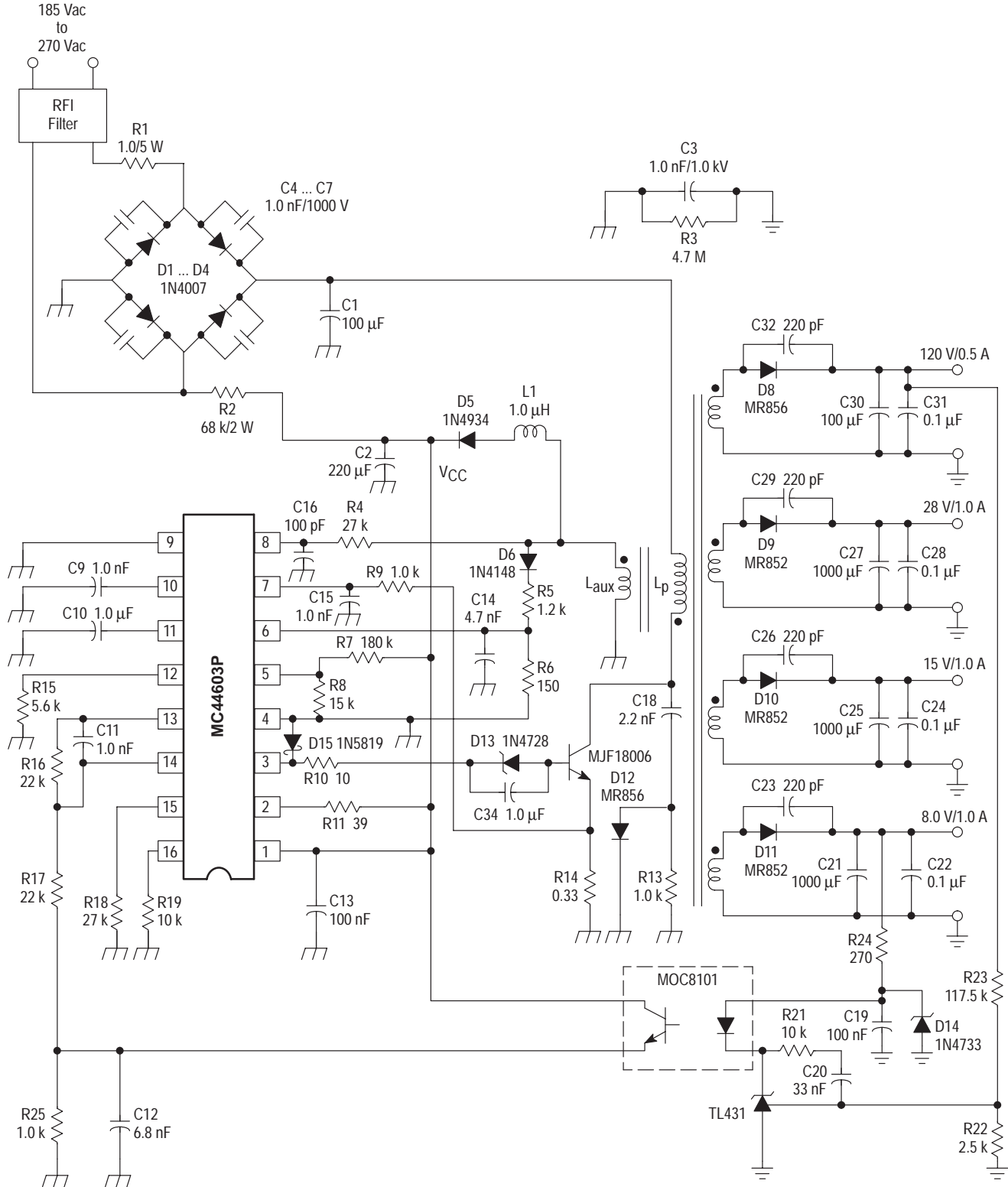

MC44603

125 W Input Power Fly-Back Converter 185 V – 270 V Mains Range MC44603P & MJF18006

Tests	Conditions	Results
Line Regulation 120 V 28 V 15 V 8.0 V	$V_{in} = 185 \text{ Vac to } 270 \text{ Vac}$ $F_{mains} = 60 \text{ Hz}$ $I_{out} = 0.5 \text{ A}$ $I_{out} = 1.0 \text{ A}$ $I_{out} = 1.0 \text{ A}$ $I_{out} = 1.0 \text{ A}$	10 mV 10 mV 10 mV 20 mV
Load Regulation 120 V	$V_{in} = 220 \text{ Vac}$ $I_{out} = 0.2 \text{ A to } 0.5 \text{ A}$	= 0.05 V
Cross Regulation 120 V	$V_{in} = 220 \text{ Vac}$ $I_{out} (120 \text{ V}) = 0.5 \text{ A}$ $I_{out} (28 \text{ V}) = 0 \text{ A to } 1.0 \text{ A}$ $I_{out} (15 \text{ V}) = 1.0 \text{ A}$ $I_{out} (8.0 \text{ V}) = 1.0 \text{ A}$	< 1.0 mV
Efficiency	$V_{in} = 220 \text{ Vac}, P_{in} = 125 \text{ W}$	85%
Standby Mode P input	$V_{in} = 220 \text{ Vac}, P_{out} = 0 \text{ W}$	2.46 W
Switching Frequency		20 kHz fully stable
Output Short Circuit	$P_{out} (\text{max}) = 140 \text{ W}$	Safe on all outputs
Startup	$P_{in} = 125 \text{ W}$	$V_{ac} = 150 \text{ V}$

Tape and Reel Options

In Brief . . .

Motorola offers the convenience of Tape and Reel packaging for our growing family of standard integrated circuit products. Reels are available to support the requirements of both first and second generation pick-and-place equipment. The packaging fully conforms to the latest EIA-481A specification. The antistatic embossed tape provides a secure cavity, sealed with a peel-back cover tape.

	Page
Tape and Reel Configurations	12-2
Tape and Reel Information Table	12-4
Analog MPQ Table	12-5

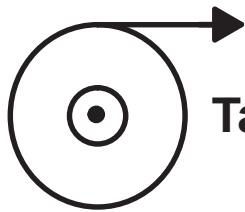

Tape and Reel Configurations

Mechanical Polarization

SOIC and Micro-8 DEVICES

Typical

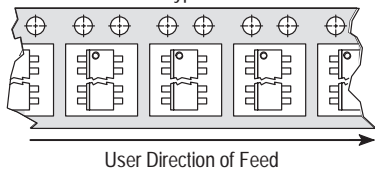

PLCC DEVICES

Typical

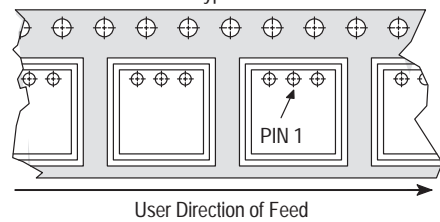

DPAK and D²PAK DEVICES

Typical

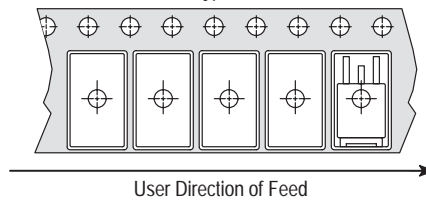

SOT-23 (5 Pin) DEVICES

Typical

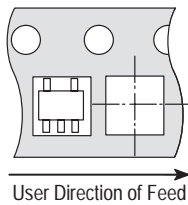

SOT-89 (3 Pin) DEVICES

Typical

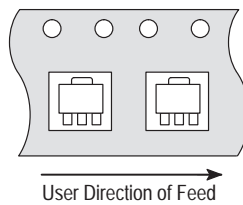

SOT-89 (5 Pin) DEVICES

Typical

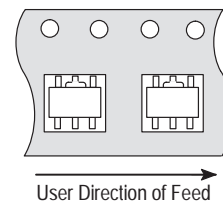

Tape and Reel Configurations (continued)

TO-92 Reel Styles

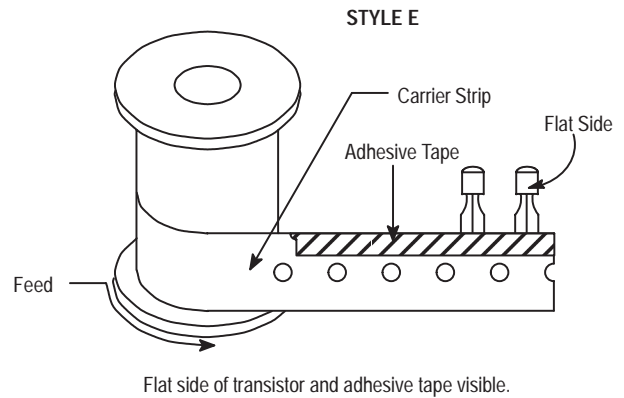
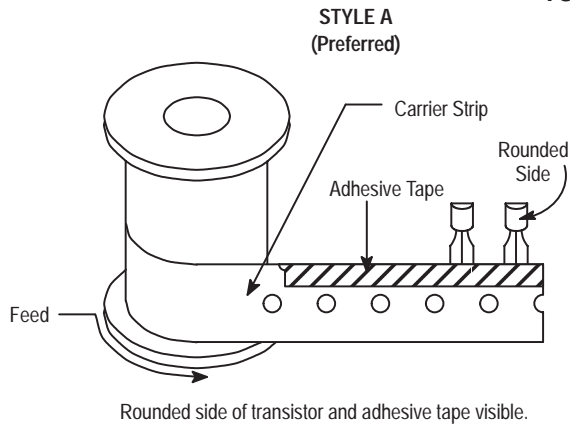

TO-92 Ammo Pack Styles

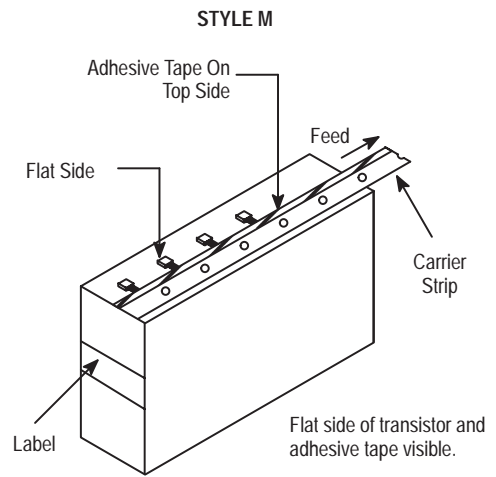
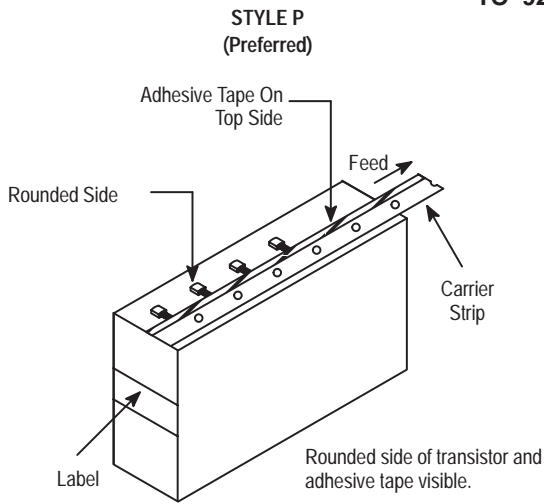

Style P ammo pack is equivalent to Styles A and B of reel pack dependent on feed orientation from box.

Style M ammo pack is equivalent to Style E of reel pack dependent on feed orientation from box.

TO-92 EIA Radial Tape in Fan Fold Box or On Reel

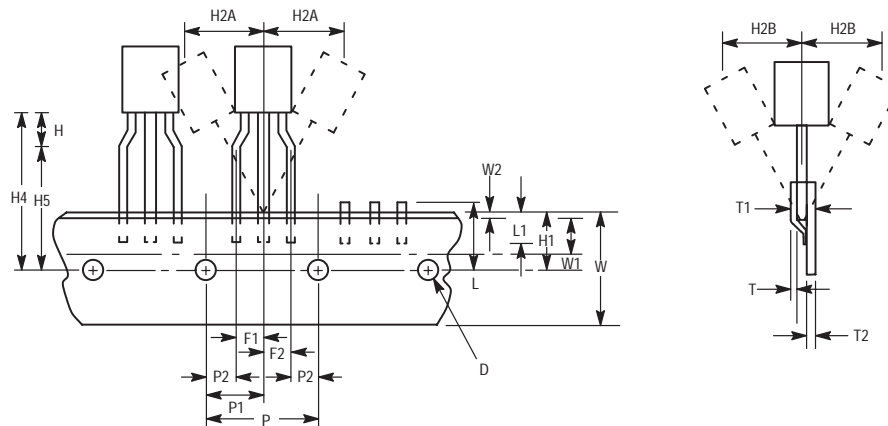

Tape and Reel Information Table

Package	Tape Width (mm)	Devices ⁽¹⁾ per Reel	Reel Size (inch)	Device Suffix
SO-8, SOP-8	12	2,500	13	R2
SO-14	16	2,500	13	R2
SO-16	16	2,500	13	R2
SO-16L, SO-8+8L WIDE	16	1,000	13	R2
SO-20L WIDE	24	1,000	13	R2
SO-24L WIDE	24	1,000	13	R2
SO-28L WIDE	24	1,000	13	R2
SO-28L WIDE	32	1,000	13	R3
Micro-8	12	2,500	13	R2
PLCC-20	16	1,000	13	R2
PLCC-28	24	500	13	R2
PLCC-44	32	500	13	R2
PLCC-52	32	500	13	R2
PLCC-68	44	250	13	R2
PLCC-84	44	250	13	R2
TO-226AA (TO-92) ⁽²⁾	18	2,000	13	RA, RE, RP, or RM (Ammo Pack) only
DPAK	16	2,500	13	RK
D ² PAK	24	800	13	R4
SOT-23 (5 Pin)	8	3,000	7	TR
SOT-89 (3/5 Pin)	12	1,000	7	T1

⁽¹⁾ Minimum order quantity is 1 reel. Distributors/OEM customers may break lots or reels at their option, however broken reels may not be returned.

⁽²⁾ Integrated circuits in TO-226AA packages are available in Styes A and E only, with optional "Ammo Pack" (Suffix RP or RM). The RA and RP configurations are preferred. For ordering information please contact your local Motorola Semiconductor Sales Office.

Analog MPQ Table

Tape/Reel and Ammo Pack

Package Type	Package Code	MPQ
PLCC		
Case 775	0802	1000/reel
Case 776	0804	500/reel
Case 777	0801	500/reel
SOIC		
Case 751	0095	2500/reel
Case 751A	0096	2500/reel
Case 751B	0097	2500/reel
Case 751G	2003	1000/reel
Case 751D	2005	1000/reel
Case 751E	2008	1000/reel
Case 751F	2009	1000/reel
Micro-8		
Case 846A	-	2500/reel
TO-92		
Case 29	0031	2000/reel
Case 29	0031	2000/Ammo Pack
DPAK		
Case 369A	-	2500/reel
D2PAK		
Case 936	-	800/reel
SOT-23 (5 Pin)		
Case 1212	-	3000/reel
SOT-89 (3 Pin)		
Case 1213	-	1000/reel
SOT-89 (5 Pin)		
Case 1214	-	1000/reel

Packaging Information

In Brief . . .

The packaging availability for each device type is indicated on the individual data sheets and the Selector Guide. All of the outline dimensions for the packages are given in this section.

The maximum power consumption an integrated circuit can tolerate at a given operating ambient temperature can be found from the equation:

$$P_{D(TA)} = \frac{T_{J(max)} - T_A}{R_{\theta JA(Typ)}}$$

where:

$P_{D(TA)}$ = *Power Dissipation allowable at a given operating ambient temperature. This must be greater than the sum of the products of the supply voltages and supply currents at the worst case operating condition.*

$T_{J(max)}$ = *Maximum operating Junction Temperature as listed in the Maximum Ratings Section. See individual data sheets for $T_{J(max)}$ information.*

T_A = *Maximum desired operating Ambient Temperature*

$R_{\theta JA(Typ)}$ = *Typical Thermal Resistance Junction-to-Ambient*

Case Outline Dimensions

LP, P, Z SUFFIX
CASE 29-04
 Plastic Package
 (TO-226AA/TO-92)
 ISSUE AD

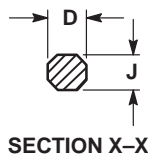
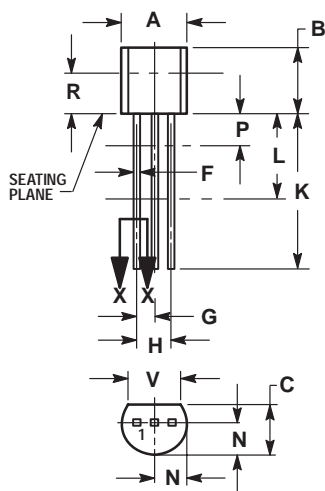
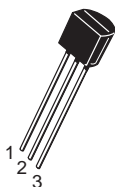

- NOTES:
1. DIMENSIONING AND TOLERANCING PER ANSI Y14.5M, 1982.
 2. CONTROLLING DIMENSION: INCH.
 3. CONTOUR OF PACKAGE BEYOND DIMENSION R IS UNCONTROLLED.
 4. DIMENSION F APPLIES BETWEEN P AND L. DIMENSION D AND J APPLY BETWEEN L AND K MINIMUM. LEAD DIMENSION IS UNCONTROLLED IN P AND BEYOND DIMENSION K MINIMUM.

DIM	INCHES		MILLIMETERS	
	MIN	MAX	MIN	MAX
A	0.175	0.205	4.45	5.20
B	0.170	0.210	4.32	5.33
C	0.125	0.165	3.18	4.19
D	0.016	0.022	0.41	0.55
F	0.016	0.019	0.41	0.48
G	0.045	0.055	1.15	1.39
H	0.095	0.105	2.42	2.66
J	0.015	0.020	0.39	0.50
K	0.500	---	12.70	---
L	0.250	---	6.35	---
N	0.080	0.105	2.04	2.66
P	---	0.100	---	2.54
R	0.115	---	2.93	---
V	0.135	---	3.43	---

KC, T SUFFIX
CASE 221A-06
 Plastic Package
 ISSUE Y

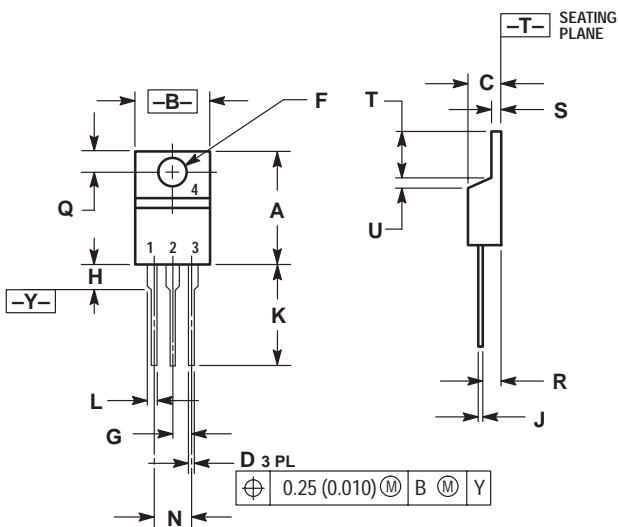
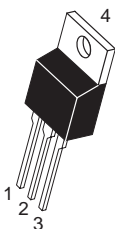

- NOTES:
1. DIMENSIONING AND TOLERANCING PER ANSI Y14.5M, 1982.
 2. CONTROLLING DIMENSION: INCH.

DIM	INCHES		MILLIMETERS	
	MIN	MAX	MIN	MAX
A	0.560	0.625	14.23	15.87
B	0.380	0.420	9.66	10.66
C	0.140	0.190	3.56	4.82
D	0.020	0.045	0.51	1.14
F	0.139	0.155	3.53	3.93
G	0.100 BSC	---	2.54 BSC	---
H	---	0.280	---	7.11
J	0.012	0.045	0.31	1.14
K	0.500	0.580	12.70	14.73
L	0.045	0.070	1.15	1.77
N	0.200 BSC	---	5.08 BSC	---
Q	0.100	0.135	2.54	3.42
R	0.080	0.115	2.04	2.92
S	0.020	0.055	0.51	1.39
T	0.235	0.255	5.97	6.47
U	0.000	0.050	0.00	1.27

TH SUFFIX
CASE 314A-03
 Plastic Package
 ISSUE D

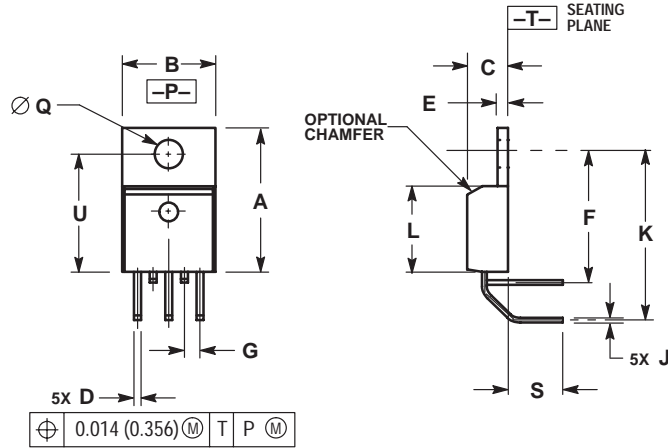
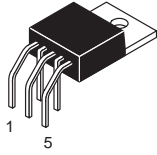

- NOTES:
1. DIMENSIONING AND TOLERANCING PER ANSI Y14.5M, 1982.
 2. CONTROLLING DIMENSION: INCH.
 3. DIMENSION D DOES NOT INCLUDE INTERCONNECT BAR (DAMBAR) PROTRUSION. DIMENSION D INCLUDING PROTRUSION SHALL NOT EXCEED 0.043 (1.092) MAXIMUM.

DIM	INCHES		MILLIMETERS	
	MIN	MAX	MIN	MAX
A	0.572	0.613	14.529	15.570
B	0.390	0.415	9.906	10.541
C	0.170	0.180	4.318	4.572
D	0.025	0.038	0.635	0.965
E	0.048	0.055	1.219	1.397
F	0.570	0.585	14.478	14.859
G	0.067 BSC		1.702 BSC	
J	0.015	0.025	0.381	0.635
K	0.730	0.745	18.542	18.923
L	0.320	0.365	8.128	9.271
Q	0.140	0.153	3.556	3.886
S	0.210	0.260	5.334	6.604
U	0.468	0.505	11.888	12.827

T, TV SUFFIX
CASE 314B-05
 Plastic Package
 ISSUE J

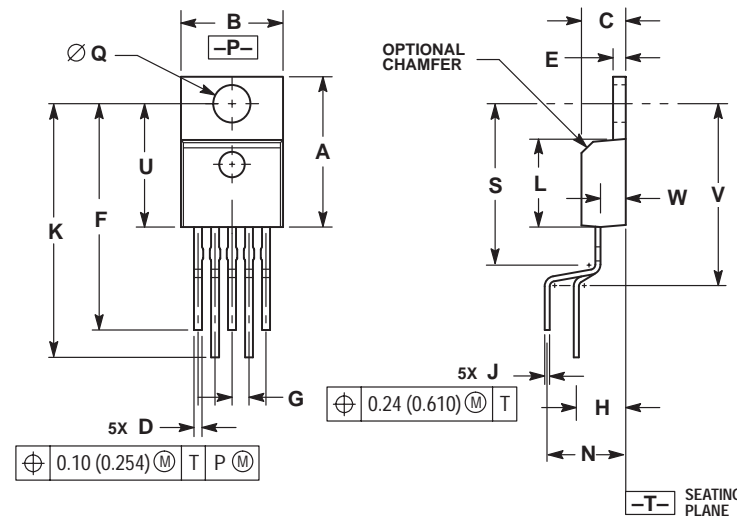
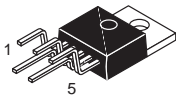

- NOTES:
1. DIMENSIONING AND TOLERANCING PER ANSI Y14.5M, 1982.
 2. CONTROLLING DIMENSION: INCH.
 3. DIMENSION D DOES NOT INCLUDE INTERCONNECT BAR (DAMBAR) PROTRUSION. DIMENSION D INCLUDING PROTRUSION SHALL NOT EXCEED 0.043 (1.092) MAXIMUM.

DIM	INCHES		MILLIMETERS	
	MIN	MAX	MIN	MAX
A	0.572	0.613	14.529	15.570
B	0.390	0.415	9.906	10.541
C	0.170	0.180	4.318	4.572
D	0.025	0.038	0.635	0.965
E	0.048	0.055	1.219	1.397
F	0.850	0.935	21.590	23.749
G	0.067 BSC		1.702 BSC	
H	0.166 BSC		4.216 BSC	
J	0.015	0.025	0.381	0.635
K	0.900	1.100	22.860	27.940
L	0.320	0.365	8.128	9.271
N	0.320 BSC		8.128 BSC	
Q	0.140	0.153	3.556	3.886
S	---	0.620	---	15.748
U	0.468	0.505	11.888	12.827
V	---	0.735	---	18.669
W	0.090	0.110	2.286	2.794

T SUFFIX
CASE 314C-01
 Plastic Package
 ISSUE A

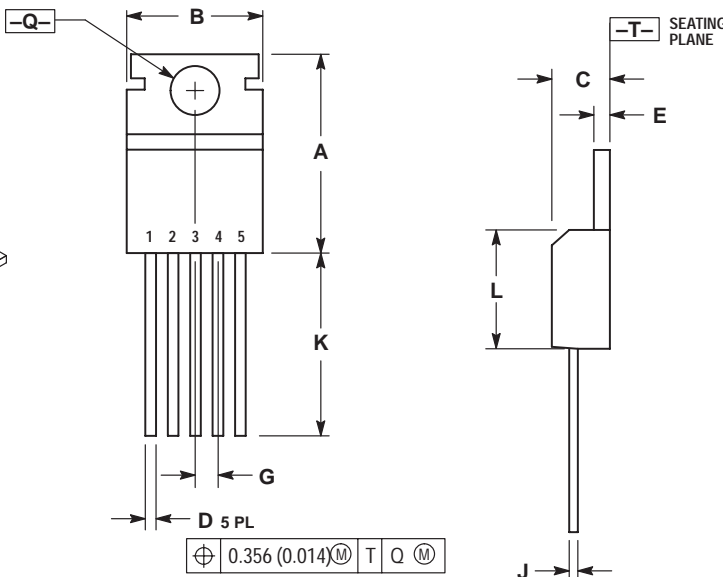
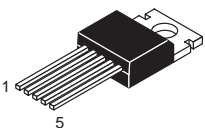

- NOTES:
1. DIMENSIONING AND TOLERANCING PER ANSI Y14.5M, 1982.
 2. CONTROLLING DIMENSION: INCH.
 3. DIMENSION D DOES NOT INCLUDE INTERCONNECT BAR (DAMBAR) PROTRUSION. DIMENSION D INCLUDING PROTRUSION SHALL NOT EXCEED 10.92 (0.043) MAXIMUM.

DIM	INCHES		MILLIMETERS	
	MIN	MAX	MIN	MAX
A	0.610	0.625	15.59	15.88
B	0.380	0.420	9.65	10.67
C	0.160	0.190	4.06	4.83
D	0.020	0.040	0.51	1.02
E	0.035	0.055	0.89	1.40
G	0.067 BSC		1.702 BSC	
J	0.015	0.025	0.38	0.64
K	0.500	---	12.70	---
L	0.355	0.370	9.02	9.40
Q	0.139	0.147	3.53	3.73

T, T1 SUFFIX
CASE 314D-03
 Plastic Package
 ISSUE D

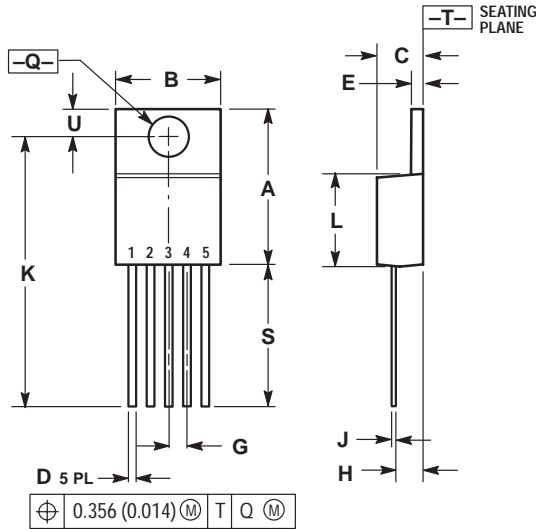
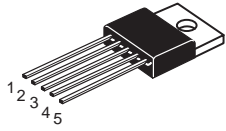

- NOTES:
1. DIMENSIONING AND TOLERANCING PER ANSI Y14.5M, 1982.
 2. CONTROLLING DIMENSION: INCH.
 3. DIMENSION D DOES NOT INCLUDE INTERCONNECT BAR (DAMBAR) PROTRUSION. DIMENSION D INCLUDING PROTRUSION SHALL NOT EXCEED 10.92 (0.043) MAXIMUM.

DIM	INCHES		MILLIMETERS	
	MIN	MAX	MIN	MAX
A	0.572	0.613	14.529	15.570
B	0.390	0.415	9.906	10.541
C	0.170	0.180	4.318	4.572
D	0.025	0.038	0.635	0.965
E	0.048	0.055	1.219	1.397
G	0.067 BSC		1.702 BSC	
H	0.087	0.112	2.210	2.845
J	0.015	0.025	0.381	0.635
K	1.020	1.065	25.908	27.051
L	0.320	0.365	8.128	9.271
Q	0.140	0.153	3.556	3.886
U	0.105	0.117	2.667	2.972
S	0.543	0.582	13.792	14.783

$\oplus 0.356 (0.014) \text{ (M) T Q (M)}$

DT-1 SUFFIX
CASE 369-07
 Plastic Package (DPAK)
 ISSUE K

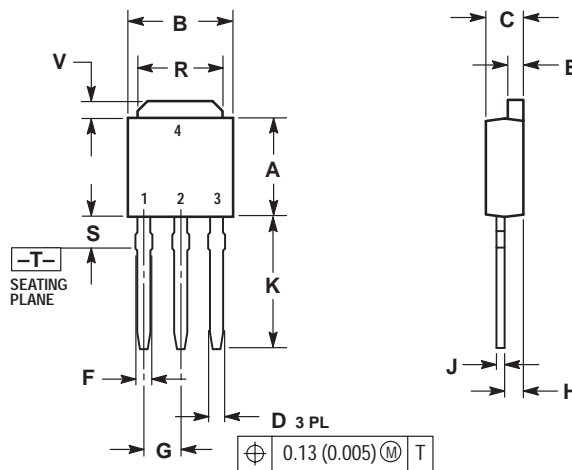
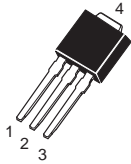

- NOTES:
1. DIMENSIONING AND TOLERANCING PER ANSI Y14.5M, 1982.
 2. CONTROLLING DIMENSION: INCH.

DIM	INCHES		MILLIMETERS	
	MIN	MAX	MIN	MAX
A	0.235	0.250	5.97	6.35
B	0.250	0.265	6.35	6.73
C	0.086	0.094	2.19	2.38
D	0.027	0.035	0.69	0.88
E	0.033	0.040	0.84	1.01
F	0.037	0.047	0.94	1.19
G	0.090 BSC		2.29 BSC	
H	0.034	0.040	0.87	1.01
J	0.018	0.023	0.46	0.58
K	0.350	0.380	8.89	9.65
R	0.175	0.215	4.45	5.46
S	0.050	0.090	1.27	2.28
V	0.030	0.050	0.77	1.27

$\oplus 0.13 (0.005) \text{ (M) T}$

DT SUFFIX
CASE 369A-13
 Plastic Package (DPAK)
 ISSUE Y

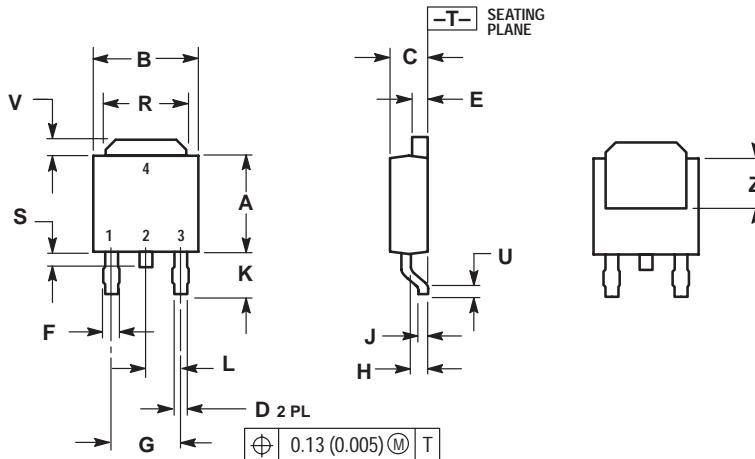
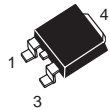

- NOTES:
1. DIMENSIONING AND TOLERANCING PER ANSI Y14.5M, 1982.
 2. CONTROLLING DIMENSION: INCH.

DIM	INCHES		MILLIMETERS	
	MIN	MAX	MIN	MAX
A	0.235	0.250	5.97	6.35
B	0.250	0.265	6.35	6.73
C	0.086	0.094	2.19	2.38
D	0.027	0.035	0.69	0.88
E	0.033	0.040	0.84	1.01
F	0.037	0.047	0.94	1.19
G	0.180 BSC		4.58 BSC	
H	0.034	0.040	0.87	1.01
J	0.018	0.023	0.46	0.58
K	0.102	0.114	2.60	2.89
L	0.090 BSC		2.29 BSC	
R	0.175	0.215	4.45	5.46
S	0.020	0.050	0.51	1.27
U	0.020	---	0.51	---
V	0.030	0.050	0.77	1.27
Z	0.138	---	3.51	---

$\oplus 0.13 (0.005) \text{ (M) T}$

DP1, N, P, P1 SUFFIX
CASE 626-05
 Plastic Package
 ISSUE K

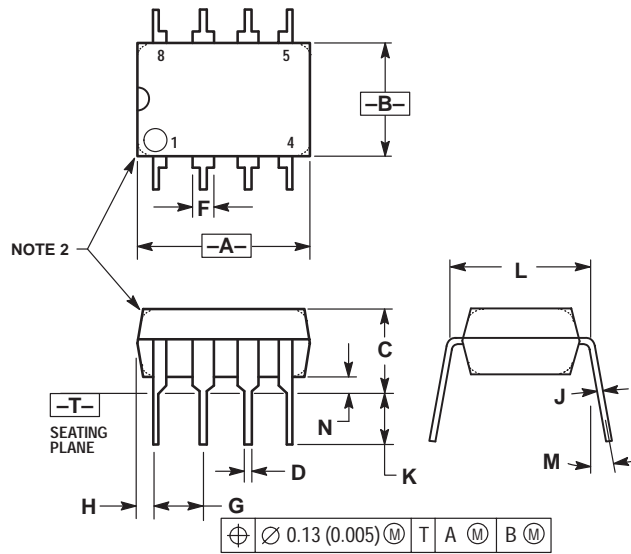
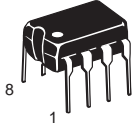

- NOTES:
1. DIMENSION L TO CENTER OF LEAD WHEN FORMED PARALLEL.
 2. PACKAGE CONTOUR OPTIONAL (ROUND OR SQUARE CORNERS).
 3. DIMENSIONING AND TOLERANCING PER ANSI Y14.5M, 1982.

DIM	MILLIMETERS		INCHES	
	MIN	MAX	MIN	MAX
A	9.40	10.16	0.370	0.400
B	6.10	6.60	0.240	0.260
C	3.94	4.45	0.155	0.175
D	0.38	0.51	0.015	0.020
F	1.02	1.78	0.040	0.070
G	2.54 BSC		0.100 BSC	
H	0.76	1.27	0.030	0.050
J	0.20	0.30	0.008	0.012
K	2.92	3.43	0.115	0.135
L	7.62 BSC		0.300 BSC	
M	— 10°		— 10°	
N	0.76	1.01	0.030	0.040

N, P, N-14, P2 SUFFIX
CASE 646-06
 Plastic Package
 ISSUE L

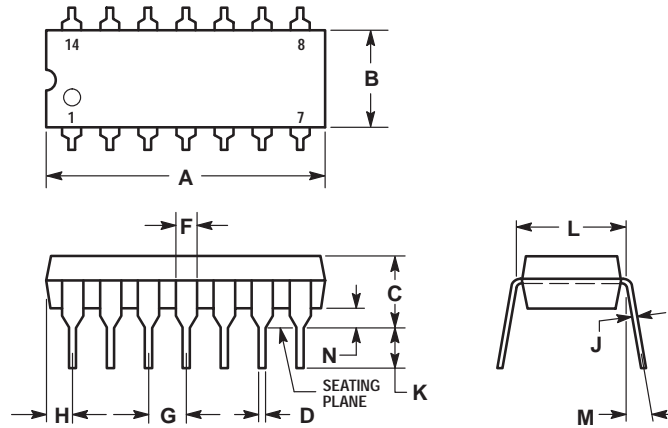
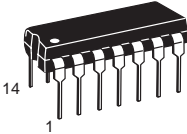

- NOTES:
1. LEADS WITHIN 0.13 (0.005) RADIUS OF TRUE POSITION AT SEATING PLANE AT MAXIMUM MATERIAL CONDITION.
 2. DIMENSION L TO CENTER OF LEADS WHEN FORMED PARALLEL.
 3. DIMENSION B DOES NOT INCLUDE MOLD FLASH.
 4. ROUNDED CORNERS OPTIONAL.

DIM	INCHES		MILLIMETERS	
	MIN	MAX	MIN	MAX
A	0.715	0.770	18.16	19.56
B	0.240	0.260	6.10	6.60
C	0.145	0.185	3.69	4.69
D	0.015	0.021	0.38	0.53
F	0.040	0.070	1.02	1.78
G	0.100 BSC		2.54 BSC	
H	0.052	0.095	1.32	2.41
J	0.008	0.015	0.20	0.38
K	0.115	0.135	2.92	3.43
L	0.300 BSC		7.62 BSC	
M	0° 10°		0° 10°	
N	0.015	0.039	0.39	1.01

DP2, N, P, PC SUFFIX
CASE 648-08
 Plastic Package
 ISSUE R

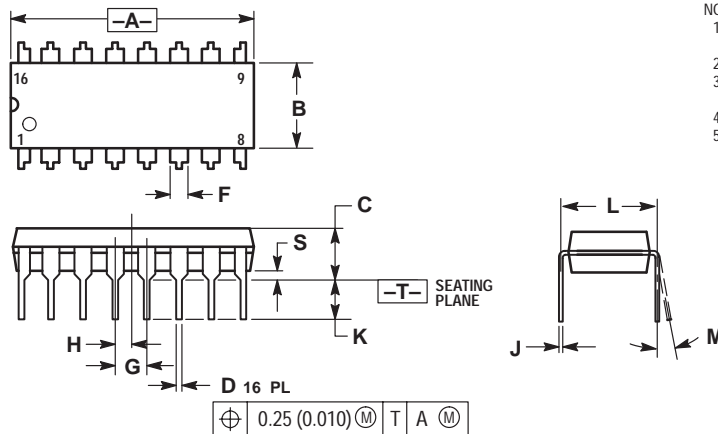
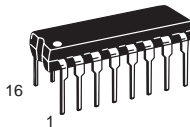

- NOTES:
1. DIMENSIONING AND TOLERANCING PER ANSI Y14.5M, 1982.
 2. CONTROLLING DIMENSION: INCH.
 3. DIMENSION L TO CENTER OF LEADS WHEN FORMED PARALLEL.
 4. DIMENSION B DOES NOT INCLUDE MOLD FLASH.
 5. ROUNDED CORNERS OPTIONAL.

DIM	INCHES		MILLIMETERS	
	MIN	MAX	MIN	MAX
A	0.740	0.770	18.80	19.55
B	0.250	0.270	6.35	6.85
C	0.145	0.175	3.69	4.44
D	0.015	0.021	0.39	0.53
F	0.040	0.70	1.02	1.77
G	0.100 BSC		2.54 BSC	
H	0.050 BSC		1.27 BSC	
J	0.008	0.015	0.21	0.38
K	0.110	0.130	2.80	3.30
L	0.295	0.305	7.50	7.74
M	0° 10°		0° 10°	
S	0.020	0.040	0.51	1.01

B, P, P2, V SUFFIX
CASE 648C-03
 Plastic Package
 (DIP-16)
 ISSUE C

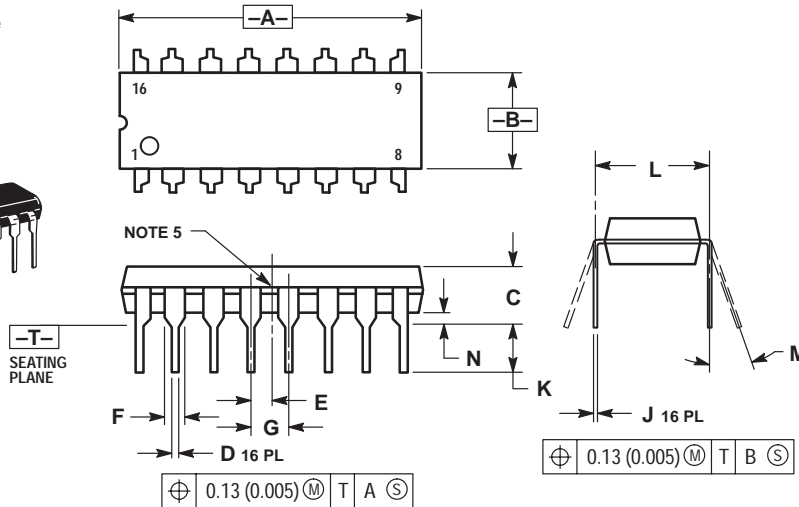
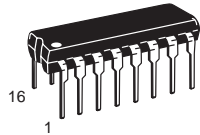

- NOTES:
1. DIMENSIONING AND TOLERANCING PER ANSI Y14.5M, 1982.
 2. CONTROLLING DIMENSION: INCH.
 3. DIMENSION L TO CENTER OF LEADS WHEN FORMED PARALLEL.
 4. DIMENSION B DOES NOT INCLUDE MOLD FLASH.
 5. INTERNAL LEAD CONNECTION BETWEEN 4 AND 5, 12 AND 13.

DIM	INCHES		MILLIMETERS	
	MIN	MAX	MIN	MAX
A	0.740	0.840	18.80	21.34
B	0.240	0.260	6.10	6.60
C	0.145	0.185	3.69	4.69
D	0.015	0.021	0.38	0.53
E	0.050 BSC			
F	0.040	0.70	1.02	1.78
G	0.100 BSC			
J	0.008	0.015	0.20	0.38
K	0.115	0.135	2.92	3.43
L	0.300 BSC			
M	0°	10°	0°	10°
N	0.015	0.040	0.39	1.01

P SUFFIX
CASE 648E-01
 Plastic Package
 (DIP-16)
 ISSUE O

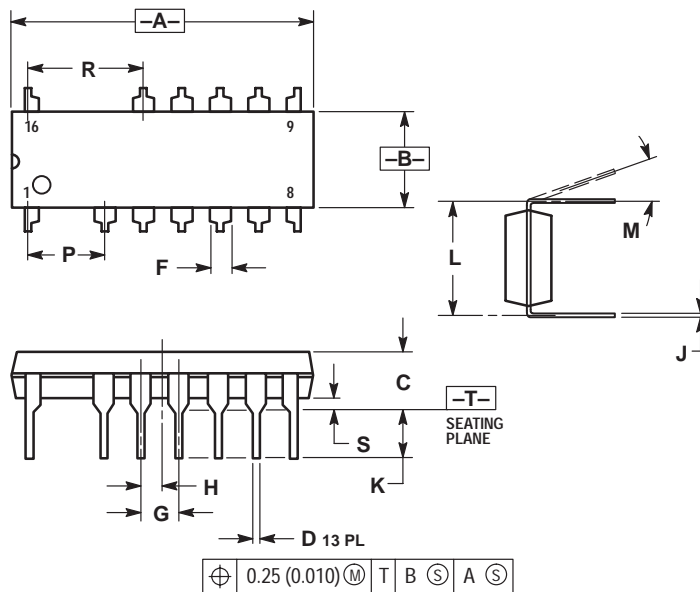
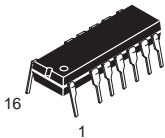

- NOTES:
1. DIMENSIONING AND TOLERANCING PER ANSI Y14.5M, 1982.
 2. CONTROLLING DIMENSION: INCH.
 3. DIMENSION L TO CENTER OF LEADS WHEN FORMED PARALLEL.
 4. DIMENSION A AND B DOES NOT INCLUDE MOLD PROTRUSION.
 5. MOLD FLASH OR PROTRUSIONS SHALL NOT EXCEED 0.25 (0.010).
 6. ROUNDED CORNER OPTIONAL.

DIM	INCHES		MILLIMETERS	
	MIN	MAX	MIN	MAX
A	0.740	0.760	18.80	19.30
B	0.245	0.260	6.23	6.60
C	0.145	0.175	3.69	4.44
D	0.015	0.021	0.39	0.53
F	0.050	0.070	1.27	1.77
G	0.100 BSC			
H	0.050 BSC			
J	0.008	0.015	0.21	0.38
K	0.120	0.140	3.05	3.55
L	0.295	0.305	7.50	7.74
M	0°	10°	0°	10°
P	0.200 BSC			
R	0.300 BSC			
S	0.015	0.035	0.39	0.88

P SUFFIX
CASE 649-03
 Plastic Package
 ISSUE D

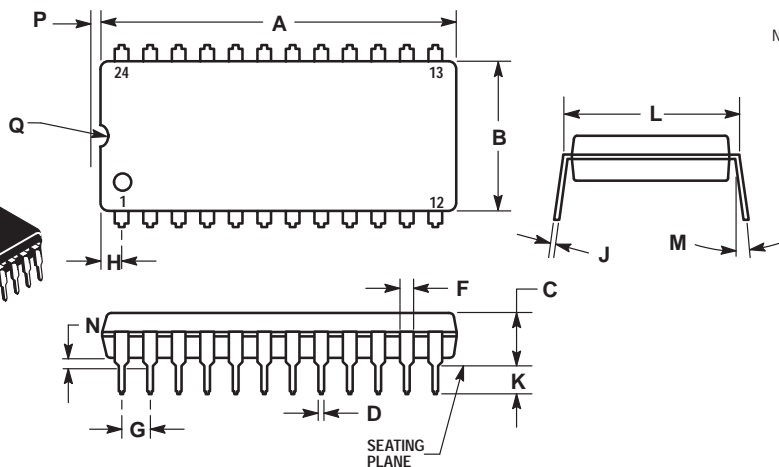
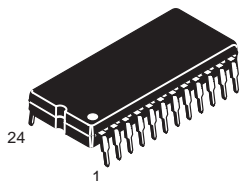

- NOTES:
1. LEADS WITHIN 0.13 (0.005) RADIUS OF TRUE POSITION AT SEATING PLANE AT MAXIMUM MATERIAL CONDITION.
 2. DIMENSION L TO CENTER OF LEADS WHEN FORMED PARALLEL.

DIM	MILLIMETERS		INCHES	
	MIN	MAX	MIN	MAX
A	31.50	32.13	1.240	1.265
B	13.21	13.72	0.520	0.540
C	4.70	5.21	0.185	0.205
D	0.38	0.51	0.015	0.020
F	1.02	1.52	0.040	0.060
G	2.54 BSC		0.100 BSC	
H	1.65	2.16	0.065	0.085
J	0.20	0.30	0.008	0.012
K	2.92	3.43	0.115	0.135
L	14.99	15.49	0.590	0.610
M	---	10	---	10°
N	0.51	1.02	0.020	0.040
P	0.13	0.38	0.005	0.015
Q	0.51	0.76	0.020	0.030

A, B, N, P SUFFIX
CASE 707-02
 Plastic Package
 ISSUE C

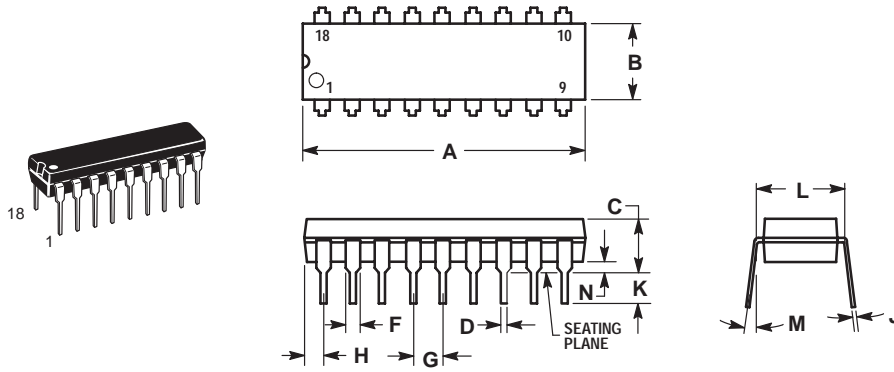

- NOTES:
1. POSITIONAL TOLERANCE OF LEADS (D), SHALL BE WITHIN 0.25 (0.010) AT MAXIMUM MATERIAL CONDITION, IN RELATION TO SEATING PLANE AND EACH OTHER.
 2. DIMENSION L TO CENTER OF LEADS WHEN FORMED PARALLEL.
 3. DIMENSION B DOES NOT INCLUDE MOLD FLASH.

DIM	MILLIMETERS		INCHES	
	MIN	MAX	MIN	MAX
A	22.22	23.24	0.875	0.915
B	6.10	6.60	0.240	0.260
C	3.56	4.57	0.140	0.180
D	0.36	0.56	0.014	0.022
F	1.27	1.78	0.050	0.070
G	2.54 BSC		0.100 BSC	
H	1.02	1.52	0.040	0.060
J	0.20	0.30	0.008	0.012
K	2.92	3.43	0.115	0.135
L	7.62 BSC		0.300 BSC	
M	0°	15°	0°	15°
N	0.51	1.02	0.020	0.040

P SUFFIX
CASE 710-02
 Plastic Package
 ISSUE B

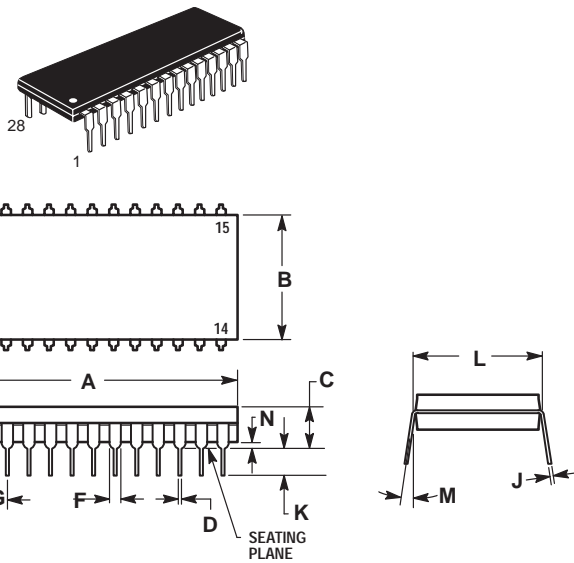

- NOTES:
1. POSITIONAL TOLERANCE OF LEADS (D), SHALL BE WITHIN 0.25 (0.010) AT MAXIMUM MATERIAL CONDITION, IN RELATION TO SEATING PLANE AND EACH OTHER.
 2. DIMENSION L TO CENTER OF LEADS WHEN FORMED PARALLEL.
 3. DIMENSION B DOES NOT INCLUDE MOLD FLASH.

DIM	MILLIMETERS		INCHES	
	MIN	MAX	MIN	MAX
A	36.45	37.21	1.435	1.465
B	13.72	14.22	0.540	0.560
C	3.94	5.08	0.155	0.200
D	0.36	0.56	0.014	0.022
F	1.02	1.52	0.040	0.060
G	2.54 BSC		0.100 BSC	
H	1.65	2.16	0.065	0.085
J	0.20	0.38	0.008	0.015
K	2.92	3.43	0.115	0.135
L	15.24 BSC		0.600 BSC	
M	0°	15°	0°	15°
N	0.51	1.02	0.020	0.040

P SUFFIX
CASE 711-03
 Plastic Package
 ISSUE C

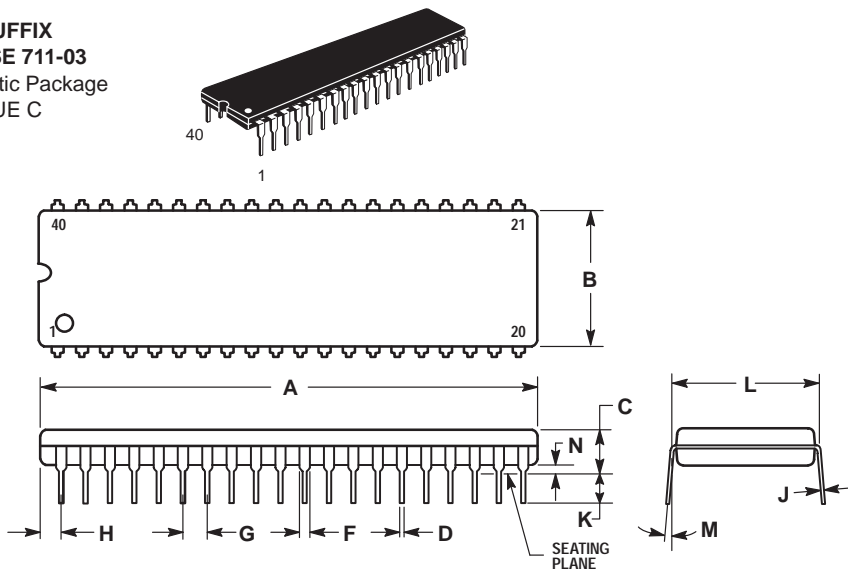

- NOTES:
1. POSITIONAL TOLERANCE OF LEADS (D), SHALL BE WITHIN 0.25 (0.010) AT MAXIMUM MATERIAL CONDITION, IN RELATION TO SEATING PLANE AND EACH OTHER.
 2. DIMENSION L TO CENTER OF LEADS WHEN FORMED PARALLEL.
 3. DIMENSION B DOES NOT INCLUDE MOLD FLASH.

DIM	MILLIMETERS		INCHES	
	MIN	MAX	MIN	MAX
A	51.69	52.45	2.035	2.065
B	13.72	14.22	0.540	0.560
C	3.94	5.08	0.155	0.200
D	0.36	0.56	0.014	0.022
F	1.02	1.52	0.040	0.060
G	2.54 BSC		0.100 BSC	
H	1.65	2.16	0.065	0.085
J	0.20	0.38	0.008	0.015
K	2.92	3.43	0.115	0.135
L	15.24 BSC		0.600 BSC	
M	0°	15°	0°	15°
N	0.51	1.02	0.020	0.040

F, P, P-3 SUFFIX
CASE 724-03
 Plastic Package
 (NDIP-24)
 ISSUE D

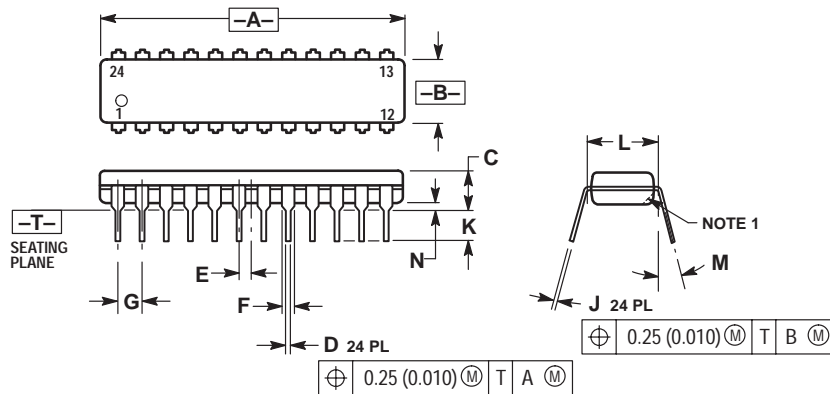
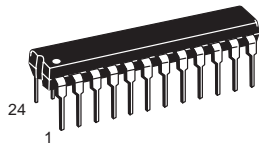

- NOTES:
1. CHAMFERED CONTOUR OPTIONAL.
 2. DIMENSION L TO CENTER OF LEADS WHEN FORMED PARALLEL.
 3. DIMENSIONING AND TOLERANCING PER ANSI Y14.5M, 1982.
 4. CONTROLLING DIMENSION: INCH.

DIM	INCHES		MILLIMETERS	
	MIN	MAX	MIN	MAX
A	1.230	1.265	31.25	32.13
B	0.250	0.270	6.35	6.85
C	0.145	0.175	3.69	4.44
D	0.015	0.020	0.38	0.51
E	0.050 BSC		1.27 BSC	
F	0.040	0.060	1.02	1.52
G	0.100 BSC		2.54 BSC	
J	0.007	0.012	0.18	0.30
K	0.110	0.140	2.80	3.55
L	0.300 BSC		7.62 BSC	
M	0°	15°	0°	15°
N	0.020	0.040	0.51	1.01

H, P, DP SUFFIX
CASE 738-03
 Plastic Package
 ISSUE E

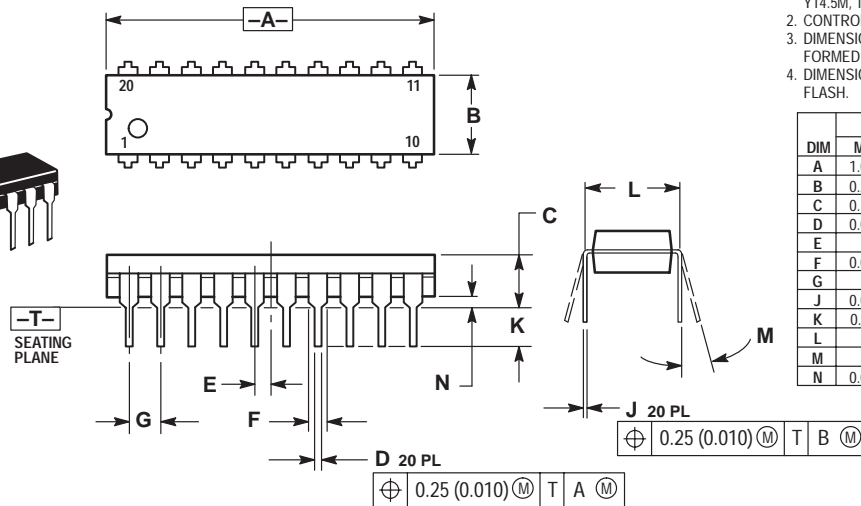
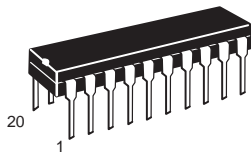

- NOTES:
1. DIMENSIONING AND TOLERANCING PER ANSI Y14.5M, 1982.
 2. CONTROLLING DIMENSION: INCH.
 3. DIMENSION L TO CENTER OF LEAD WHEN FORMED PARALLEL.
 4. DIMENSION B DOES NOT INCLUDE MOLD FLASH.

DIM	INCHES		MILLIMETERS	
	MIN	MAX	MIN	MAX
A	1.010	1.070	25.66	27.17
B	0.240	0.260	6.10	6.60
C	0.150	0.180	3.81	4.57
D	0.015	0.022	0.39	0.55
E	0.050 BSC		1.27 BSC	
F	0.050	0.070	1.27	1.77
G	0.100 BSC		2.54 BSC	
J	0.008	0.015	0.21	0.38
K	0.110	0.140	2.80	3.55
L	0.300 BSC		7.62 BSC	
M	0°	15°	0°	15°
N	0.020	0.040	0.51	1.01

D, D1, D2 SUFFIX
CASE 751-05
 Plastic Package
 (SO-8, SOP-8)
 ISSUE R

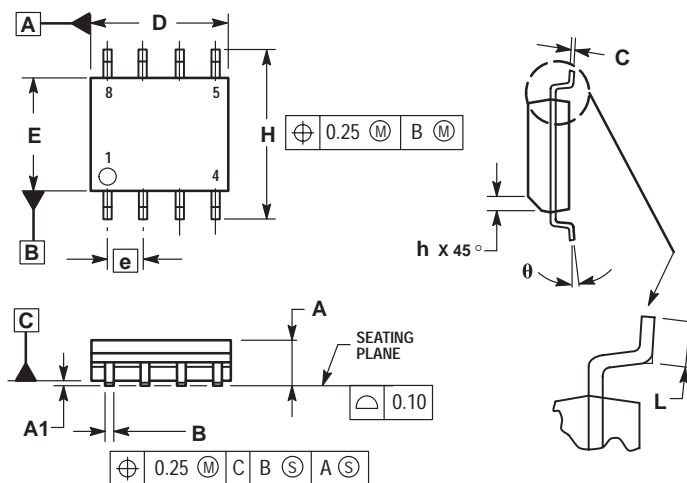

- NOTES:
1. DIMENSIONING AND TOLERANCING PER ASME Y14.5M, 1994.
 2. DIMENSIONS ARE IN MILLIMETERS.
 3. DIMENSION D AND E DO NOT INCLUDE MOLD PROTRUSION.
 4. MAXIMUM MOLD PROTRUSION 0.15 PER SIDE.
 5. DIMENSION B DOES NOT INCLUDE MOLD PROTRUSION. ALLOWABLE DAMBAR PROTRUSION SHALL BE 0.127 TOTAL IN EXCESS OF THE B DIMENSION AT MAXIMUM MATERIAL CONDITION.

DIM	MILLIMETERS	
	MIN	MAX
A	1.35	1.75
A1	0.10	0.25
B	0.35	0.49
C	0.18	0.25
D	4.80	5.00
E	3.80	4.00
e	1.27 BSC	
H	5.80	6.20
h	0.25	0.50
L	0.40	1.25
θ	0°	7°

D SUFFIX
CASE 751A-03
 Plastic Package
 (SO-14)
 ISSUE F

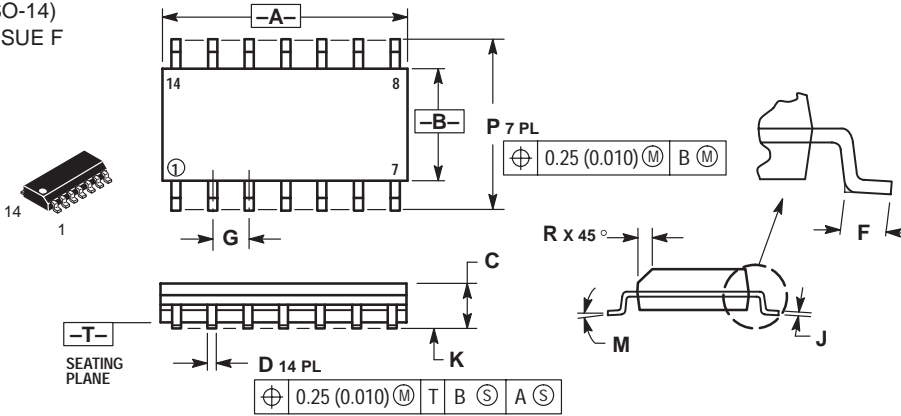

- NOTES:
1. DIMENSIONING AND TOLERANCING PER ANSI Y14.5M, 1982.
 2. CONTROLLING DIMENSION: MILLIMETER.
 3. DIMENSIONS A AND B DO NOT INCLUDE MOLD PROTRUSION.
 4. MAXIMUM MOLD PROTRUSION 0.15 (0.006) PER SIDE.
 5. DIMENSION D DOES NOT INCLUDE DAMBAR PROTRUSION. ALLOWABLE DAMBAR PROTRUSION SHALL BE 0.127 (0.005) TOTAL IN EXCESS OF THE D DIMENSION AT MAXIMUM MATERIAL CONDITION.

DIM	MILLIMETERS		INCHES	
	MIN	MAX	MIN	MAX
A	8.55	8.75	0.337	0.344
B	3.80	4.00	0.150	0.157
C	1.35	1.75	0.054	0.068
D	0.35	0.49	0.014	0.019
F	0.40	1.25	0.016	0.049
G	1.27 BSC		0.050 BSC	
J	0.19	0.25	0.008	0.009
K	0.10	0.25	0.004	0.009
M	0°	7°	0°	7°
P	5.80	6.20	0.228	0.244
R	0.25	0.50	0.010	0.019

D SUFFIX
CASE 751B-05
 Plastic Package
 (SO-16)
 ISSUE J

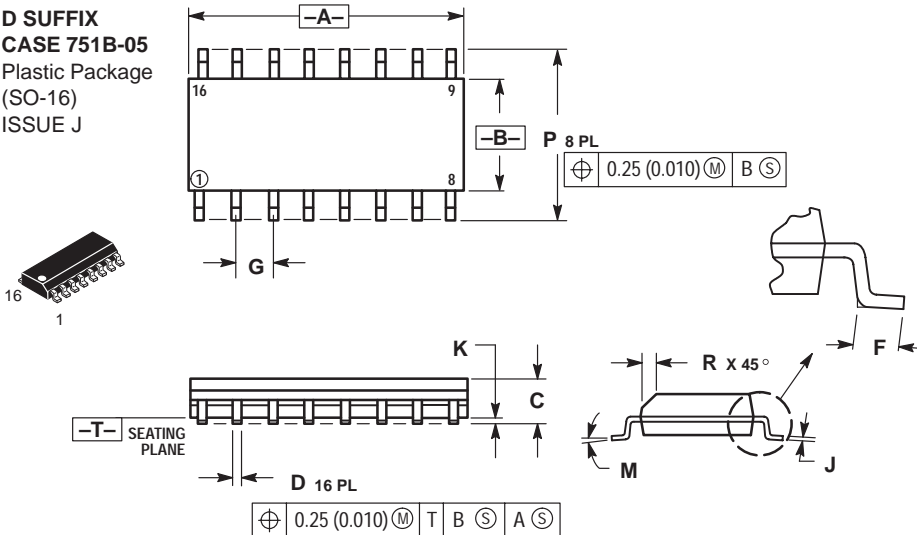

- NOTES:
1. DIMENSIONING AND TOLERANCING PER ANSI Y14.5M, 1982.
 2. CONTROLLING DIMENSION: MILLIMETER.
 3. DIMENSIONS A AND B DO NOT INCLUDE MOLD PROTRUSION.
 4. MAXIMUM MOLD PROTRUSION 0.15 (0.006) PER SIDE.
 5. DIMENSION D DOES NOT INCLUDE DAMBAR PROTRUSION. ALLOWABLE DAMBAR PROTRUSION SHALL BE 0.127 (0.005) TOTAL IN EXCESS OF THE D DIMENSION AT MAXIMUM MATERIAL CONDITION.

DIM	MILLIMETERS		INCHES	
	MIN	MAX	MIN	MAX
A	9.80	10.00	0.386	0.393
B	3.80	4.00	0.150	0.157
C	1.35	1.75	0.054	0.068
D	0.35	0.49	0.014	0.019
F	0.40	1.25	0.016	0.049
G	1.27 BSC		0.050 BSC	
J	0.19	0.25	0.008	0.009
K	0.10	0.25	0.004	0.009
M	0°	7°	0°	7°
P	5.80	6.20	0.229	0.244
R	0.25	0.50	0.010	0.019

DW, FP SUFFIX
CASE 751D-04
 Plastic Package
 (SO-20L, SO-20)
 ISSUE E

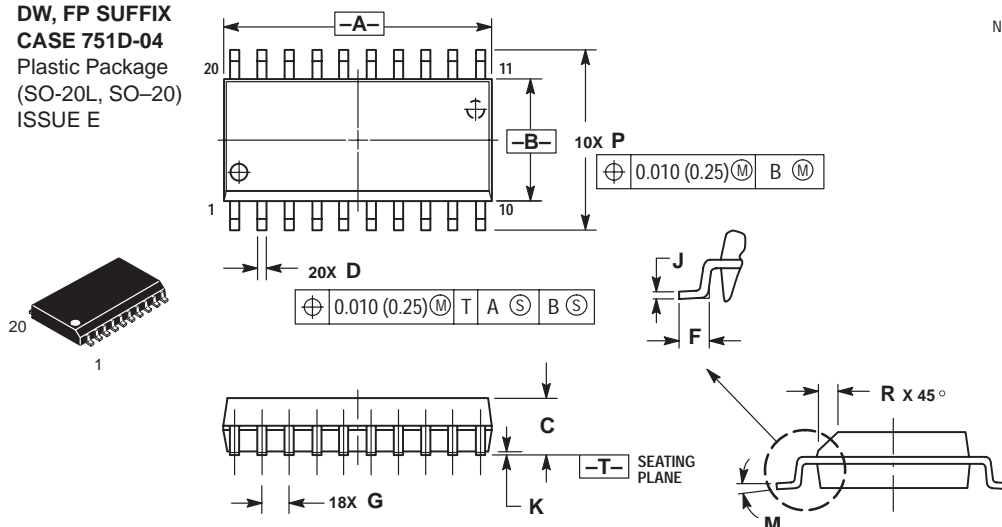

- NOTES:
1. DIMENSIONING AND TOLERANCING PER ANSI Y14.5M, 1982.
 2. CONTROLLING DIMENSION: MILLIMETER.
 3. DIMENSIONS A AND B DO NOT INCLUDE MOLD PROTRUSION.
 4. MAXIMUM MOLD PROTRUSION 0.150 (0.006) PER SIDE.
 5. DIMENSION D DOES NOT INCLUDE DAMBAR PROTRUSION. ALLOWABLE DAMBAR PROTRUSION SHALL BE 0.13 (0.005) TOTAL IN EXCESS OF D DIMENSION AT MAXIMUM MATERIAL CONDITION.

DIM	MILLIMETERS		INCHES	
	MIN	MAX	MIN	MAX
A	12.65	12.95	0.499	0.510
B	7.40	7.60	0.292	0.299
C	2.35	2.65	0.093	0.104
D	0.35	0.49	0.014	0.019
F	0.50	0.90	0.020	0.035
G	1.27 BSC		0.050 BSC	
J	0.25	0.32	0.010	0.012
K	0.10	0.25	0.004	0.009
M	0°	7°	0°	7°
P	10.05	10.55	0.395	0.415
R	0.25	0.75	0.010	0.029

DW SUFFIX
CASE 751E-04
 Plastic Package
 (SO-24L,
 SOP (16+4+4)L)
 ISSUE E

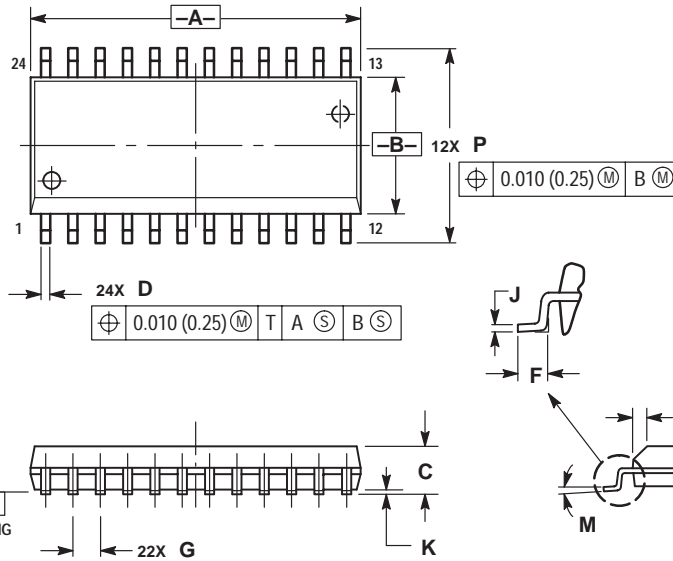
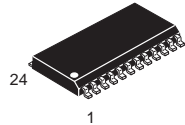

- NOTES:
1. DIMENSIONING AND TOLERANCING PER ANSI Y14.5M, 1982.
 2. CONTROLLING DIMENSION: MILLIMETER.
 3. DIMENSIONS A AND B DO NOT INCLUDE MOLD PROTRUSION.
 4. MAXIMUM MOLD PROTRUSION 0.15 (0.006) PER SIDE.
 5. DIMENSION D DOES NOT INCLUDE DAMBAR PROTRUSION. ALLOWABLE DAMBAR PROTRUSION SHALL BE 0.13 (0.005) TOTAL IN EXCESS OF D DIMENSION AT MAXIMUM MATERIAL CONDITION.

DIM	MILLIMETERS		INCHES	
	MIN	MAX	MIN	MAX
A	15.25	15.54	0.601	0.612
B	7.40	7.60	0.292	0.299
C	2.35	2.65	0.093	0.104
D	0.35	0.49	0.014	0.019
F	0.41	0.90	0.016	0.035
G	1.27 BSC		0.050 BSC	
J	0.23	0.32	0.009	0.013
K	0.13	0.29	0.005	0.011
M	0°	8°	0°	8°
P	10.05	10.55	0.395	0.415
R	0.25	0.75	0.010	0.029

DW SUFFIX
CASE 751F-04
 Plastic Package
 (SO-28L, SOIC-28)
 ISSUE E

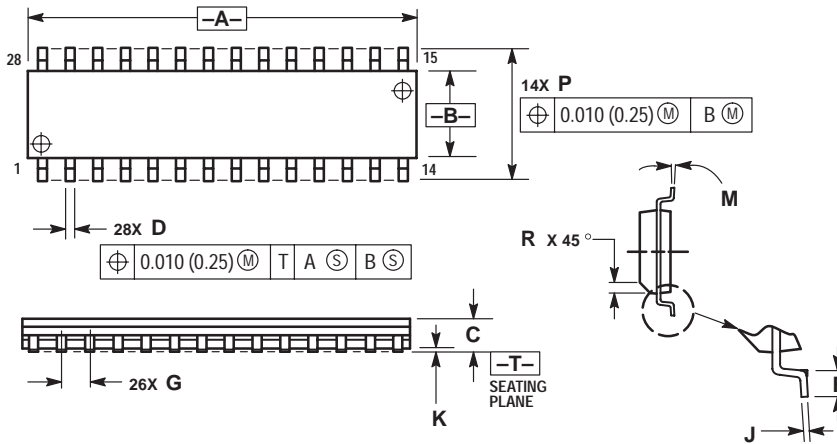
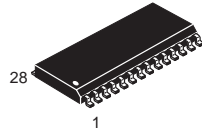

- NOTES:
1. DIMENSIONING AND TOLERANCING PER ANSI Y14.5M, 1982.
 2. CONTROLLING DIMENSION: MILLIMETER.
 3. DIMENSION A AND B DO NOT INCLUDE MOLD PROTRUSION.
 4. MAXIMUM MOLD PROTRUSION 0.15 (0.006) PER SIDE.
 5. DIMENSION D DOES NOT INCLUDE DAMBAR PROTRUSION. ALLOWABLE DAMBAR PROTRUSION SHALL BE 0.13 (0.005) TOTAL IN EXCESS OF D DIMENSION AT MAXIMUM MATERIAL CONDITION.

DIM	MILLIMETERS		INCHES	
	MIN	MAX	MIN	MAX
A	17.80	18.05	0.701	0.711
B	7.40	7.60	0.292	0.299
C	2.35	2.65	0.093	0.104
D	0.35	0.49	0.014	0.019
F	0.41	0.90	0.016	0.035
G	1.27 BSC		0.050 BSC	
J	0.23	0.32	0.009	0.013
K	0.13	0.29	0.005	0.011
M	0°	8°	0°	8°
P	10.01	10.55	0.395	0.415
R	0.25	0.75	0.010	0.029

DW SUFFIX
CASE 751G-02
 Plastic Package
 (SO-16L, SOP-16L,
 SOP-8+8L)
 ISSUE A

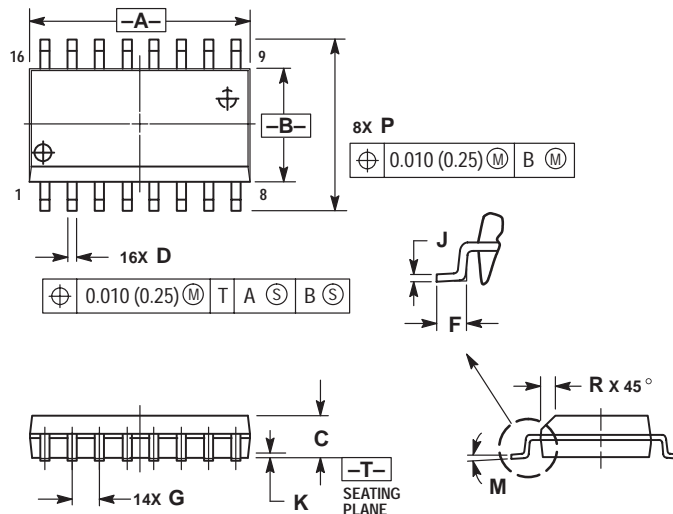
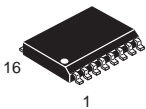

- NOTES:
1. DIMENSIONING AND TOLERANCING PER ANSI Y14.5M, 1982.
 2. CONTROLLING DIMENSION: MILLIMETER.
 3. DIMENSIONS A AND B DO NOT INCLUDE MOLD PROTRUSION.
 4. MAXIMUM MOLD PROTRUSION 0.15 (0.006) PER SIDE.
 5. DIMENSION D DOES NOT INCLUDE DAMBAR PROTRUSION. ALLOWABLE DAMBAR PROTRUSION SHALL BE 0.13 (0.005) TOTAL IN EXCESS OF D DIMENSION AT MAXIMUM MATERIAL CONDITION.

DIM	MILLIMETERS		INCHES	
	MIN	MAX	MIN	MAX
A	10.15	10.45	0.400	0.411
B	7.40	7.60	0.292	0.299
C	2.35	2.65	0.093	0.104
D	0.35	0.49	0.014	0.019
F	0.50	0.90	0.020	0.035
G	1.27 BSC		0.050 BSC	
J	0.25	0.32	0.010	0.012
K	0.10	0.25	0.004	0.009
M	0°	7°	0°	7°
P	10.05	10.55	0.395	0.415
R	0.25	0.75	0.010	0.029

D SUFFIX
CASE 751K-01
 Plastic Package
 (SO-16)
 ISSUE O

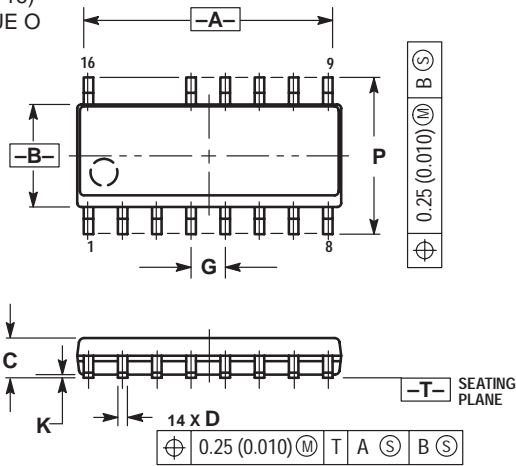
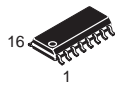

- NOTES:
1. DIMENSIONING AND TOLERANCING PER ANSI Y14.5M, 1982.
 2. CONTROLLING DIMENSION: MILLIMETER.
 3. DIMENSIONS A AND B DO NOT INCLUDE MOLD PROTRUSION.
 4. MAXIMUM MOLD PROTRUSION 0.15 (0.006) PER SIDE.
 5. DIMENSION D DOES NOT INCLUDE DAMBAR PROTRUSION. ALLOWABLE DAMBAR PROTRUSION SHALL BE 0.127 (0.005) TOTAL IN EXCESS OF THE D DIMENSION AT MAXIMUM MATERIAL CONDITION.

DIM	MILLIMETERS		INCHES	
	MIN	MAX	MIN	MAX
A	9.80	10.00	0.368	0.393
B	3.80	4.00	0.150	0.157
C	1.35	1.75	0.054	0.068
D	0.35	0.49	0.014	0.019
F	0.40	1.25	0.016	0.049
G	1.27 BSC		0.050 BSC	
J	0.19	0.25	0.008	0.009
K	0.10	0.25	0.004	0.009
M	0°	7°	0°	7°
P	5.80	6.20	0.229	0.244
R	0.25	0.50	0.010	0.019

DW SUFFIX
CASE 751N-01
 Plastic Package
 (SOP-16L)
 ISSUE O

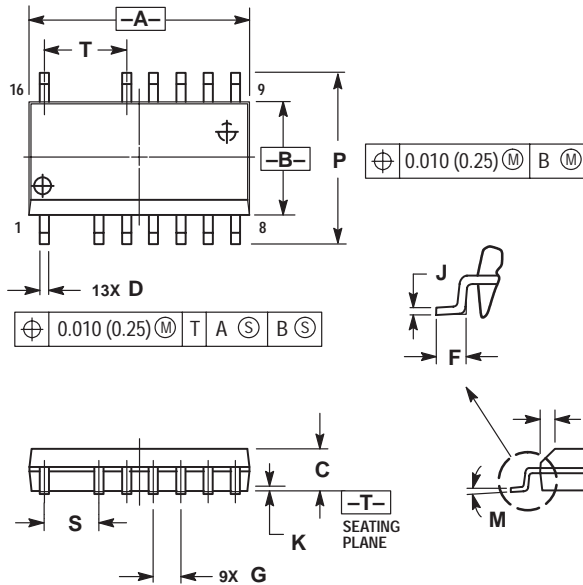
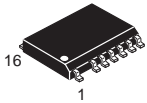

- NOTES:
1. DIMENSIONING AND TOLERANCING PER ANSI Y14.5M, 1982.
 2. CONTROLLING DIMENSION: MILLIMETER.
 3. DIMENSIONS A AND B DO NOT INCLUDE MOLD PROTRUSION.
 4. MAXIMUM MOLD PROTRUSION 0.15 (0.006) PER SIDE.
 5. DIMENSION D DOES NOT INCLUDE DAMBAR PROTRUSION. ALLOWABLE DAMBAR PROTRUSION SHALL BE 0.13 (0.005) TOTAL IN EXCESS OF D DIMENSION AT MAXIMUM MATERIAL CONDITION.

DIM	MILLIMETERS		INCHES	
	MIN	MAX	MIN	MAX
A	10.15	10.45	0.400	0.411
B	7.40	7.60	0.292	0.299
C	2.35	2.65	0.093	0.104
D	0.35	0.49	0.014	0.019
F	0.50	0.90	0.020	0.035
G	1.27 BSC		0.050 BSC	
J	0.25	0.32	0.010	0.012
K	0.10	0.25	0.004	0.009
M	0°	7°	0°	7°
P	10.05	10.55	0.395	0.415
R	0.25	0.75	0.010	0.029
S	2.54 BSC		0.100 BSC	
T	3.81 BSC		0.150 BSC	

CASE 762-01
 Plastic Medium Power Package
 (SIP-9)
 ISSUE C

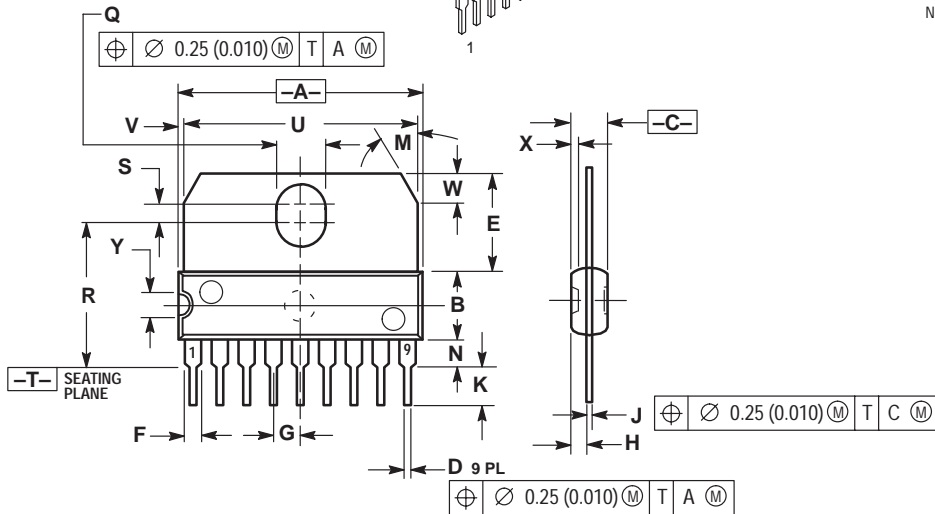
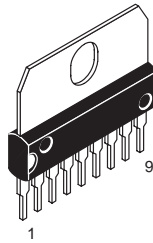

- NOTES:
 1. DIMENSIONING AND TOLERANCING PER ANSI Y14.5, 1982.
 2. CONTROLLING DIMENSION: MILLIMETER.

DIM	MILLIMETERS		INCHES	
	MIN	MAX	MIN	MAX
A	22.40	23.00	0.873	0.897
B	6.40	6.60	0.252	0.260
C	3.45	3.65	0.135	1.143
D	0.40	0.55	0.015	0.021
E	9.35	9.60	0.368	0.377
F	1.40	1.60	0.055	0.062
G	2.54 BSC		0.100 BSC	
H	1.51	1.71	0.059	0.067
J	0.360	0.400	0.014	0.015
K	3.95	4.20	0.155	0.165
M	30° BSC		30° BSC	
N	2.50	2.70	0.099	0.106
Q	3.15	3.45	0.124	0.135
R	13.60	13.90	0.535	0.547
S	1.65	1.95	0.064	0.076
U	22.00	22.20	0.866	0.874
V	0.55	0.75	0.021	0.029
W	2.89 BSC		0.113 BSC	
X	0.65	0.75	0.025	0.029
Y	2.70	2.80	0.106	0.110

FN SUFFIX
CASE 775-02
 Plastic Package
 (PLCC-20)
 ISSUE C

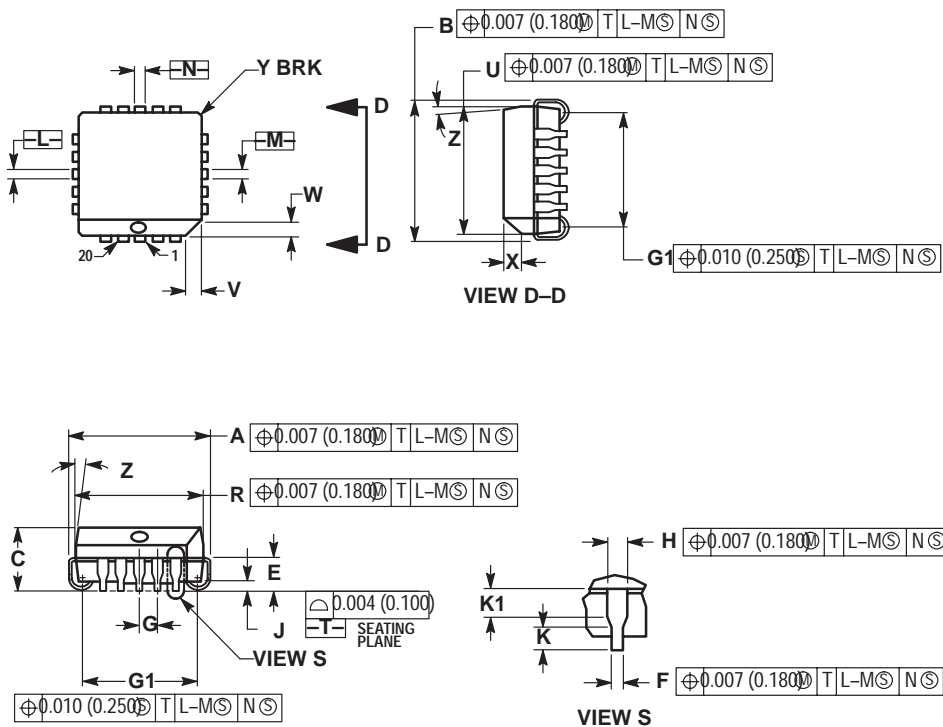
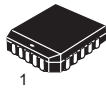

- NOTES:
 1. DATUMS -L-, -M-, AND -N- DETERMINED WHERE TOP OF LEAD SHOULDER EXITS PLASTIC BODY AT MOLD PARTING LINE.
 2. DIMENSION G1, TRUE POSITION TO BE MEASURED AT DATUM -T-, SEATING PLANE.
 3. DIMENSIONS R AND U DO NOT INCLUDE MOLD FLASH. ALLOWABLE MOLD FLASH IS 0.010 (0.250) PER SIDE.
 4. DIMENSIONING AND TOLERANCING PER ANSI Y14.5M, 1982.
 5. CONTROLLING DIMENSION: INCH.
 6. THE PACKAGE TOP MAY BE SMALLER THAN THE PACKAGE BOTTOM BY UP TO 0.012 (0.300). DIMENSIONS R AND U ARE DETERMINED AT THE OUTERMOST EXTREMES OF THE PLASTIC BODY EXCLUSIVE OF MOLD FLASH, TIE BAR BURRS, GATE BURRS AND INTERLEAD FLASH, BUT INCLUDING ANY MISMATCH BETWEEN THE TOP AND BOTTOM OF THE PLASTIC BODY.
 7. DIMENSION H DOES NOT INCLUDE DAMBAR PROTRUSION OR INTRUSION. THE DAMBAR PROTRUSION(S) SHALL NOT CAUSE THE H DIMENSION TO BE GREATER THAN 0.037 (0.940). THE DAMBAR INTRUSION(S) SHALL NOT CAUSE THE H DIMENSION TO BE SMALLER THAN 0.025 (0.635).

DIM	INCHES		MILLIMETERS	
	MIN	MAX	MIN	MAX
A	0.385	0.395	9.78	10.03
B	0.385	0.395	9.78	10.03
C	0.165	0.180	4.20	4.57
E	0.090	0.110	2.29	2.79
F	0.013	0.019	0.33	0.48
G	0.050 BSC		1.27 BSC	
H	0.026	0.032	0.66	0.81
J	0.020	---	0.51	---
K	0.025	---	0.64	---
R	0.350	0.356	8.89	9.04
U	0.350	0.356	8.89	9.04
V	0.042	0.048	1.07	1.21
W	0.042	0.048	1.07	1.21
X	0.042	0.056	1.07	1.42
Y	---	0.020	---	0.50
Z	2°	10°	---	10°
G1	0.310	0.330	7.88	8.38
K1	0.040	---	1.02	---

FN SUFFIX
CASE 776-02
 Plastic Package
 (PLCC-28)
 ISSUE D

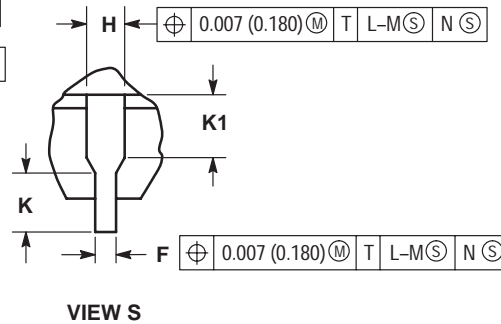
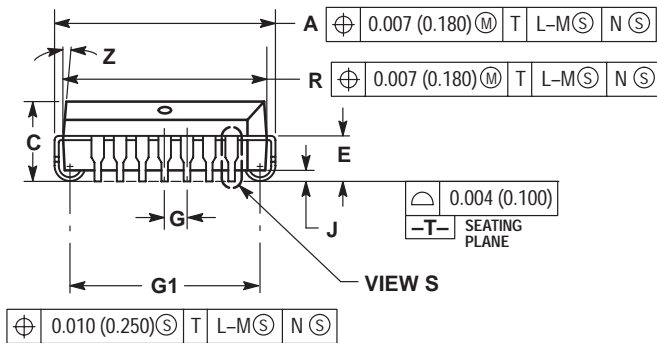
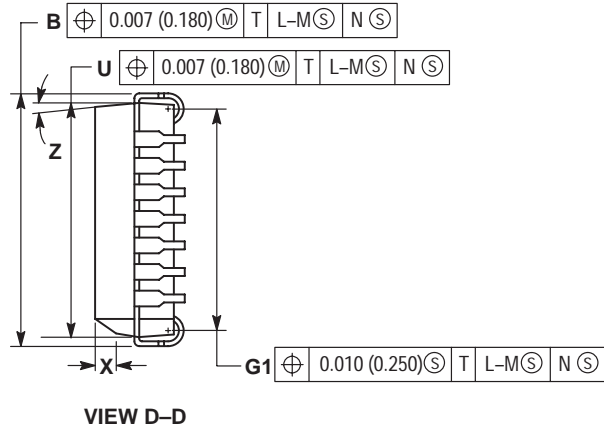
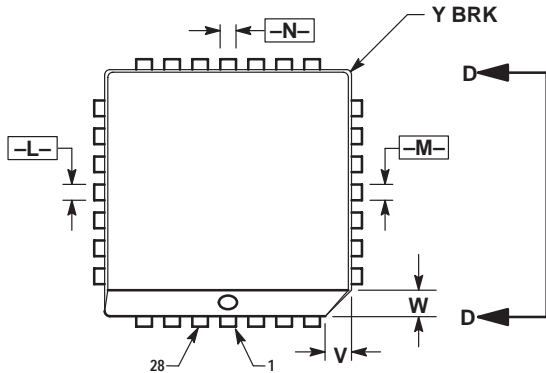
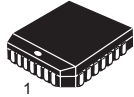

NOTES:

- DATUMS -L-, -M-, AND -N- DETERMINED WHERE TOP OF LEAD SHOULDER EXITS PLASTIC BODY AT MOLD PARTING LINE.
- DIMENSION G1, TRUE POSITION TO BE MEASURED AT DATUM -T-, SEATING PLANE.
- DIMENSIONS R AND U DO NOT INCLUDE MOLD FLASH. ALLOWABLE MOLD FLASH IS 0.010 (0.250) PER SIDE.
- DIMENSIONING AND TOLERANCING PER ANSI Y14.5M, 1982.
- CONTROLLING DIMENSION: INCH.
- THE PACKAGE TOP MAY BE SMALLER THAN THE PACKAGE BOTTOM BY UP TO 0.012 (0.300). DIMENSIONS R AND U ARE DETERMINED AT THE OUTERMOST EXTREMES OF THE PLASTIC BODY EXCLUSIVE OF MOLD FLASH, TIE BAR BURRS, GATE BURRS AND INTERLEAD FLASH, BUT INCLUDING ANY MISMATCH BETWEEN THE TOP AND BOTTOM OF THE PLASTIC BODY.
- DIMENSION H DOES NOT INCLUDE DAMBAR PROTRUSION OR INTRUSION. THE DAMBAR PROTRUSION(S) SHALL NOT CAUSE THE H DIMENSION TO BE GREATER THAN 0.037 (0.940). THE DAMBAR INTRUSION(S) SHALL NOT CAUSE THE H DIMENSION TO BE SMALLER THAN 0.025 (0.635).

DIM	INCHES		MILLIMETERS	
	MIN	MAX	MIN	MAX
A	0.485	0.495	12.32	12.57
B	0.485	0.495	12.32	12.57
C	0.165	0.180	4.20	4.57
E	0.090	0.110	2.29	2.79
F	0.013	0.019	0.33	0.48
G	0.050 BSC		1.27 BSC	
H	0.026	0.032	0.66	0.81
J	0.020	---	0.51	---
K	0.025	---	0.64	---
R	0.450	0.456	11.43	11.58
U	0.450	0.456	11.43	11.58
V	0.042	0.048	1.07	1.21
W	0.042	0.048	1.07	1.21
X	0.042	0.056	1.07	1.42
Y	---	0.020	---	0.50
Z	2°	10°	2°	10°
G1	0.410	0.430	10.42	10.92
K1	0.040	---	1.02	---

FN SUFFIX
CASE 777-02
 Plastic Package
 (PLCC)
 ISSUE C

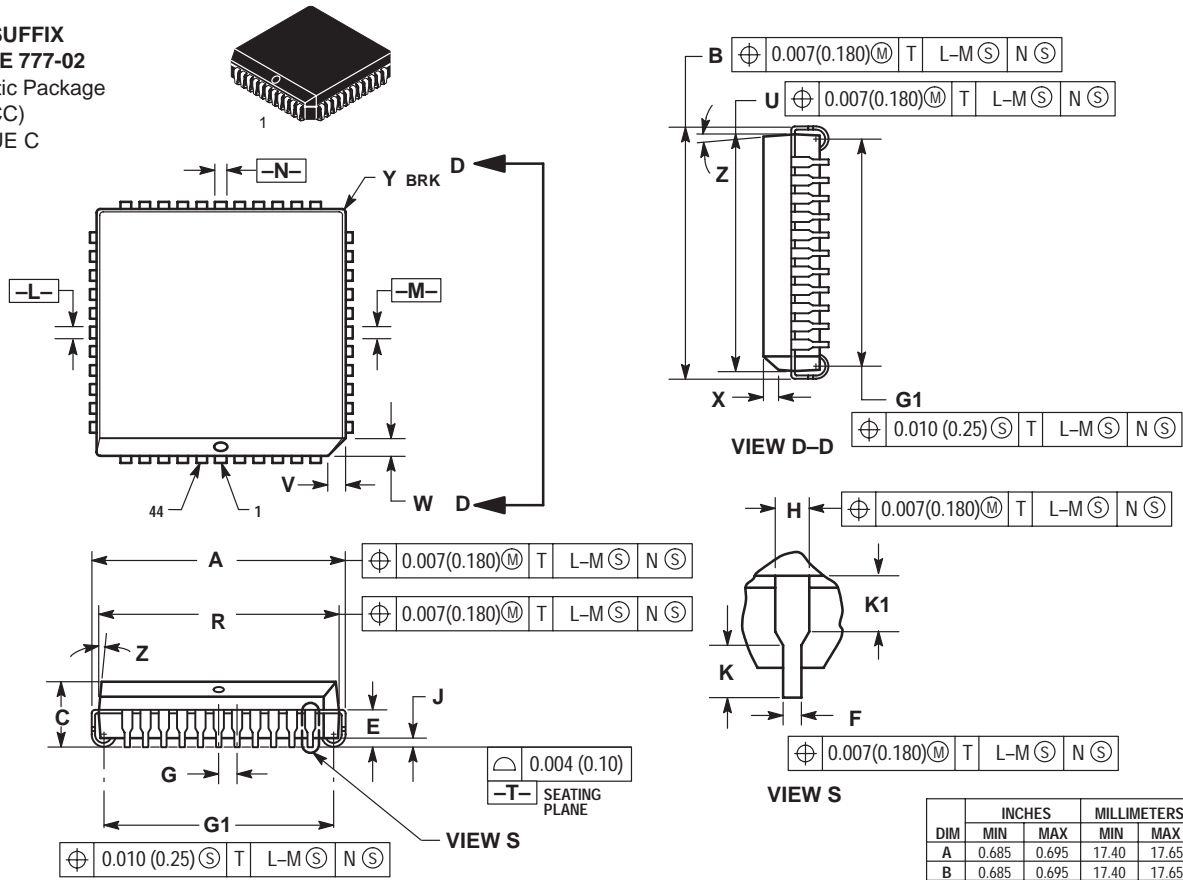

- NOTES:
- DATUMS -L-, -M-, AND -N- ARE DETERMINED WHERE TOP OF LEAD SHOULDER EXITS PLASTIC BODY AT MOLD PARTING LINE.
 - DIMENSION G1, TRUE POSITION TO BE MEASURED AT DATUM -T-, SEATING PLANE.
 - DIMENSIONS R AND U DO NOT INCLUDE MOLD FLASH. ALLOWABLE MOLD FLASH IS 0.010 (0.25) PER SIDE.
 - DIMENSIONING AND TOLERANCING PER ANSI Y14.5M, 1982.
 - CONTROLLING DIMENSION: INCH.

- THE PACKAGE TOP MAY BE SMALLER THAN THE PACKAGE BOTTOM BY UP TO 0.012 (0.300). DIMENSIONS R AND U ARE DETERMINED AT THE OUTERMOST EXTREMES OF THE PLASTIC BODY EXCLUSIVE OF MOLD FLASH, TIE BAR BURRS, GATE BURRS AND INTERLEAD FLASH, BUT INCLUDING ANY MISMATCH BETWEEN THE TOP AND BOTTOM OF THE PLASTIC BODY.
- DIMENSION H DOES NOT INCLUDE DAMBAR PROTRUSION OR INTRUSION. THE DAMBAR PROTRUSION(S) SHALL NOT CAUSE THE H DIMENSION TO BE GREATER THAN 0.037 (0.940). THE DAMBAR INTRUSION(S) SHALL NOT CAUSE THE H DIMENSION TO BE SMALLER THAN 0.025 (0.635).

DIM	INCHES		MILLIMETERS	
	MIN	MAX	MIN	MAX
A	0.685	0.695	17.40	17.65
B	0.685	0.695	17.40	17.65
C	0.165	0.180	4.20	4.57
E	0.090	0.110	2.29	2.79
F	0.013	0.019	0.33	0.48
G	0.050 BSC		1.27 BSC	
H	0.026	0.032	0.66	0.81
J	0.020	---	0.51	---
K	0.025	---	0.64	---
R	0.650	0.656	16.51	16.66
U	0.650	0.656	16.51	16.66
V	0.042	0.048	1.07	1.21
W	0.042	0.048	1.07	1.21
X	0.042	0.056	1.07	1.42
Y	---	0.020	---	0.50
Z	2°	10°	2°	10°
G1	0.610	0.630	15.50	16.00
K1	0.040	---	1.02	---

M SUFFIX
CASE 803C
PRELIMINARY
 Plastic Package

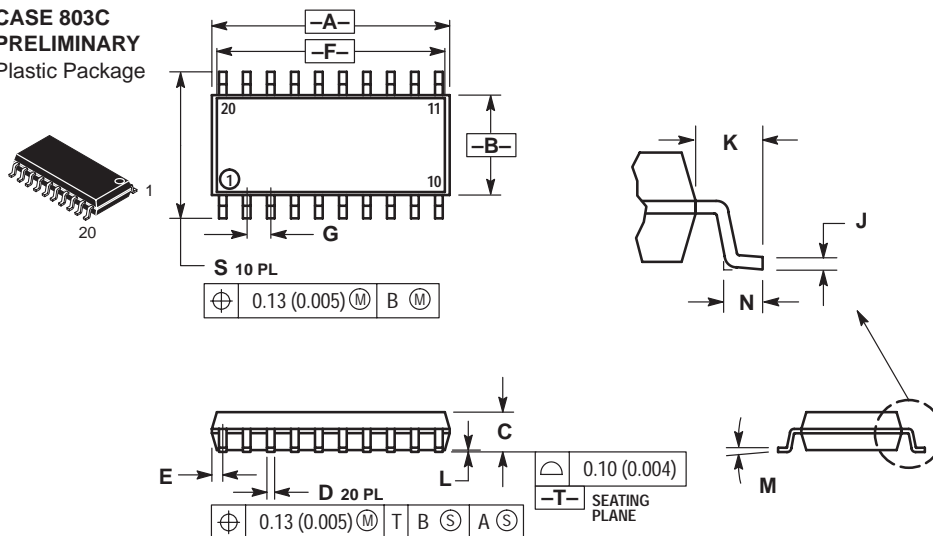

- NOTES:
- DIMENSIONING AND TOLERANCING PER ANSI Y14.5M, 1982.
 - CONTROLLING DIMENSION: MILLIMETER.
 - DIMENSIONS A AND B DO NOT INCLUDE MOLD PROTRUSION.
 - MAXIMUM MOLD PROTRUSION 0.15 (0.008) PER SIDE.
 - DIMENSION D DOES NOT INCLUDE DAMBAR PROTRUSION. ALLOWABLE DAMBAR PROTRUSION SHALL BE 0.13 (0.006) TOTAL IN EXCESS OF THE D DIMENSION AT MAXIMUM MATERIAL CONDITION.

DIM	MILLIMETERS		INCHES	
	MIN	MAX	MIN	MAX
A	12.35	12.80	0.486	0.504
B	5.10	5.45	0.201	0.215
C	1.95	2.05	0.077	0.081
D	0.35	0.50	0.014	0.020
E	---	0.81	---	0.032
F	12.40*		0.488*	
G	1.15	1.39	0.045	0.055
H	0.59	0.81	0.023	0.032
J	0.18	0.27	0.007	0.011
K	1.10	1.50	0.043	0.059
L	0.05	0.20	0.001	0.008
M	0°	10°	0°	10°
N	0.50	0.85	0.020	0.033
S	7.40	8.20	0.291	0.323

*APPROXIMATE

TV SUFFIX
CASE 821C-04
 Plastic Package
 (15-Pin ZIP)
 ISSUE D

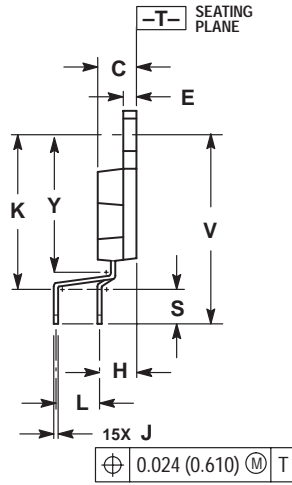
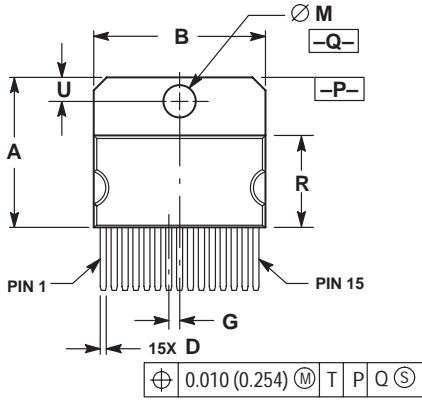
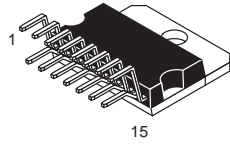

NOTES:

1. DIMENSIONING AND TOLERANCING PER ANSI Y14.5M, 1982.
2. CONTROLLING DIMENSION: INCH.
3. DIMENSION R DOES NOT INCLUDE MOLD FLASH OR PROTRUSIONS.
4. DIMENSION B DOES NOT INCLUDE MOLD FLASH OR PROTRUSIONS.
5. MOLD FLASH OR PROTRUSIONS SHALL NOT EXCEED 0.010 (0.250).
6. DIMENSION D DOES NOT INCLUDE DAMBAR PROTRUSION. ALLOWABLE PROTRUSION SHALL BE 0.003 (0.076) TOTAL IN EXCESS OF THE D DIMENSION, AT MAXIMUM MATERIAL CONDITION.

DIM	INCHES		MILLIMETERS	
	MIN	MAX	MIN	MAX
A	0.684	0.694	17.374	17.627
B	0.784	0.792	19.914	20.116
C	0.173	0.181	4.395	4.597
D	0.024	0.031	0.610	0.787
E	0.058	0.062	1.473	1.574
G	0.050 BSC		1.270 BSC	
H	0.169 BSC		4.293 BSC	
J	0.018	0.024	0.458	0.609
K	0.700	0.710	17.780	18.034
L	0.200 BSC		5.080 BSC	
M	0.148	0.151	3.760	3.835
R	0.416	0.426	10.567	10.820
S	0.157	0.167	3.988	4.242
U	0.105	0.115	2.667	2.921
V	0.868 REF		22.047 REF	
Y	0.625	0.639	15.875	16.231

T SUFFIX
CASE 821D-03
 Plastic Package
 ISSUE C

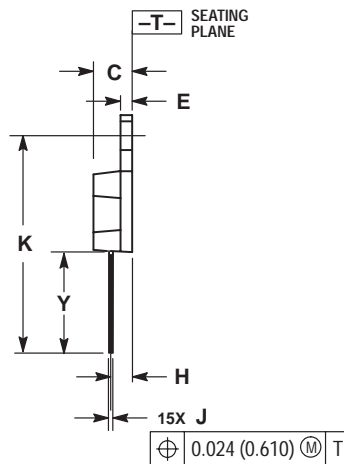
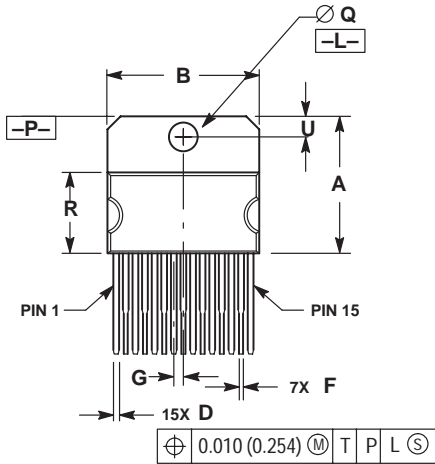
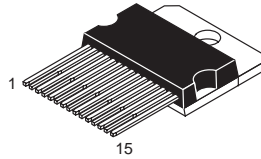

NOTES:

1. DIMENSIONING AND TOLERANCING PER ANSI Y14.5M, 1982.
2. CONTROLLING DIMENSION: INCH.
3. DIMENSION R DOES NOT INCLUDE MOLD FLASH OR PROTRUSIONS.
4. DIMENSION B DOES NOT INCLUDE MOLD FLASH OR PROTRUSIONS.
5. MOLD FLASH OR PROTRUSIONS SHALL NOT EXCEED 0.010 (0.250).
6. DELETED
7. DIMENSION D DOES NOT INCLUDE DAMBAR PROTRUSION. ALLOWABLE PROTRUSION SHALL BE 0.003 (0.076) TOTAL IN EXCESS OF THE D DIMENSION, AT MAXIMUM MATERIAL CONDITION.

DIM	INCHES		MILLIMETERS	
	MIN	MAX	MIN	MAX
A	0.681	0.694	17.298	17.627
B	0.784	0.792	19.914	20.116
C	0.173	0.181	4.395	4.597
D	0.024	0.031	0.610	0.787
E	0.058	0.062	1.473	1.574
F	0.016	0.023	0.407	0.584
G	0.050 BSC		1.270 BSC	
H	0.110 BSC		2.794 BSC	
J	0.018	0.024	0.458	0.609
K	1.078	1.086	27.382	27.584
Q	0.148	0.151	3.760	3.835
R	0.416	0.426	10.567	10.820
U	0.110 BSC		2.794 BSC	
Y	0.503 REF		12.776 REF	

FTB SUFFIX
CASE 824D-01
 Plastic Package
 (TQFP-44)
 ISSUE O

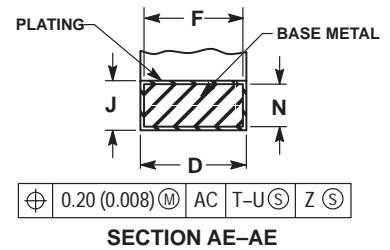
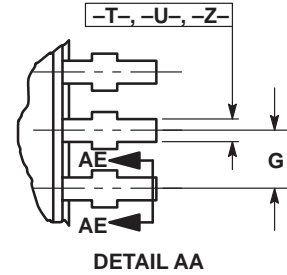
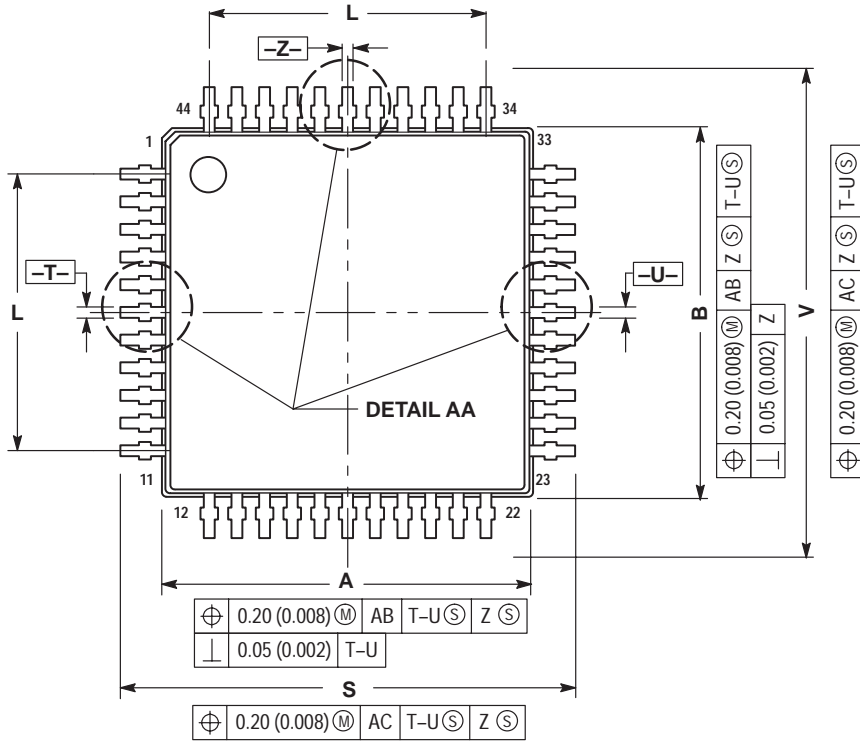
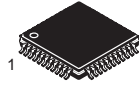

- NOTES:
- DIMENSIONING AND TOLERANCING PER ANSI Y14.5M, 1982.
 - CONTROLLING DIMENSION: MILLIMETER.
 - DATUM PLANE -AB- IS LOCATED AT BOTTOM OF LEAD AND IS COINCIDENT WITH THE LEAD WHERE THE LEAD EXITS THE PLASTIC BODY AT THE BOTTOM OF THE PARTING LINE.
 - DATUMS -T-, -U- AND -Z- TO BE DETERMINED AT DATUM PLANE -AB-.
 - DIMENSIONS S AND V TO BE DETERMINED AT SEATING PLANE -AC-.
 - DIMENSIONS A AND B DO NOT INCLUDE MOLD PROTRUSION. ALLOWABLE PROTRUSION IS 0.25 (0.010) PER SIDE. DIMENSIONS A AND B DO INCLUDE MOLD MISMATCH AND ARE DETERMINED AT DATUM PLANE -AB-.
 - DIMENSION D DOES NOT INCLUDE DAMBAR PROTRUSION. DAMBAR PROTRUSION SHALL NOT CAUSE THE D DIMENSION TO EXCEED 0.530 (0.021).

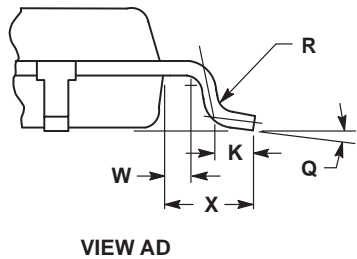
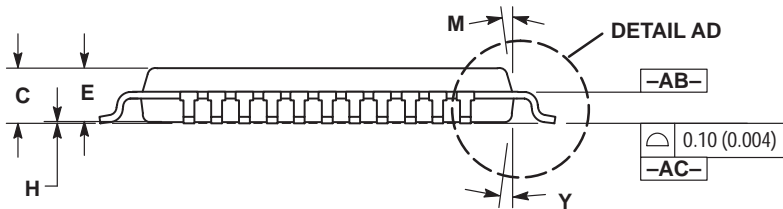

DIM	MILLIMETERS		INCHES	
	MIN	MAX	MIN	MAX
A	9.950	10.050	0.392	0.396
B	9.950	10.050	0.392	0.396
C	1.400	1.600	0.055	0.063
D	0.300	0.450	0.012	0.018
E	1.350	1.450	0.053	0.057
F	0.300	0.400	0.012	0.016
G	0.800 BSC		0.031 BSC	
H	0.050	0.150	0.002	0.006
J	0.090	0.200	0.004	0.008
K	0.450	0.550	0.018	0.022
L	8.000 BSC		0.315 BSC	
M	12° REF		12° REF	
N	0.090	0.160	0.004	0.006
Q	1°	5°	1°	5°
R	0.100	0.200	0.004	0.008
S	11.900	12.100	0.469	0.476
V	11.900	12.100	0.469	0.476
W	0.200 REF		0.008 REF	
X	1.000 REF		0.039 REF	
Y	12° REF		12° REF	

FB SUFFIX
CASE 824E-02
 Plastic Package
 (QFP)
 ISSUE A

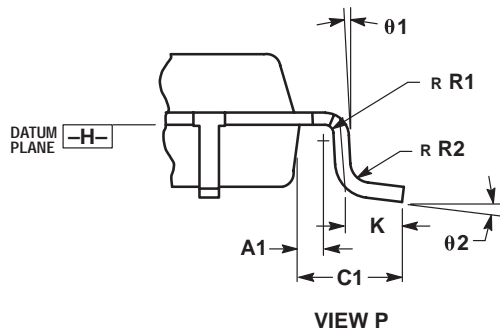
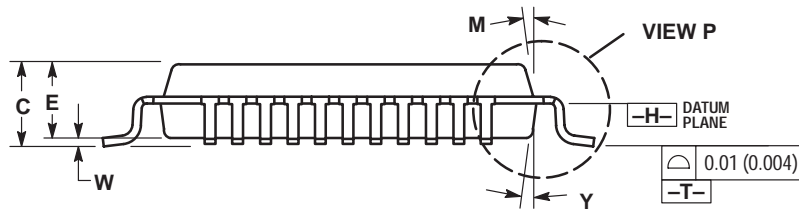
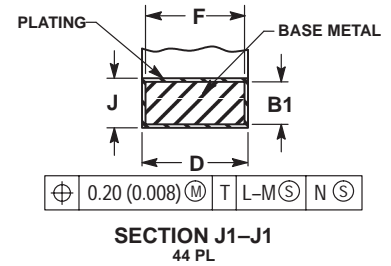
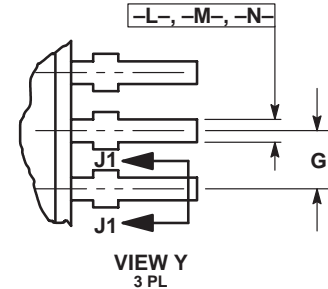
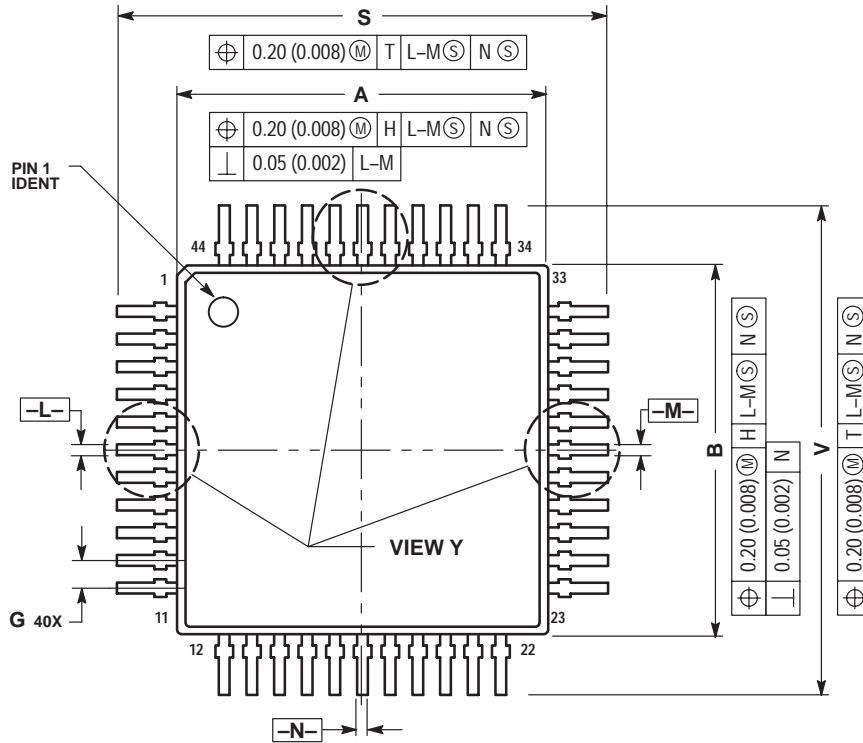
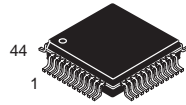

NOTES:

- DIMENSIONING AND TOLERANCING PER ANSI Y14.5M, 1982.
- CONTROLLING DIMENSION: MILLIMETER.
- DATUM PLANE -H- IS LOCATED AT BOTTOM OF LEAD AND IS COINCIDENT WITH THE LEAD WHERE THE LEAD EXITS THE PLASTIC BODY AT THE BOTTOM OF THE PARTING LINE.
- DATUMS -L-, -M- AND -N- TO BE DETERMINED AT DATUM PLANE -H-.
- DIMENSIONS S AND V TO BE DETERMINED AT SEATING PLANE -T-.
- DIMENSIONS A AND B DO NOT INCLUDE MOLD PROTRUSION. ALLOWABLE PROTRUSION IS 0.25 (0.010) PER SIDE. DIMENSIONS A AND B DO INCLUDE MOLD MISMATCH AND ARE DETERMINED AT DATUM PLANE -H-.
- DIMENSION D DOES NOT INCLUDE DAMBAR PROTRUSION. DAMBAR PROTRUSION SHALL NOT CAUSE THE D DIMENSION TO EXCEED 0.530 (0.021).

DIM	MILLIMETERS		INCHES	
	MIN	MAX	MIN	MAX
A	9.90	10.10	0.390	0.398
B	9.90	10.10	0.390	0.398
C	2.00	2.21	0.079	0.087
D	0.30	0.45	0.0118	0.0177
E	2.00	2.10	0.079	0.083
F	0.30	0.40	0.012	0.016
G	0.80 BSC		0.031 BSC	
J	0.13	0.23	0.005	0.009
K	0.65	0.95	0.026	0.037
M	5° 10°		5° 10°	
S	12.95	13.45	0.510	0.530
V	12.95	13.45	0.510	0.530
W	0.000	0.210	0.000	0.008
Y	5° 10°		5° 10°	
A1	0.450 REF		0.018 REF	
B1	0.130	0.170	0.005	0.007
C1	1.600 REF		0.063 REF	
R1	0.130	0.300	0.005	0.012
R2	0.130	0.300	0.005	0.012
theta 1	5° 10°		5° 10°	
theta 2	0° 7°		0° 7°	

FB SUFFIX
CASE 840F-01
 Plastic Package
 ISSUE O

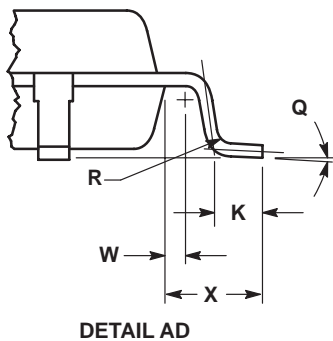
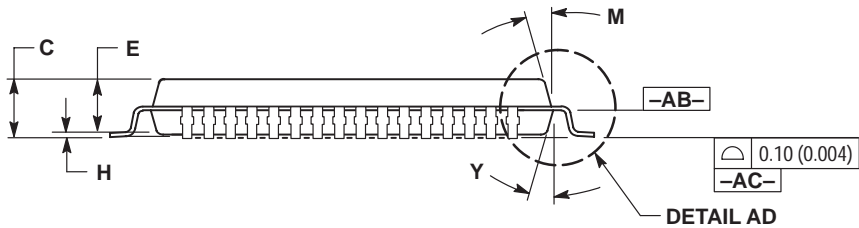
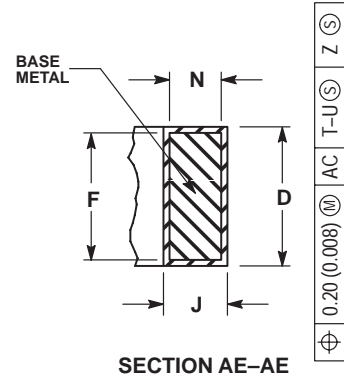
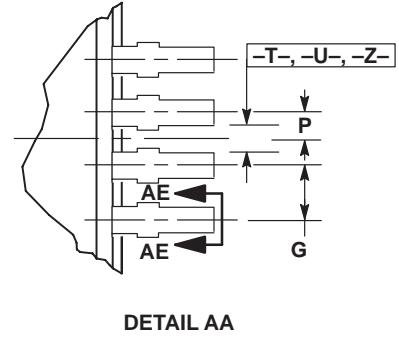
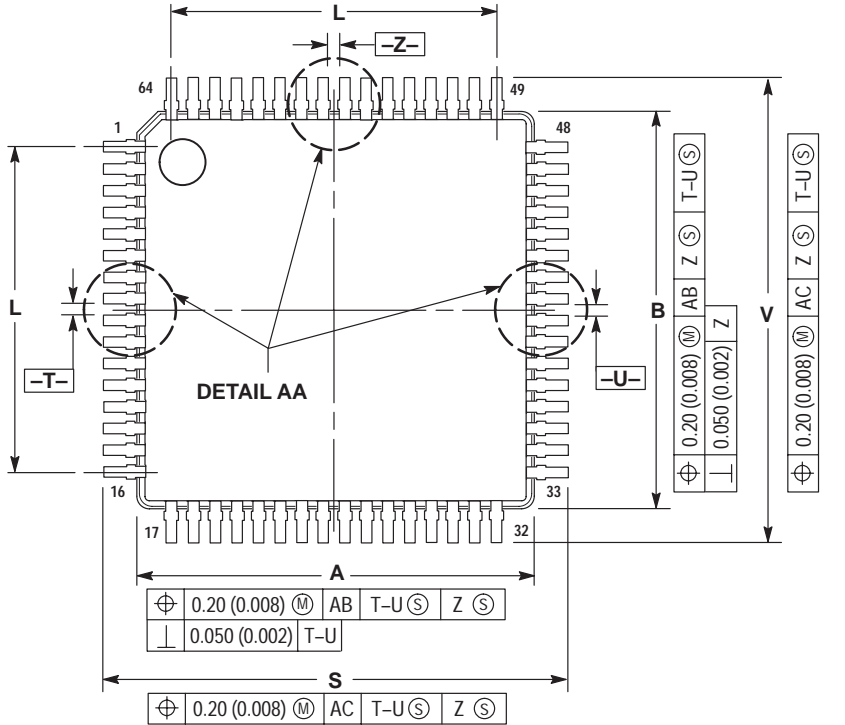
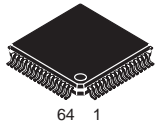

- NOTES:**
1. DIMENSIONING AND TOLERANCING PER ANSI Y14.5M, 1982.
 2. CONTROLLING DIMENSION: MILLIMETER.
 3. DATUM PLANE -AB- IS LOCATED AT BOTTOM OF LEAD AND IS COINCIDENT WITH THE LEAD WHERE THE LEAD EXITS THE PLASTIC BODY AT THE BOTTOM OF THE PARTING LINE.
 4. DATUMS -T-, -U- AND -Z- TO BE DETERMINED AT DATUM PLANE -AC-.
 5. DIMENSIONS S AND V TO BE DETERMINED AT SEATING PLANE -AC-.
 6. DIMENSIONS A AND B DO NOT INCLUDE MOLD PROTRUSION. ALLOWABLE PROTRUSION IS 0.25 (0.010) PER SIDE. DIMENSIONS A AND B DO INCLUDE MOLD MISMATCH AND ARE DETERMINED AT DATUM PLANE -AB-.
 7. DIMENSION D DOES NOT INCLUDE DAMBAR PROTRUSION. DAMBAR PROTRUSION SHALL NOT CAUSE THE D DIMENSION TO EXCEED 0.350 (0.014).

DIM	MILLIMETERS		INCHES	
	MIN	MAX	MIN	MAX
A	9.950	10.050	0.392	0.396
B	9.950	10.050	0.392	0.396
C	1.400	1.600	0.055	0.063
D	0.170	0.270	0.007	0.011
E	1.350	1.450	0.053	0.057
F	0.170	0.230	0.007	0.009
G	0.500 BSC		0.020 BSC	
H	0.050	0.150	0.002	0.006
J	0.090	0.200	0.004	0.008
K	0.450	0.550	0.018	0.022
L	7.500 BSC		0.295 BSC	
M	12° REF		12° REF	
N	0.090	0.160	0.004	0.006
P	0.250 BSC		0.010 BSC	
Q	1°	5°	1°	5°
R	0.100	0.200	0.004	0.008
S	11.900	12.100	0.469	0.476
V	11.900	12.100	0.469	0.476
W	0.200 REF		0.008 REF	
X	1.000 REF		0.039 REF	
Y	12° REF		12° REF	

DM SUFFIX
CASE 846A-02
 Plastic Package
 (Micro-8)
 ISSUE C

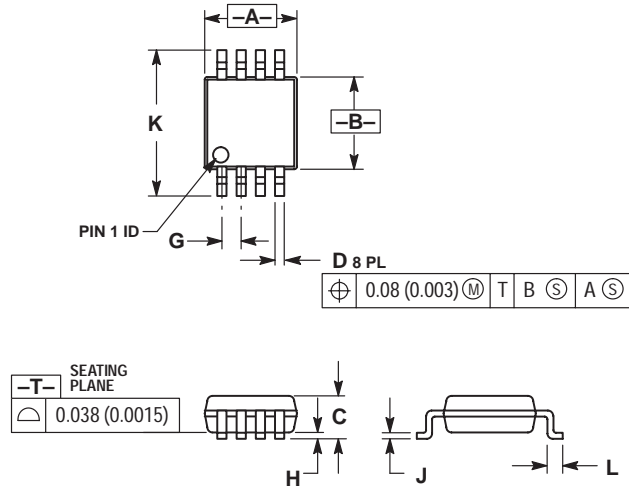

NOTES:

1. DIMENSIONING AND TOLERANCING PER ANSI Y14.5M, 1982.
2. CONTROLLING DIMENSION: MILLIMETER.
3. DIMENSION A DOES NOT INCLUDE MOLD FLASH, PROTRUSIONS OR GATE BURRS. MOLD FLASH, PROTRUSIONS OR GATE BURRS SHALL NOT EXCEED 0.15 (0.006) PER SIDE.
4. DIMENSION B DOES NOT INCLUDE INTERLEAD FLASH OR PROTRUSION. INTERLEAD FLASH OR PROTRUSION SHALL NOT EXCEED 0.25 (0.010) PER SIDE.

DIM	MILLIMETERS		INCHES	
	MIN	MAX	MIN	MAX
A	2.90	3.10	0.114	0.122
B	2.90	3.10	0.114	0.122
C	---	1.10	---	0.043
D	0.25	0.40	0.010	0.016
G	0.65 BSC		0.026 BSC	
H	0.05	0.15	0.002	0.006
J	0.13	0.23	0.005	0.009
K	4.75	5.05	0.187	0.199
L	0.40	0.70	0.016	0.028

FB SUFFIX
CASE 848B-04
 Plastic Package
 (TQFP-52)
 ISSUE C

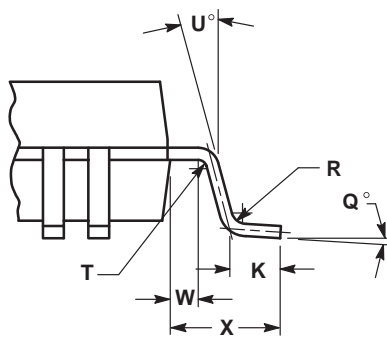
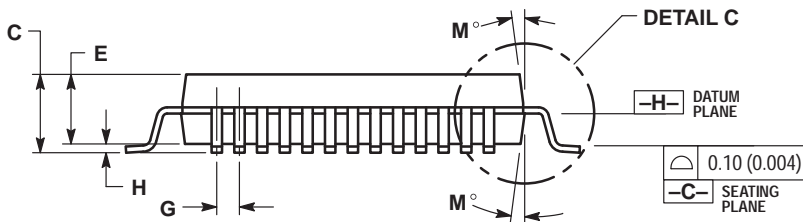
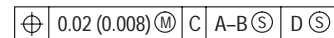
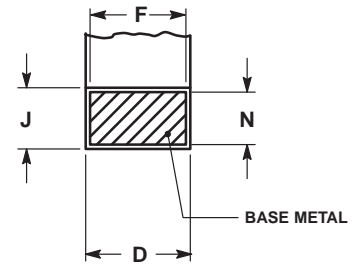
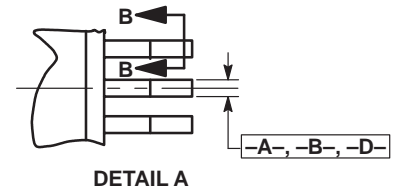
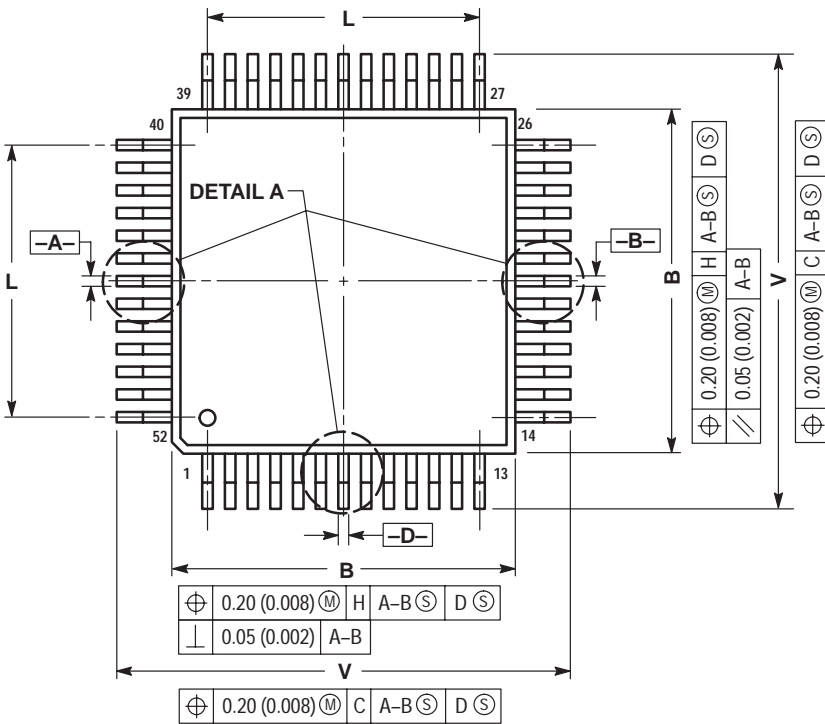
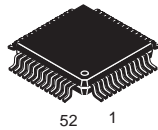

NOTES:

- DIMENSIONING AND TOLERANCING PER ANSI Y14.5M, 1982.
- CONTROLLING DIMENSION: MILLIMETER.
- DATUM PLANE -H- IS LOCATED AT BOTTOM OF LEAD AND IS COINCIDENT WITH THE LEAD WHERE THE LEAD EXITS THE PLASTIC BODY AT THE BOTTOM OF THE PARTING LINE.
- DATUMS -A-, -B- AND -D- TO BE DETERMINED AT DATUM PLANE -H-.
- DIMENSIONS S AND V TO BE DETERMINED AT SEATING PLANE -C-.
- DIMENSIONS A AND B DO NOT INCLUDE MOLD PROTRUSION. ALLOWABLE PROTRUSION IS 0.25 (0.010) PER SIDE. DIMENSIONS A AND B DO INCLUDE MOLD MISMATCH AND ARE DETERMINED AT DATUM PLANE -H-.
- DIMENSION D DOES NOT INCLUDE DAMBAR PROTRUSION. ALLOWABLE DAMBAR PROTRUSION SHALL BE 0.08 (0.003) TOTAL IN EXCESS OF THE D DIMENSION AT MAXIMUM MATERIAL CONDITION. DAMBAR CANNOT BE LOCATED ON THE LOWER RADIUS OR THE FOOT.

DIM	MILLIMETERS		INCHES	
	MIN	MAX	MIN	MAX
A	9.90	10.10	0.390	0.398
B	9.90	10.10	0.390	0.398
C	2.10	2.45	0.083	0.096
D	0.22	0.38	0.009	0.015
E	2.00	2.10	0.079	0.083
F	0.22	0.33	0.009	0.013
G	0.65 BSC		0.026 BSC	
H	---	0.25	---	0.010
J	0.13	0.23	0.005	0.009
K	0.65	0.95	0.026	0.037
L	7.80 REF		0.307 REF	
M	5°	10°	5°	10°
N	0.13	0.17	0.005	0.007
Q	0°	7°	0°	7°
R	0.13	0.30	0.005	0.012
S	12.95	13.45	0.510	0.530
T	0.13	---	0.005	---
U	0°	---	0°	---
V	12.95	13.45	0.510	0.530
W	0.35	0.45	0.014	0.018
X	1.6 REF		0.063 REF	

FB SUFFIX
CASE 848D-03
 Plastic Package
 ISSUE C

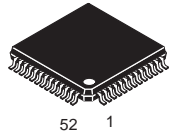

52 1

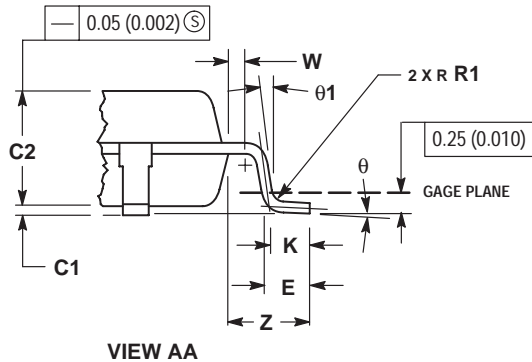
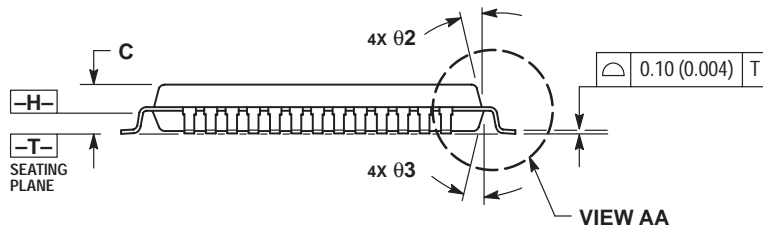
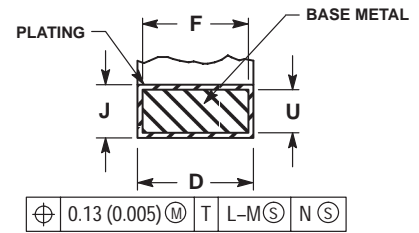
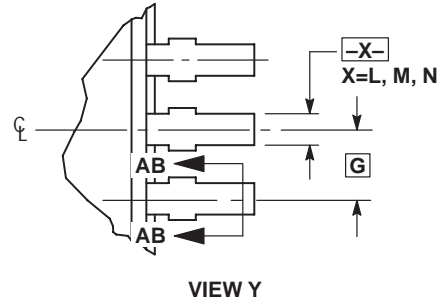
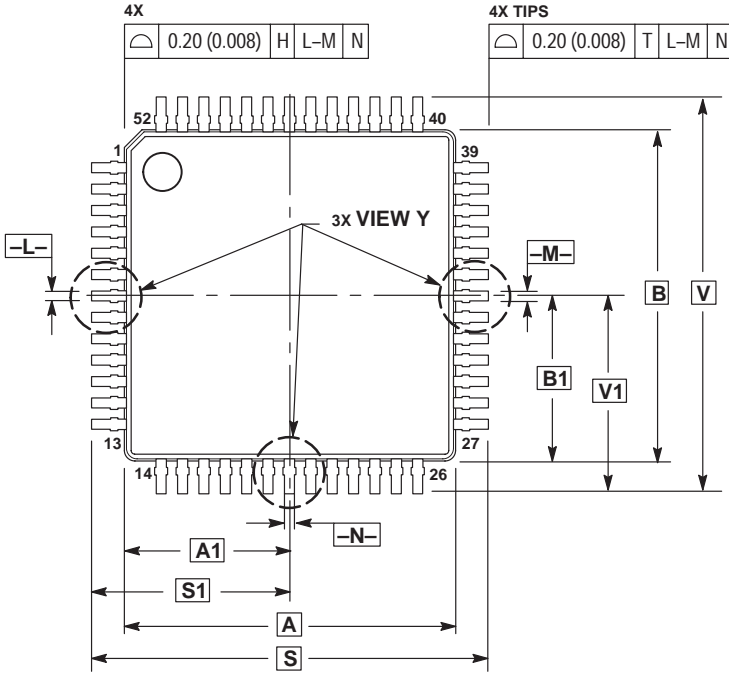

- NOTES:
1. DIMENSIONING AND TOLERANCING PER ANSI Y14.5M, 1982.
 2. CONTROLLING DIMENSION: MILLIMETER.
 3. DATUM PLANE -H- IS LOCATED AT BOTTOM OF LEAD AND IS COINCIDENT WITH THE LEAD WHERE THE LEAD EXITS THE PLASTIC BODY AT THE BOTTOM OF THE PARTING LINE.
 4. DATUMS -L-, -M- AND -N- TO BE DETERMINED AT DATUM PLANE -H-.
 5. DIMENSIONS S AND V TO BE DETERMINED AT SEATING PLANE -T-.
 6. DIMENSIONS A AND B DO NOT INCLUDE MOLD PROTRUSION. ALLOWABLE PROTRUSION IS 0.25 (0.010) PER SIDE. DIMENSIONS A AND B DO NOT INCLUDE MOLD MISMATCH AND ARE DETERMINED AT DATUM PLANE -H-.
 7. DIMENSION D DOES NOT INCLUDE DAMBAR PROTRUSION. DAMBAR PROTRUSION SHALL NOT CAUSE THE LEAD WIDTH TO EXCEED 0.46 (0.018). MINIMUM SPACE BETWEEN PROTRUSION AND ADJACENT LEAD OR PROTRUSION 0.07 (0.003).

DIM	MILLIMETERS		INCHES	
	MIN	MAX	MIN	MAX
A	10.00 BSC	0.394 BSC		
A1	5.00 BSC	0.197 BSC		
B	10.00 BSC	0.394 BSC		
B1	5.00 BSC	0.197 BSC		
C	---	1.70	---	0.067
C1	0.05	0.20	0.002	0.008
C2	1.30	1.50	0.051	0.059
D	0.20	0.40	0.008	0.016
E	0.45	0.75	0.018	0.030
F	0.22	0.35	0.009	0.014
G	0.65 BSC	0.026 BSC		
J	0.07	0.20	0.003	0.008
K	0.50 REF	0.020 REF		
R1	0.08	0.20	0.003	0.008
S	12.00 BSC	0.472 BSC		
S1	6.00 BSC	0.236 BSC		
U	0.09	0.16	0.004	0.006
V	12.00 BSC	0.472 BSC		
V1	6.00 BSC	0.236 BSC		
W	0.20 REF	0.008 REF		
Z	1.00 REF	0.039 REF		
θ	0°	7°	0°	7°
$\theta 1$	0°	---	0°	---
$\theta 2$	12° REF	12° REF		
$\theta 3$	5°	13°	5°	13°

B SUFFIX
CASE 858-01
 Plastic Package
 ISSUE O

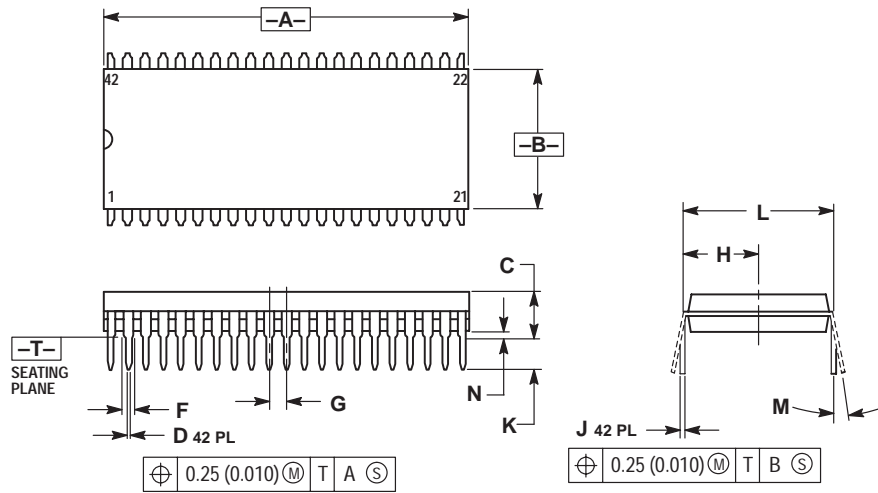
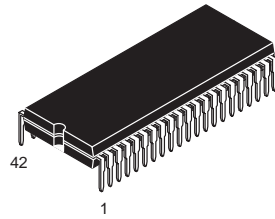

NOTES:

1. DIMENSIONING AND TOLERANCING PER ANSI Y14.5M, 1982.
2. CONTROLLING DIMENSION: INCH.
3. DIMENSION L TO CENTER OF LEAD WHEN FORMED PARALLEL.
4. DIMENSIONS A AND B DO NOT INCLUDE MOLD FLASH. MAXIMUM MOLD FLASH 0.25 (0.010).

DIM	INCHES		MILLIMETERS	
	MIN	MAX	MIN	MAX
A	1.435	1.465	36.45	37.21
B	0.540	0.560	13.72	14.22
C	0.155	0.200	3.94	5.08
D	0.014	0.022	0.36	0.56
F	0.032	0.046	0.81	1.17
G	0.070 BSC		1.778 BSC	
H	0.300 BSC		7.62 BSC	
J	0.008	0.015	0.20	0.38
K	0.115	0.135	2.92	3.43
L	0.600 BSC		15.24 BSC	
M	0°	15°	0°	15°
N	0.020	0.040	0.51	1.02

B SUFFIX
CASE 859-01
 Plastic Package
 (SDIP)
 ISSUE O

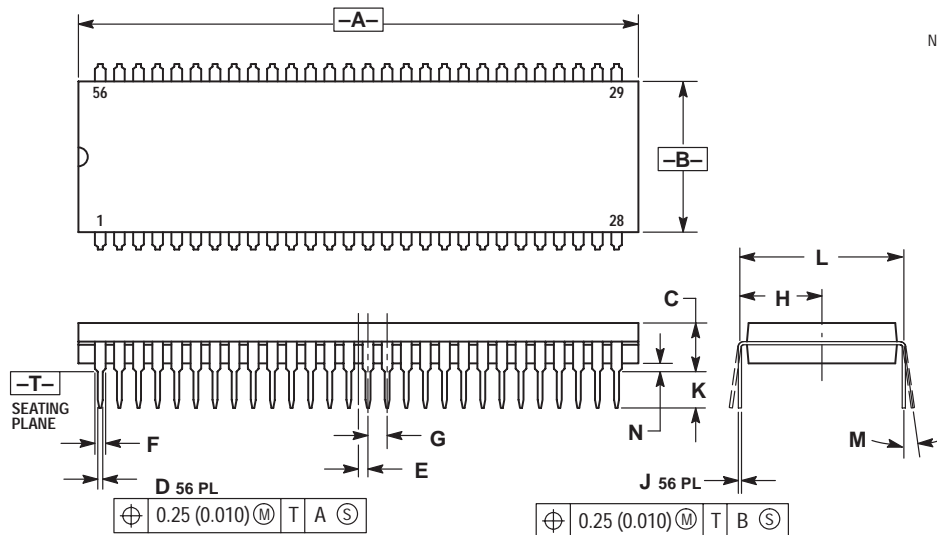
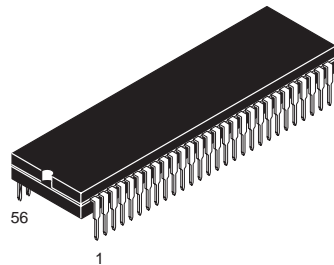

NOTES:

1. DIMENSIONING AND TOLERANCING PER ANSI Y14.5M, 1982.
2. CONTROLLING DIMENSION: INCH.
3. DIMENSION L TO CENTER OF LEAD WHEN FORMED PARALLEL.
4. DIMENSIONS A AND B DO NOT INCLUDE MOLD FLASH. MAXIMUM MOLD FLASH 0.25 (0.010)

DIM	INCHES		MILLIMETERS	
	MIN	MAX	MIN	MAX
A	2.035	2.065	51.69	52.45
B	0.540	0.560	13.72	14.22
C	0.155	0.200	3.94	5.08
D	0.014	0.022	0.36	0.56
E	0.035 BSC		0.89 BSC	
F	0.032	0.046	0.81	1.17
G	0.070 BSC		1.778 BSC	
H	0.300 BSC		7.62 BSC	
J	0.008	0.015	0.20	0.38
K	0.115	0.135	2.92	3.43
L	0.600 BSC		15.24 BSC	
M	0°	15°	0°	15°
N	0.020	0.040	0.51	1.02

FB, FTB SUFFIX
CASE 873-01
 Plastic Package
 (TQFP-32)
 ISSUE A

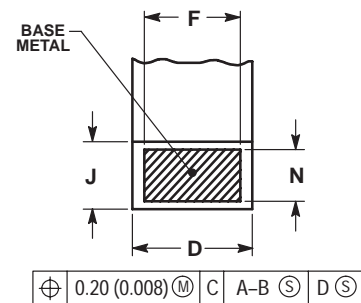
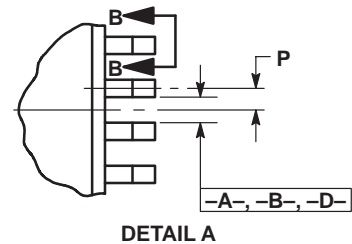
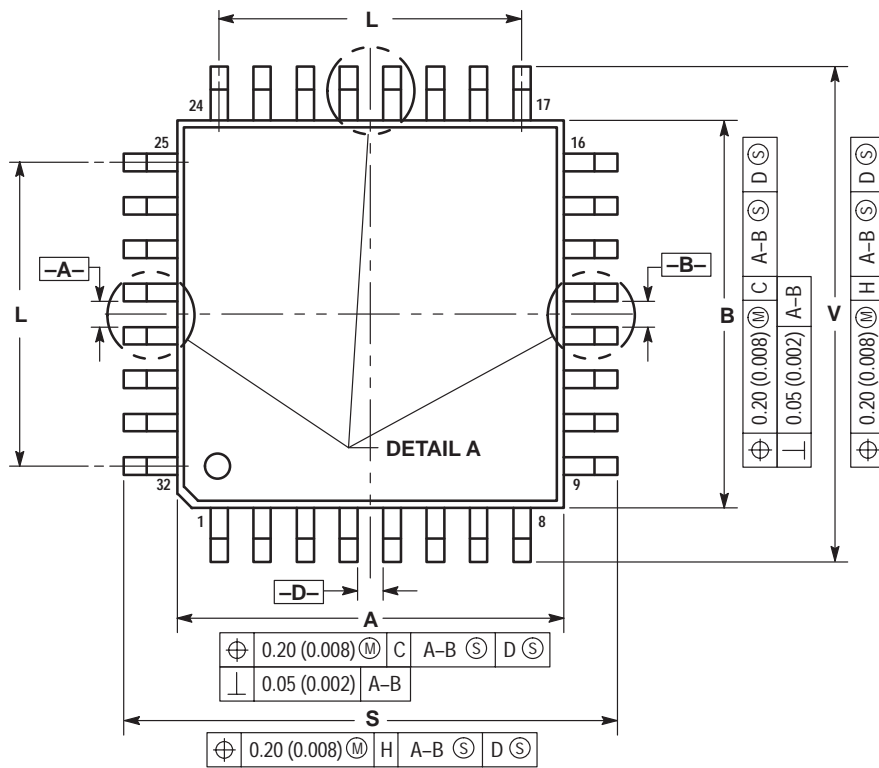
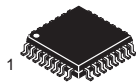

SECTION B-B
 VIEW ROTATED 90° CLOCKWISE

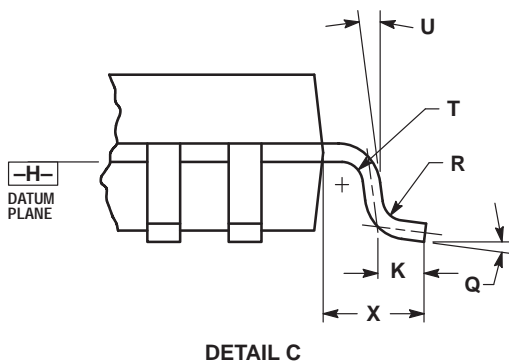
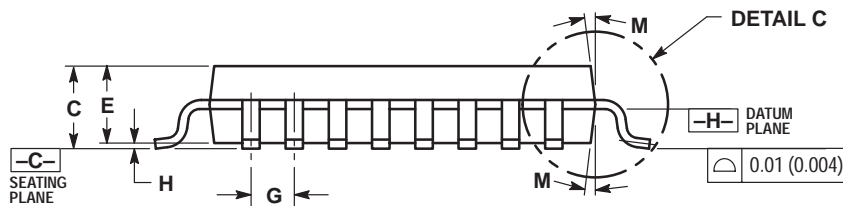

NOTES:

- DIMENSION AND TOLERANCING PER ANSI Y14.5M, 1982.
- CONTROLLING DIMENSION: MILLIMETER.
- DATUM PLANE -H- IS LOCATED AT BOTTOM OF LEAD AND IS COINCIDENT WITH THE LEAD WHERE THE LEAD EXITS THE PLASTIC BODY AT THE BOTTOM OF THE PARTING LINE.
- DATUMS -A-, -B- AND -D- TO BE DETERMINED AT DATUM PLANE -H-.
- DIMENSIONS S AND V TO BE DETERMINED AT SEATING PLANE -C-.
- DIMENSIONS A AND B DO NOT INCLUDE MOLD PROTRUSION. ALLOWABLE PROTRUSION IS 0.25 (0.010) PER SIDE. DIMENSIONS A AND B DO INCLUDE MOLD MISMATCH AND ARE DETERMINED AT DATUM PLANE -H-.
- DIMENSION D DOES NOT INCLUDE DAMBAR PROTRUSION. ALLOWABLE DAMBAR PROTRUSION SHALL BE 0.08 (0.003) TOTAL IN EXCESS OF THE D DIMENSION AT MAXIMUM MATERIAL CONDITION. DAMBAR CANNOT BE LOCATED ON THE LOWER RADIUS OR THE FOOT.

DIM	MILLIMETERS		INCHES	
	MIN	MAX	MIN	MAX
A	6.95	7.10	0.274	0.280
B	6.95	7.10	0.274	0.280
C	1.40	1.60	0.055	0.063
D	0.273	0.373	0.010	0.015
E	1.30	1.50	0.051	0.059
F	0.273	---	0.010	---
G	0.80	BSC	0.031	BSC
H	---	0.20	---	0.008
J	0.119	0.197	0.005	0.008
K	0.33	0.57	0.013	0.022
L	5.6	REF	0.220	REF
M	6°	8°	6°	8°
N	0.119	0.135	0.005	0.005
P	0.40	BSC	0.016	BSC
Q	5°	10°	5°	10°
R	0.15	0.25	0.006	0.010
S	8.85	9.15	0.348	0.360
T	0.15	0.25	0.006	0.010
U	5°	11°	5°	11°
V	8.85	9.15	0.348	0.360
X	1.00	REF	0.039	REF

T SUFFIX
CASE 894-03
 Plastic Package
 (23-Pin SZIP)
 ISSUE B

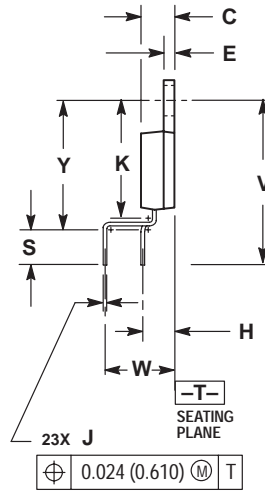
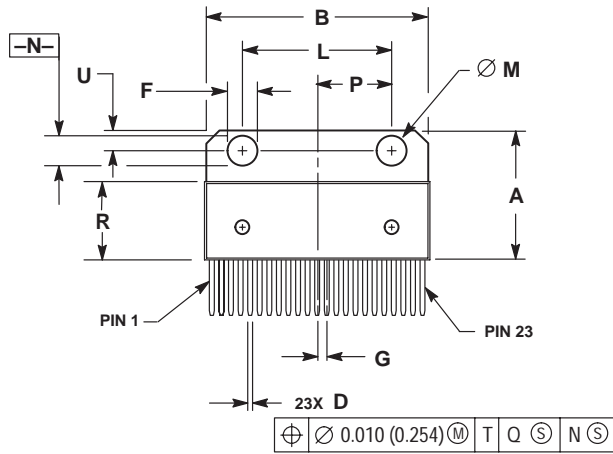
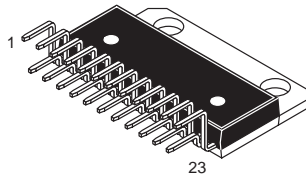

NOTES:

1. DIMENSIONING AND TOLERANCING PER ANSI Y14.5M, 1982.
2. CONTROLLING DIMENSION: INCH.
3. DIMENSION R DOES NOT INCLUDE MOLD FLASH OR PROTRUSIONS.
4. DIMENSION B DOES NOT INCLUDE MOLD FLASH OR PROTRUSIONS.
5. MOLD FLASH OR PROTRUSIONS SHALL NOT EXCEED 0.010 (0.250).
6. DIMENSION D DOES NOT INCLUDE DAMBAR PROTRUSION. ALLOWABLE PROTRUSION SHALL BE 0.003 (0.076) TOTAL IN EXCESS OF THE D DIMENSION AT MAXIMUM MATERIAL CONDITION.

DIM	INCHES		MILLIMETERS	
	MIN	MAX	MIN	MAX
A	0.684	0.694	17.374	17.627
B	1.183	1.193	30.048	30.302
C	0.175	0.179	4.445	4.547
D	0.026	0.031	0.660	0.787
E	0.058	0.062	1.473	1.574
F	0.165	0.175	4.191	4.445
G	0.050 BSC		1.270 BSC	
H	0.169 BSC		4.293 BSC	
J	0.014	0.020	0.356	0.508
K	0.625	0.639	15.875	16.231
L	0.770	0.790	19.558	20.066
M	0.148	0.152	3.760	3.861
N	0.148	0.152	3.760	3.861
P	0.390 BSC		9.906 BSC	
R	0.416	0.424	10.566	10.770
S	0.157	0.167	3.988	4.242
U	0.105	0.115	2.667	2.921
V	0.868 REF		22.047 REF	
W	0.200 BSC		5.080 BSC	
Y	0.700	0.710	17.780	18.034

FTA SUFFIX
CASE 932-02
 Plastic Package
 (TQFP-48)
 ISSUE D

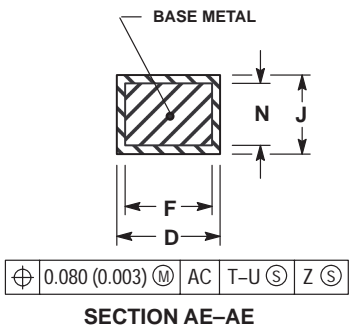
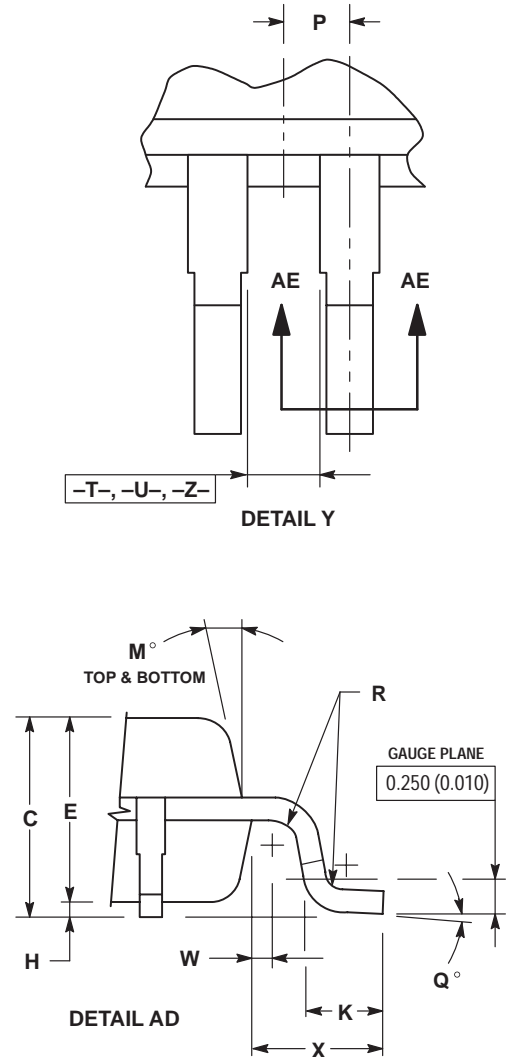
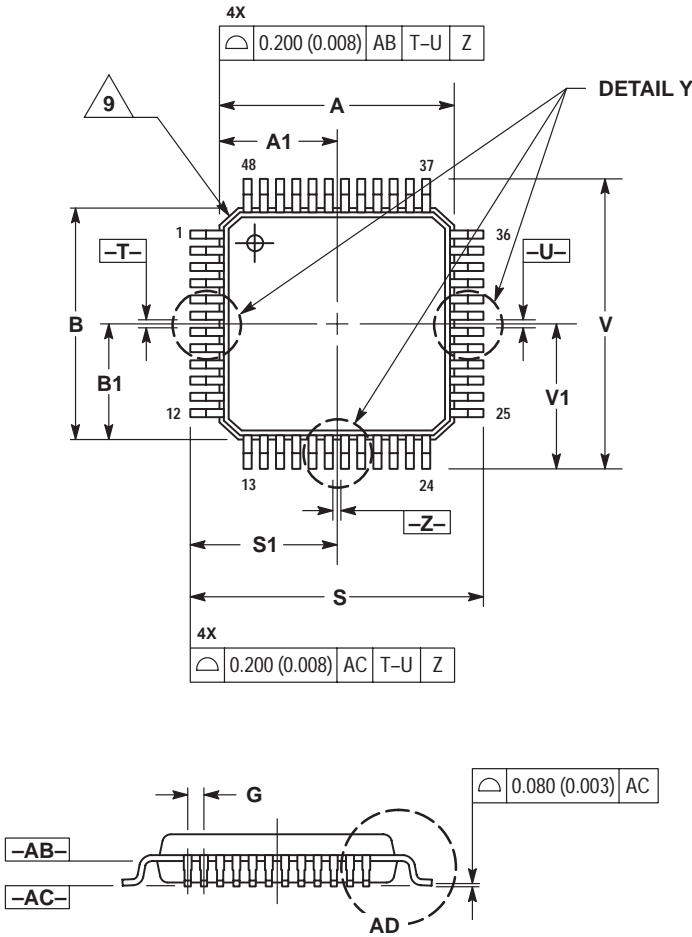
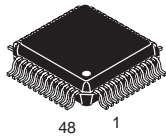

- NOTES:
1. DIMENSIONING AND TOLERANCING PER ANSI Y14.5M, 1982.
 2. CONTROLLING DIMENSION: MILLIMETER.
 3. DATUM PLANE -AB- IS LOCATED AT BOTTOM OF LEAD AND IS COINCIDENT WITH THE LEAD WHERE THE LEAD EXITS THE PLASTIC BODY AT THE BOTTOM OF THE PARTING LINE.
 4. DATUMS -T-, -U-, AND -Z- TO BE DETERMINED AT DATUM PLANE -AB-.
 5. DIMENSIONS S AND V TO BE DETERMINED AT SEATING PLANE -AC-.
 6. DIMENSIONS A AND B DO NOT INCLUDE MOLD PROTRUSION. ALLOWABLE PROTRUSION IS 0.250 (0.010) PER SIDE. DIMENSIONS A AND B DO NOT INCLUDE MOLD MISMATCH AND ARE DETERMINED AT DATUM PLANE -AB-.
 7. DIMENSION D DOES NOT INCLUDE DAMBAR PROTRUSION. DAMBAR PROTRUSION SHALL NOT CAUSE THE D DIMENSION TO EXCEED 0.350 (0.014).
 8. MINIMUM SOLDER PLATE THICKNESS SHALL BE 0.0076 (0.0003).
 9. EXACT SHAPE OF EACH CORNER IS OPTIONAL.

DIM	MILLIMETERS		INCHES	
	MIN	MAX	MIN	MAX
A	7.000 BSC		0.276 BSC	
A1	3.500 BSC		0.138 BSC	
B	7.000 BSC		0.276 BSC	
B1	3.500 BSC		0.138 BSC	
C	1.400	1.600	0.055	0.063
D	0.170	0.270	0.007	0.011
E	1.350	1.450	0.053	0.057
F	0.170	0.230	0.007	0.009
G	0.500 BASIC		0.020 BASIC	
H	0.050	0.150	0.002	0.006
J	0.090	0.200	0.004	0.008
K	0.500	0.700	0.020	0.028
M	12° REF		12° REF	
N	0.090	0.160	0.004	0.006
P	0.250 BASIC		0.010 BASIC	
Q	1°	5°	1°	5°
R	0.150	0.250	0.006	0.010
S	9.000 BSC		0.354 BSC	
S1	4.500 BSC		0.177 BSC	
V	9.000 BSC		0.354 BSC	
V1	4.500 BSC		0.177 BSC	
W	0.200 REF		0.008 REF	
X	1.000 REF		0.039 REF	

D2T SUFFIX
CASE 936-03
 Plastic Package
 ISSUE B

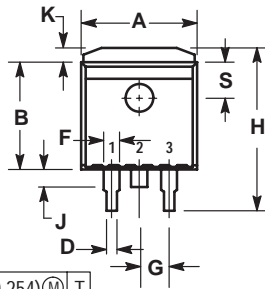
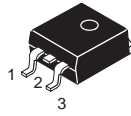

⊕ 0.010 (0.254) Ⓜ T

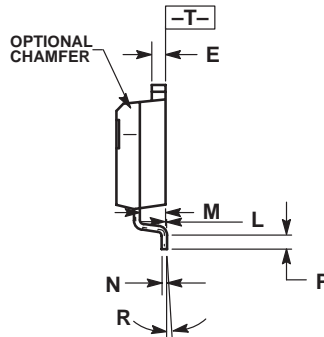
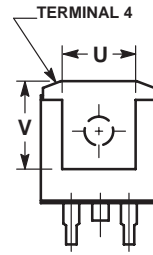
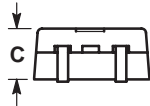

- NOTES:
1. DIMENSIONING AND TOLERANCING PER ANSI Y14.5M, 1982.
 2. CONTROLLING DIMENSION: INCH.
 3. TAB CONTOUR OPTIONAL WITHIN DIMENSIONS A AND K.
 4. DIMENSIONS U AND V ESTABLISH A MINIMUM MOUNTING SURFACE FOR TERMINAL 4.
 5. DIMENSIONS A AND B DO NOT INCLUDE MOLD FLASH OR GATE PROTRUSIONS. MOLD FLASH AND GATE PROTRUSIONS NOT TO EXCEED 0.025 (0.635) MAXIMUM.

DIM	INCHES		MILLIMETERS	
	MIN	MAX	MIN	MAX
A	0.386	0.403	9.804	10.236
B	0.356	0.368	9.042	9.347
C	0.170	0.180	4.318	4.572
D	0.026	0.036	0.660	0.914
E	0.045	0.055	1.143	1.397
F	0.051 REF		1.295 REF	
G	0.100 BSC		2.540 BSC	
H	0.539	0.579	13.691	14.707
J	0.125 MAX		3.175 MAX	
K	0.050 REF		1.270 REF	
L	0.000	0.010	0.000	0.254
M	0.088	0.102	2.235	2.591
N	0.018	0.026	0.457	0.660
P	0.058	0.078	1.473	1.981
R	5° REF		5° REF	
S	0.116 REF		2.946 REF	
U	0.200 MIN		5.080 MIN	
V	0.250 MIN		6.350 MIN	

D2T SUFFIX
CASE 936A-02
 Plastic Package
 (D²PAK)
 ISSUE A

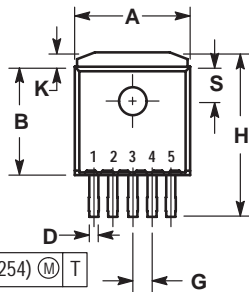
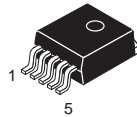

⊕ 0.010 (0.254) Ⓜ T

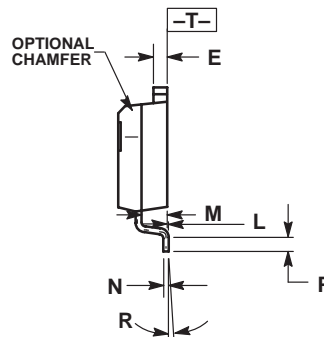
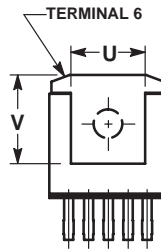
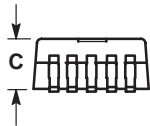

- NOTES:
1. DIMENSIONING AND TOLERANCING PER ANSI Y14.5M, 1982.
 2. CONTROLLING DIMENSION: INCH.
 3. TAB CONTOUR OPTIONAL WITHIN DIMENSIONS A AND K.
 4. DIMENSIONS U AND V ESTABLISH A MINIMUM MOUNTING SURFACE FOR TERMINAL 6.
 5. DIMENSIONS A AND B DO NOT INCLUDE MOLD FLASH OR GATE PROTRUSIONS. MOLD FLASH AND GATE PROTRUSIONS NOT TO EXCEED 0.025 (0.635) MAXIMUM.

DIM	INCHES		MILLIMETERS	
	MIN	MAX	MIN	MAX
A	0.386	0.403	9.804	10.236
B	0.356	0.368	9.042	9.347
C	0.170	0.180	4.318	4.572
D	0.026	0.036	0.660	0.914
E	0.045	0.055	1.143	1.397
G	0.067 BSC		1.702 BSC	
H	0.539	0.579	13.691	14.707
K	0.050 REF		1.270 REF	
L	0.000	0.010	0.000	0.254
M	0.088	0.102	2.235	2.591
N	0.018	0.026	0.457	0.660
P	0.058	0.078	1.473	1.981
R	5° REF		5° REF	
S	0.116 REF		2.946 REF	
U	0.200 MIN		5.080 MIN	
V	0.250 MIN		6.350 MIN	

DT, DTB SUFFIX
CASE 948E-02
 Plastic Package
 (TSSOP-20)
 ISSUE A

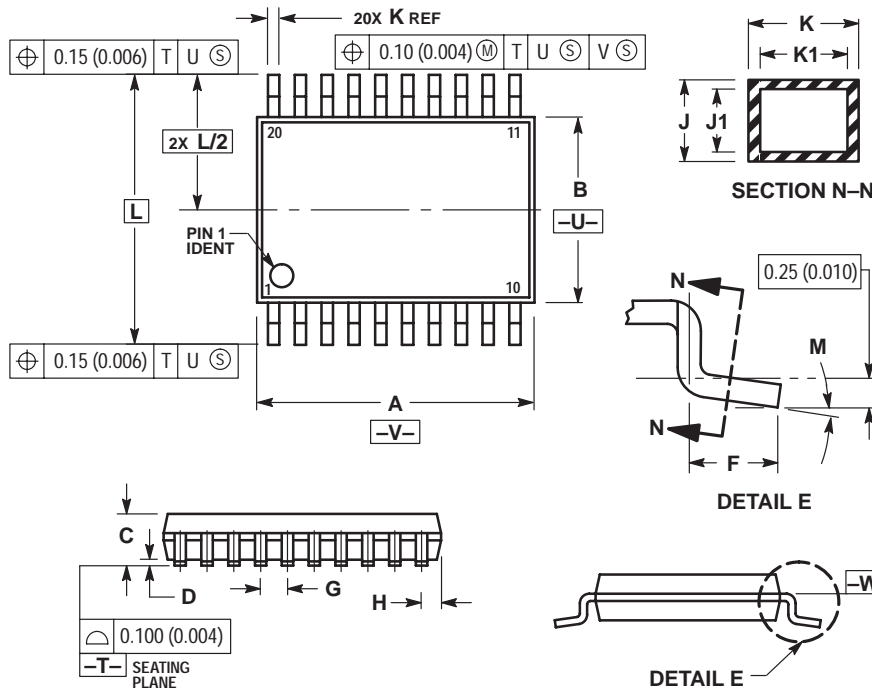
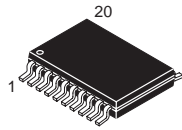

- NOTES:
1. DIMENSIONING AND TOLERANCING PER ANSI Y14.5M, 1982.
 2. CONTROLLING DIMENSION: MILLIMETER.
 3. DIMENSION A DOES NOT INCLUDE MOLD FLASH, PROTRUSIONS OR GATE BURRS. MOLD FLASH OR GATE BURRS SHALL NOT EXCEED 0.15 (0.006) PER SIDE.
 4. DIMENSION B DOES NOT INCLUDE INTERLEAD FLASH OR PROTRUSION. INTERLEAD FLASH OR PROTRUSION SHALL NOT EXCEED 0.25 (0.010) PER SIDE.
 5. DIMENSION K DOES NOT INCLUDE DAMBAR PROTRUSION. ALLOWABLE DAMBAR PROTRUSION SHALL BE 0.08 (0.003) TOTAL IN EXCESS OF THE K DIMENSION AT MAXIMUM MATERIAL CONDITION.
 6. TERMINAL NUMBERS ARE SHOWN FOR REFERENCE ONLY.
 7. DIMENSION A AND B ARE TO BE DETERMINED AT DATUM PLANE -W-.

DIM	MILLIMETERS		INCHES	
	MIN	MAX	MIN	MAX
A	6.40	6.60	0.252	0.260
B	4.30	4.50	0.169	0.177
C	---	1.20	---	0.047
D	0.05	0.15	0.002	0.006
F	0.50	0.75	0.020	0.030
G	0.65 BSC		0.026 BSC	
H	0.27	0.37	0.011	0.015
J	0.09	0.20	0.004	0.008
J1	0.09	0.16	0.004	0.006
K	0.19	0.30	0.007	0.012
K1	0.19	0.25	0.007	0.010
L	6.40 BSC		0.252 BSC	
M	0°	8°	0°	8°

DTB SUFFIX
CASE 948F-01
 Plastic Package
 (TSSOP-16, TSSOP-16L)
 ISSUE O

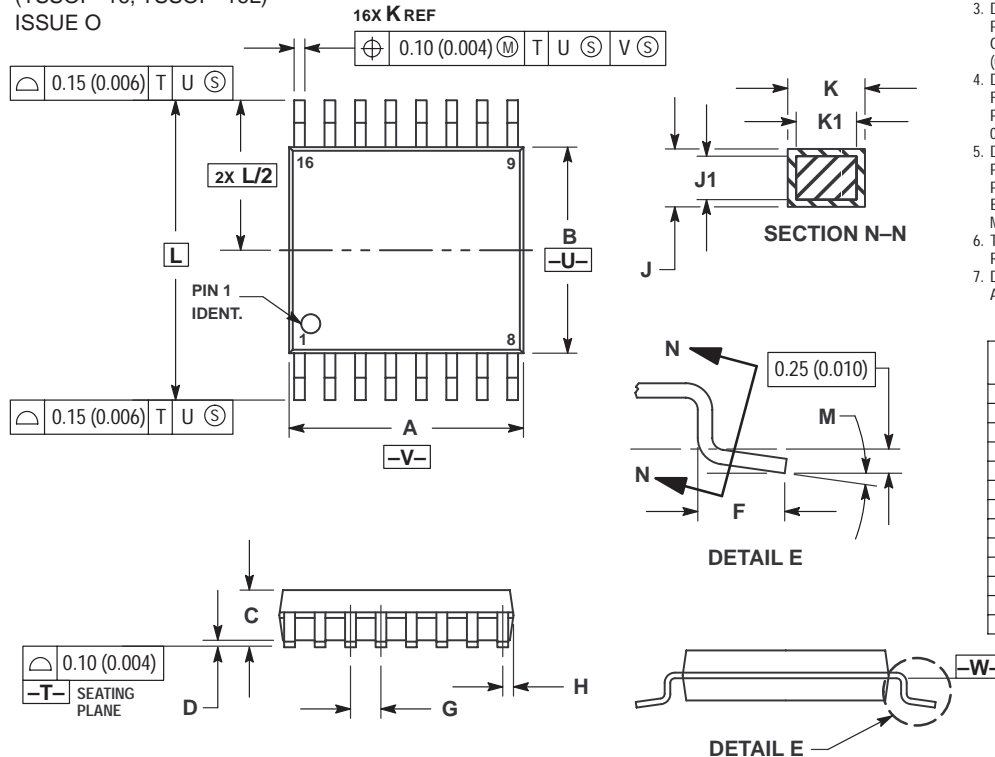
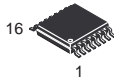

- NOTES:
1. DIMENSIONING AND TOLERANCING PER ANSI Y14.5M, 1982.
 2. CONTROLLING DIMENSION: MILLIMETER.
 3. DIMENSION A DOES NOT INCLUDE MOLD FLASH, PROTRUSIONS OR GATE BURRS. MOLD FLASH OR GATE BURRS SHALL NOT EXCEED 0.15 (0.006) PER SIDE.
 4. DIMENSION B DOES NOT INCLUDE INTERLEAD FLASH OR PROTRUSION. INTERLEAD FLASH OR PROTRUSION SHALL NOT EXCEED 0.25 (0.010) PER SIDE.
 5. DIMENSION K DOES NOT INCLUDE DAMBAR PROTRUSION. ALLOWABLE DAMBAR PROTRUSION SHALL BE 0.08 (0.003) TOTAL IN EXCESS OF THE K DIMENSION AT MAXIMUM MATERIAL CONDITION.
 6. TERMINAL NUMBERS ARE SHOWN FOR REFERENCE ONLY.
 7. DIMENSION A AND B ARE TO BE DETERMINED AT DATUM PLANE -W-.

DIM	MILLIMETERS		INCHES	
	MIN	MAX	MIN	MAX
A	4.90	5.10	0.193	0.200
B	4.30	4.50	0.169	0.177
C	---	1.20	---	0.047
D	0.05	0.15	0.002	0.006
F	0.50	0.75	0.020	0.030
G	0.65 BSC		0.026 BSC	
H	0.18	0.28	0.007	0.011
J	0.09	0.20	0.004	0.008
J1	0.09	0.16	0.004	0.006
K	0.19	0.30	0.007	0.012
K1	0.19	0.25	0.007	0.010
L	6.40 BSC		0.252 BSC	
M	0°	8°	0°	8°

DTB SUFFIX
CASE 948G-01
 Plastic Package
 (TSSOP-14)
 ISSUE O

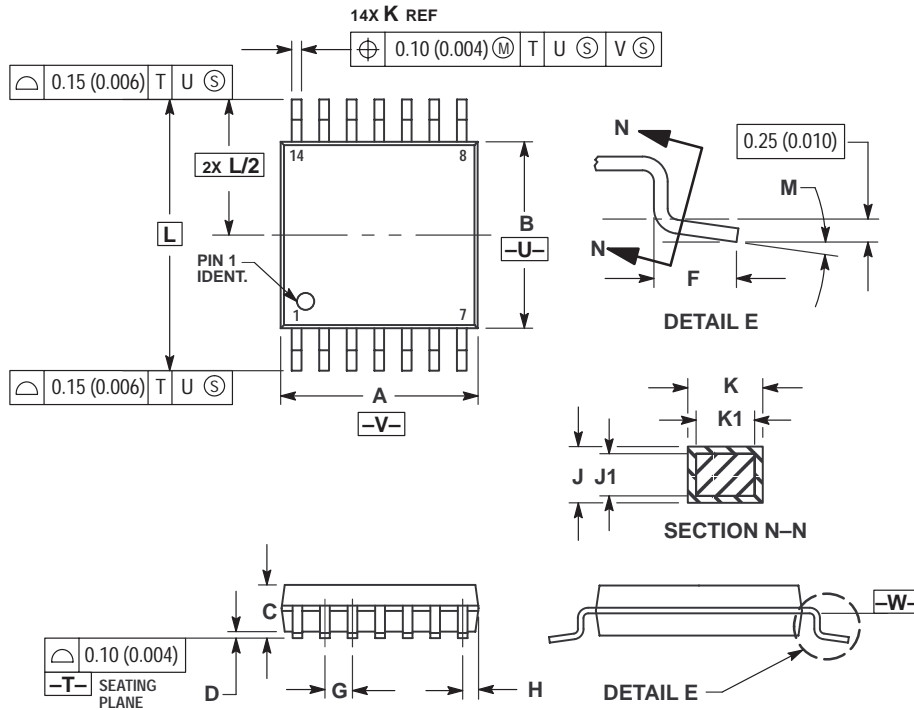

NOTES:

- 1 DIMENSIONING AND TOLERANCING PER ANSI Y14.5M, 1982.
- 2 CONTROLLING DIMENSION: MILLIMETER.
- 3 DIMENSION A DOES NOT INCLUDE MOLD FLASH, PROTRUSIONS OR GATE BURRS. MOLD FLASH OR GATE BURRS SHALL NOT EXCEED 0.15 (0.006) PER SIDE.
- 4 DIMENSION B DOES NOT INCLUDE INTERLEAD FLASH OR PROTRUSION. INTERLEAD FLASH OR PROTRUSION SHALL NOT EXCEED 0.25 (0.010) PER SIDE.
- 5 DIMENSION K DOES NOT INCLUDE DAMBAR PROTRUSION. ALLOWABLE DAMBAR PROTRUSION SHALL BE 0.08 (0.003) TOTAL IN EXCESS OF THE K DIMENSION AT MAXIMUM MATERIAL CONDITION.
- 6 TERMINAL NUMBERS ARE SHOWN FOR REFERENCE ONLY.
- 7 DIMENSION A AND B ARE TO BE DETERMINED AT DATUM PLANE -W-.

DIM	MILLIMETERS		INCHES	
	MIN	MAX	MIN	MAX
A	4.90	5.10	0.193	0.200
B	4.30	4.50	0.169	0.177
C	---	1.20	---	0.047
D	0.05	0.15	0.002	0.006
F	0.50	0.75	0.020	0.030
G	0.65 BSC		0.026 BSC	
H	0.50	0.60	0.020	0.024
J	0.09	0.20	0.004	0.008
J1	0.09	0.16	0.004	0.006
K	0.19	0.30	0.007	0.012
K1	0.19	0.25	0.007	0.010
L	6.40 BSC		0.252 BSC	
M	0°	8°	0°	8°

DTB SUFFIX
CASE 948H-01
 Plastic Package
 ISSUE O

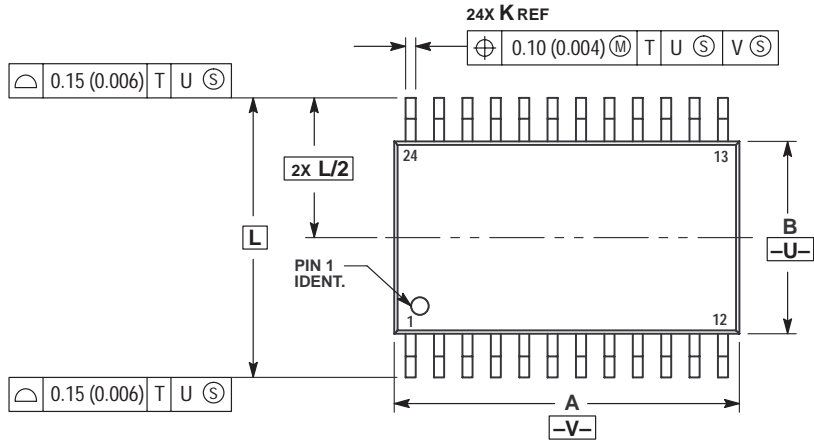
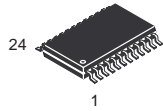

- NOTES:
1. DIMENSIONING AND TOLERANCING PER ANSI Y14.5M, 1982.
 2. CONTROLLING DIMENSION: MILLIMETER.
 3. DIMENSION A DOES NOT INCLUDE MOLD FLASH, PROTRUSIONS OR GATE BURRS. MOLD FLASH OR GATE BURRS SHALL NOT EXCEED 0.15 (0.006) PER SIDE.
 4. DIMENSION B DOES NOT INCLUDE INTERLEAD FLASH OR PROTRUSION. INTERLEAD FLASH OR PROTRUSION SHALL NOT EXCEED 0.25 (0.010) PER SIDE.
 5. DIMENSION K DOES NOT INCLUDE DAMBAR PROTRUSION. ALLOWABLE DAMBAR PROTRUSION SHALL BE 0.08 (0.003) TOTAL IN EXCESS OF THE K DIMENSION AT MAXIMUM MATERIAL CONDITION.
 6. TERMINAL NUMBERS ARE SHOWN FOR REFERENCE ONLY.
 7. DIMENSION A AND B ARE TO BE DETERMINED AT DATUM PLANE -W-.

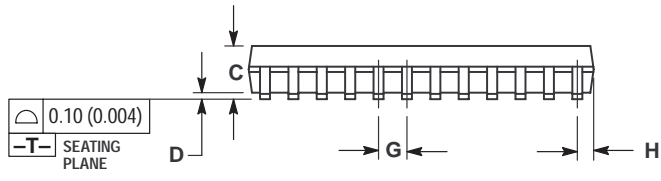

DIM	MILLIMETERS		INCHES	
	MIN	MAX	MIN	MAX
A	7.70	7.90	0.303	0.311
B	4.30	4.50	0.169	0.177
C	---	1.20	---	0.047
D	0.05	0.15	0.002	0.006
F	0.50	0.75	0.020	0.030
G	0.65 BSC		0.026 BSC	
H	0.27	0.37	0.011	0.015
J	0.09	0.20	0.004	0.008
J1	0.09	0.16	0.004	0.006
K	0.19	0.30	0.007	0.012
K1	0.19	0.25	0.007	0.010
L	6.40 BSC		0.252 BSC	
M	0°	8°	0°	8°

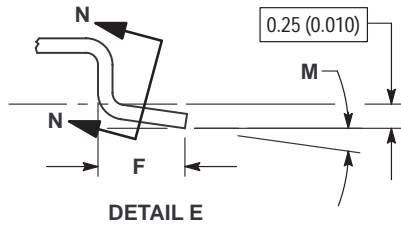
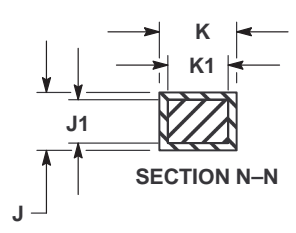
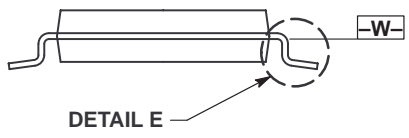

DTB SUFFIX
CASE 948J-01
 Plastic Package
 (TSSOP-8)
 ISSUE O

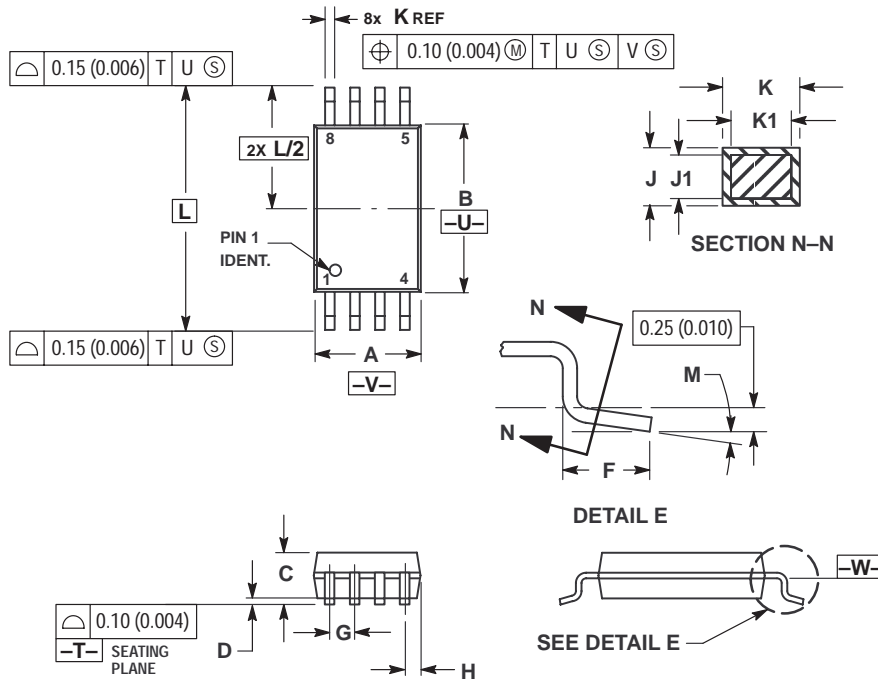

- NOTES:
- 1 DIMENSIONING AND TOLERANCING PER ANSI Y14.5M, 1982.
 - 2 CONTROLLING DIMENSION: MILLIMETER.
 - 3 DIMENSION A DOES NOT INCLUDE MOLD FLASH, PROTRUSIONS OR GATE BURRS. MOLD FLASH OR GATE BURRS SHALL NOT EXCEED 0.15 (0.006) PER SIDE.
 - 4 DIMENSION B DOES NOT INCLUDE INTERLEAD FLASH OR PROTRUSION. INTERLEAD FLASH OR PROTRUSION SHALL NOT EXCEED 0.25 (0.010) PER SIDE.
 - 5 DIMENSION K DOES NOT INCLUDE DAMBAR PROTRUSION. ALLOWABLE DAMBAR PROTRUSION SHALL BE 0.08 (0.003) TOTAL IN EXCESS OF THE K DIMENSION AT MAXIMUM MATERIAL CONDITION.
 - 6 TERMINAL NUMBERS ARE SHOWN FOR REFERENCE ONLY.
 - 7 DIMENSION A AND B ARE TO BE DETERMINED AT DATUM PLANE -W-.

DIM	MILLIMETERS		INCHES	
	MIN	MAX	MIN	MAX
A	2.90	3.10	0.114	0.122
B	4.30	4.50	0.169	0.177
C	---	1.20	---	0.047
D	0.05	0.15	0.002	0.006
F	0.50	0.75	0.020	0.030
G	0.65 BSC		0.026 BSC	
H	0.50	0.60	0.020	0.024
J	0.09	0.20	0.004	0.008
J1	0.09	0.16	0.004	0.006
K	0.19	0.30	0.007	0.012
K1	0.19	0.25	0.007	0.010
L	6.40 BSC		0.252 BSC	
M	0°	8°	0°	8°

M SUFFIX
CASE 967-01
 Plastic Package
 (EIAJ-20)
 ISSUE O

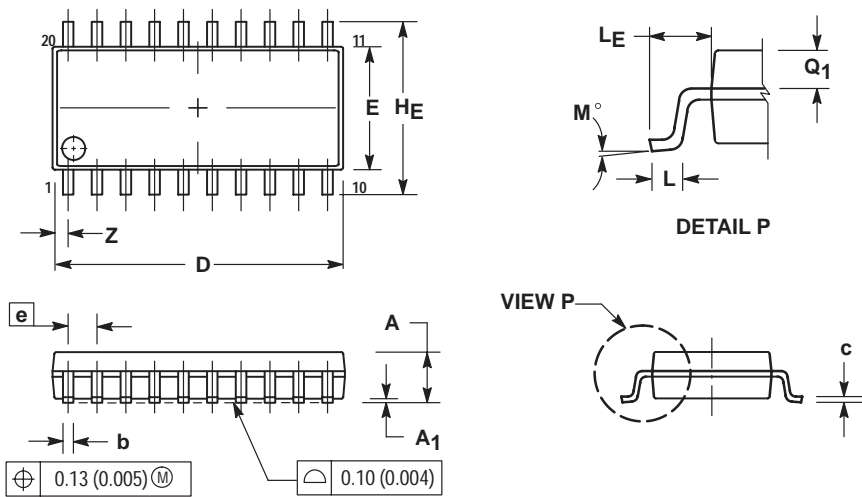
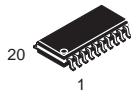

- NOTES:
- 1 DIMENSIONING AND TOLERANCING PER ANSI Y14.5M, 1982.
 - 2 CONTROLLING DIMENSION: MILLIMETER.
 - 3 DIMENSIONS D AND E DO NOT INCLUDE MOLD FLASH OR PROTRUSIONS AND ARE MEASURED AT THE PARTING LINE. MOLD FLASH OR PROTRUSIONS SHALL NOT EXCEED 0.15 (0.006) PER SIDE.
 - 4 TERMINAL NUMBERS ARE SHOWN FOR REFERENCE ONLY.
 - 5 THE LEAD WIDTH DIMENSION (b) DOES NOT INCLUDE DAMBAR PROTRUSION. ALLOWABLE DAMBAR PROTRUSION SHALL BE 0.08 (0.003) TOTAL IN EXCESS OF THE LEAD WIDTH DIMENSION AT MAXIMUM MATERIAL CONDITION. DAMBAR CANNOT BE LOCATED ON THE LOWER RADIUS OR THE FOOT. MINIMUM SPACE BETWEEN PROTRUSIONS AND ADJACENT LEAD TO BE 0.46 (0.018).

DIM	MILLIMETERS		INCHES	
	MIN	MAX	MIN	MAX
A	---	2.05	---	0.081
A1	0.05	0.20	0.002	0.008
b	0.35	0.50	0.014	0.020
c	0.18	0.27	0.007	0.011
D	12.35	12.80	0.486	0.504
E	5.10	5.45	0.201	0.215
e	1.27 BSC		0.050 BSC	
H _F	7.40	8.20	0.291	0.323
L	0.50	0.85	0.020	0.033
L _F	1.10	1.50	0.043	0.059
M	0°	10°	0°	10°
Q ₁	0.70	0.90	0.028	0.035
Z	---	0.81	---	0.032

FTB SUFFIX
CASE 976-01
Plastic Package
(TQFP-20)
ISSUE O

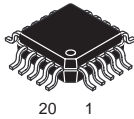

20 1

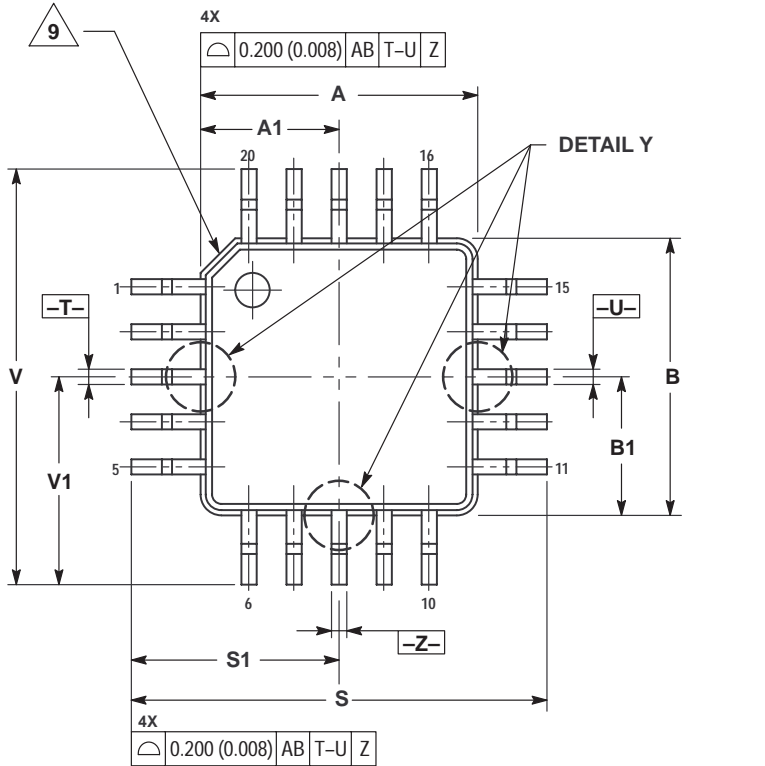

- NOTES:
1. DIMENSIONING AND TOLERANCING PER ANSI Y14.5M, 1982.
 2. CONTROLLING DIMENSION: MILLIMETER.
 3. DATUM PLANE -AB- IS LOCATED AT BOTTOM OF LEAD AND IS COINCIDENT WITH THE LEAD WHERE THE LEAD EXITS THE PLASTIC BODY AT THE BOTTOM OF THE PARTING LINE.
 4. DATUMS -T-, -U-, AND -Z- TO BE DETERMINED AT DATUM PLANE -AB-.
 5. DIMENSIONS S AND V TO BE DETERMINED AT DATUM PLANE -AC-.
 6. DIMENSIONS A AND B DO NOT INCLUDE MOLD PROTRUSION. ALLOWABLE PROTRUSION IS 0.250 (0.010) PER SIDE. DIMENSIONS A AND B DO INCLUDE MOLD MISMATCH AND ARE DETERMINED AT DATUM PLANE -AB-.
 7. DIMENSION D DOES NOT INCLUDE DAMBAR PROTRUSION. DAMBAR PROTRUSION SHALL NOT CAUSE THE D DIMENSION TO EXCEED 0.350 (0.014).
 8. MINIMUM SOLDER PLATE THICKNESS SHALL BE 0.0076 (0.0003).
 9. EXACT SHAPE OF EACH CORNER IS OPTIONAL.

DIM	MILLIMETERS		INCHES	
	MIN	MAX	MIN	MAX
A	4.000 BSC		0.157 BSC	
A1	2.000 BSC		0.079 BSC	
B	4.000 BSC		0.157 BSC	
B1	2.000 BSC		0.079 BSC	
C	1.400	1.600	0.055	0.063
D	0.170	0.270	0.007	0.011
E	1.350	1.450	0.053	0.057
F	0.170	0.230	0.007	0.009
G	0.650 BSC		0.026 BSC	
H	0.050	0.150	0.002	0.006
J	0.090	0.200	0.004	0.008
K	0.500	0.700	0.020	0.028
M	12° REF		12° REF	
N	0.090	0.160	0.004	0.006
P	0.250 BSC		0.010 BSC	
Q	1°	5°	1°	5°
R	0.150	0.250	0.006	0.010
S	6.000 BSC		0.236 BSC	
S1	3.000 BSC		0.118 BSC	
V	6.000 BSC		0.236 BSC	
V1	3.000 BSC		0.118 BSC	
W	0.200 REF		0.008 REF	
X	1.000 REF		0.039 REF	

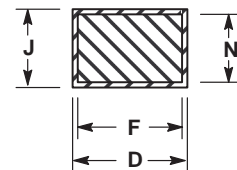
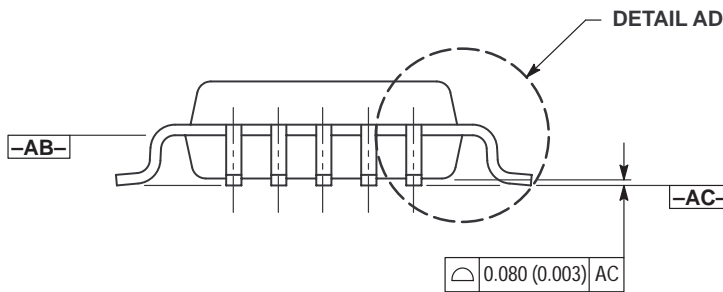

$\oplus 0.080 (0.003) \text{ } \textcircled{S} \text{ } AC \text{ } T-U \text{ } \textcircled{S} \text{ } Z \text{ } \textcircled{S}$

SECTION AE-AE

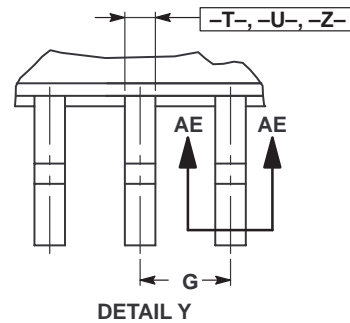
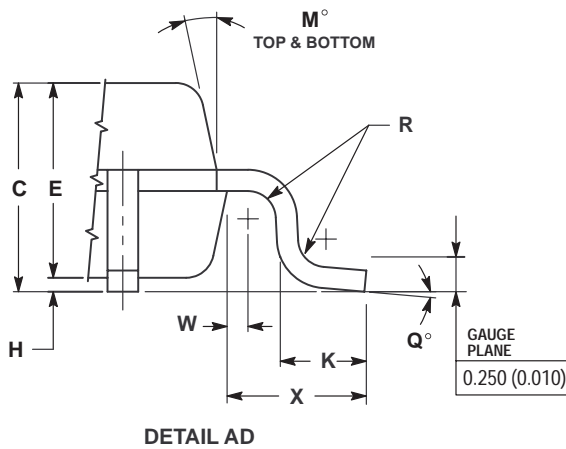

FTA SUFFIX
CASE 977-01
Plastic Package
ISSUE O

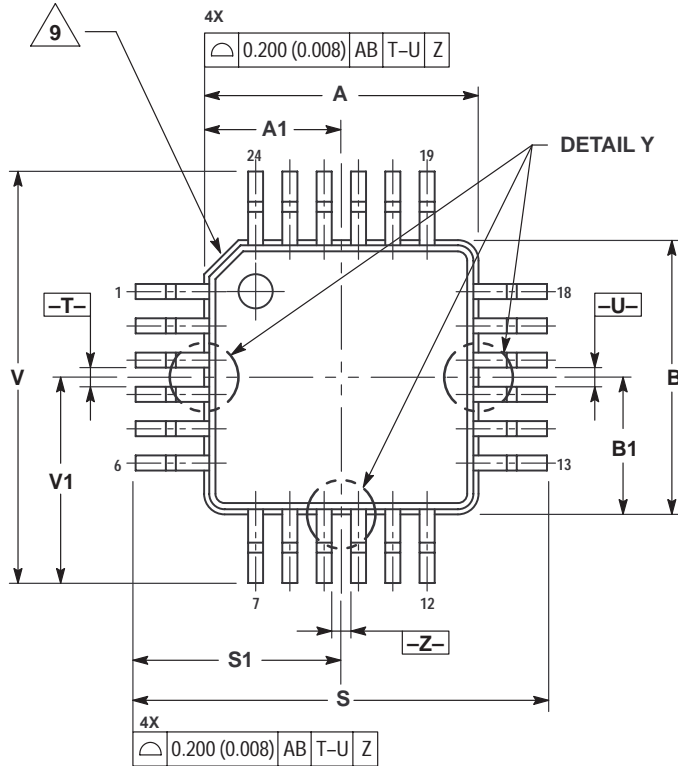
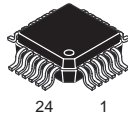

- NOTES:
1. DIMENSIONING AND TOLERANCING PER ANSI Y14.5M, 1982.
 2. CONTROLLING DIMENSION: MILLIMETER.
 3. DATUM PLANE -AB- IS LOCATED AT BOTTOM OF LEAD AND IS COINCIDENT WITH THE LEAD WHERE THE LEAD EXITS THE PLASTIC BODY AT THE BOTTOM OF THE PARTING LINE.
 4. DATUMS -T-, -U-, AND -Z- TO BE DETERMINED AT DATUM PLANE -AB-.
 5. DIMENSIONS S AND V TO BE DETERMINED AT DATUM PLANE -AC-.
 6. DIMENSIONS A AND B DO NOT INCLUDE MOLD PROTRUSION. ALLOWABLE PROTRUSION IS 0.250 (0.010) PER SIDE. DIMENSIONS A AND B DO INCLUDE MOLD MISMATCH AND ARE DETERMINED AT DATUM PLANE -AB-.
 7. DIMENSION D DOES NOT INCLUDE DAMBAR PROTRUSION. DAMBAR PROTRUSION SHALL NOT CAUSE THE D DIMENSION TO EXCEED 0.350 (0.014).
 8. MINIMUM SOLDER PLATE THICKNESS SHALL BE 0.0076 (0.0003).
 9. EXACT SHAPE OF EACH CORNER IS OPTIONAL.

DIM	MILLIMETERS		INCHES	
	MIN	MAX	MIN	MAX
A	4.000 BSC		0.157 BSC	
A1	2.000 BSC		0.079 BSC	
B	4.000 BSC		0.157 BSC	
B1	2.000 BSC		0.079 BSC	
C	1.400	1.600	0.055	0.063
D	0.170	0.270	0.007	0.011
E	1.350	1.450	0.053	0.057
F	0.170	0.230	0.007	0.009
G	0.500 BSC		0.020 BSC	
H	0.050	0.150	0.002	0.006
J	0.090	0.200	0.004	0.008
K	0.500	0.700	0.020	0.028
M	12° REF		12° REF	
N	0.090	0.160	0.004	0.006
P	0.250 BSC		0.010 BSC	
Q	1°	5°	1°	5°
R	0.150	0.250	0.006	0.010
S	6.000 BSC		0.236 BSC	
S1	3.000 BSC		0.118 BSC	
V	6.000 BSC		0.236 BSC	
V1	3.000 BSC		0.118 BSC	
W	0.200 REF		0.008 REF	
X	1.000 REF		0.039 REF	

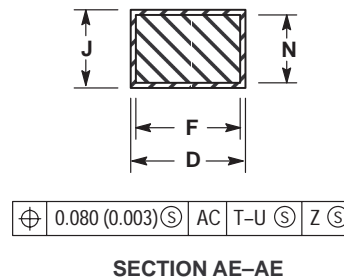
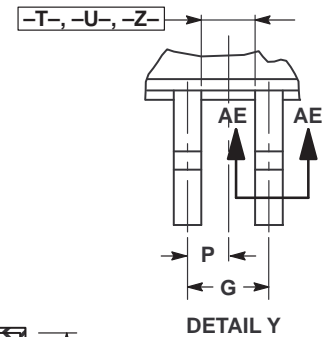
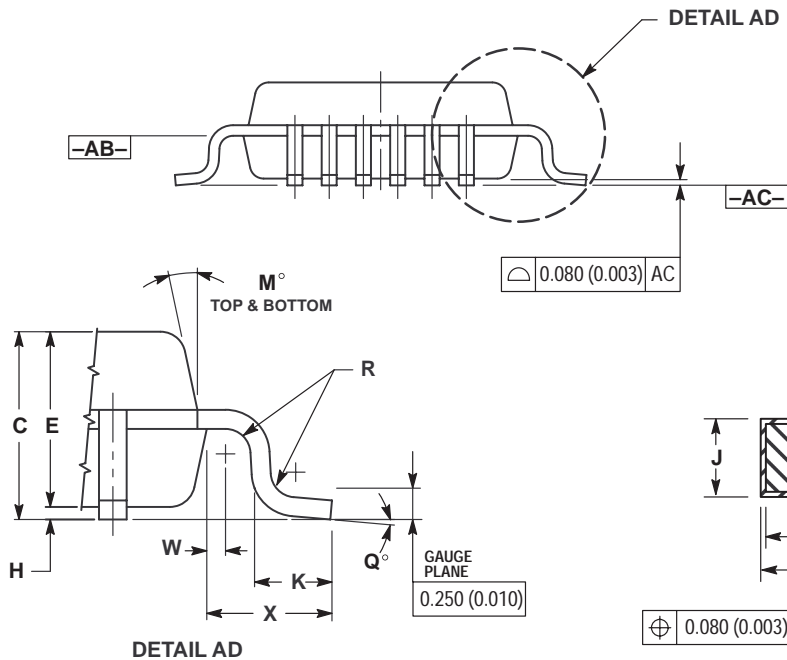

N SUFFIX
CASE 1212-01
 Plastic Package
 (SOT-23)
 ISSUE O

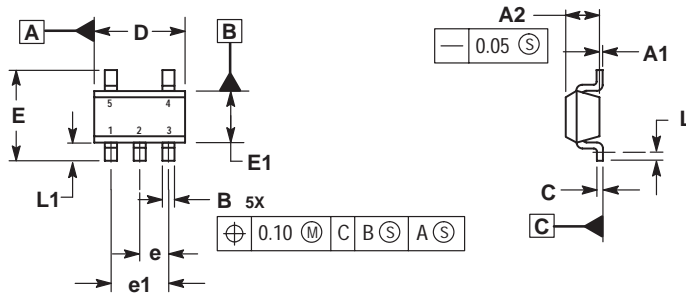

- NOTES:
 1. DIMENSIONS ARE IN MILLIMETERS.
 2. INTERPRET DIMENSIONS AND TOLERANCES PER ASME Y14.5M, 1994.
 3. DATUM C IS A SEATING PLANE.

MILLIMETERS		
DIM	MIN	MAX
A1	0.00	0.10
A2	1.00	1.30
B	0.30	0.50
C	0.10	0.25
D	2.80	3.00
E	2.50	3.10
E1	1.50	1.80
e	0.95 BSC	
e1	1.90 BSC	
L	0.20	----
L1	0.45	0.75

H SUFFIX
CASE 1213-01
 Plastic Package
 (SOT-89)
 ISSUE O

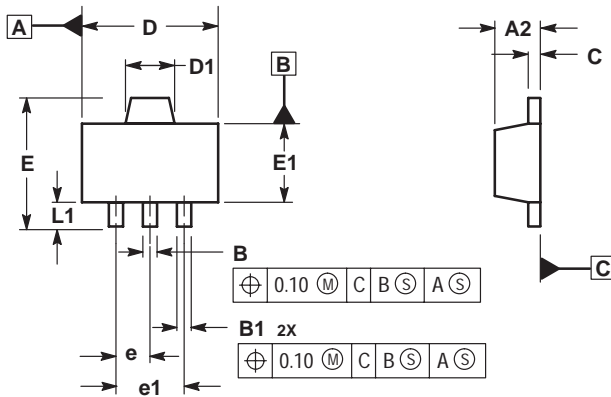

- NOTES:
 1. DIMENSIONS ARE IN MILLIMETERS.
 2. INTERPRET DIMENSIONS AND TOLERANCING PER ASME Y14.5M, 1994.
 3. DATUM C IS A SEATING PLANE.

MILLIMETERS		
DIM	MIN	MAX
A2	1.40	1.60
B	0.37	0.57
B1	0.32	0.52
C	0.30	0.50
D	4.40	4.60
D1	1.50	1.70
E	----	4.25
E1	2.40	2.60
e	1.50 BSC	
e1	3.00 BSC	
L1	0.80	----