

# HYBRID VOLTAGE REGULATORS

CJSE001 CJSE002 CJSE003 CJSE004 CJSE005 CJSE006

## FIXED OUTPUT HYBRID VOLTAGE REGULATORS

± 15V

3 AMPERES

### FEATURES

POSITIVE, NEGATIVE SUPPLY OPERATION  
 3A CURRENT RATING  
 50V LINE VOLTAGE CAPABILITY  
 LINE AND LOAD REGULATION  $\leq \pm 0.5\%$   
 THREE-TERMINAL SIMPLICITY

### APPLICATIONS

- DC MOTOR SUPPLIES
- MEDICAL ELECTRONICS
- INDUSTRIAL CONTROLS
- DISTRIBUTED POWER SYSTEMS
- MILITARY EQUIPMENT, SPACE AND TELECOMMUNICATIONS
- COMPUTERS
- INSTRUMENTATION
- DATA TERMINALS

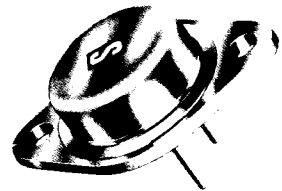

TO-3 (2 PINS)

### MAXIMUM RATINGS

		CJSE001 CJSE004	CJSE002 CJSE005	CJSE003 CJSE006
$ \pm V_{in} $	INPUT VOLTAGE	50 V		
$I_{opk}$	PEAK LOAD CURRENT	3 A		
$T_A$	OPERATING TEMPERATURE	-55°C to +150°C		
$T_{stg}$	STORAGE TEMPERATURE	-55°C to +150°C		
$R_{\theta JC}$	THERMAL RESISTANCE, JUNCTION TO CASE	1.67°C/W		
$P_D$	POWER DISSIPATION (25°C)	90 W		

15 V REGULATORS	CJSE	001	002	003	004	005	006
Regulation, Line and Load	$T_C = 25^\circ\text{C}$	+15 ± .5%	-15 ± .5%	+15 ± .5%	-15 ± .5%	+15 ± .5%	-15 ± .5%
	$-55^\circ\text{C} \leq T_A \leq +125^\circ\text{C}$	± 3%	± 3%	± 2%	± 2%	± 1%	± 1%

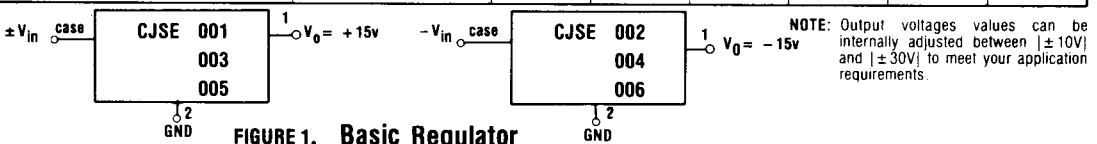

FIGURE 1. Basic Regulator

**HYBRID VOLTAGE REGULATORS**  
**CJSE001 CJSE002 CJSE003 CJSE004 CJSE005 CJSE006**

**ELECTRICAL CHARACTERISTICS** ( $\pm V_{in} = 25$  Vdc,  $\pm I_o = 2$  A,  $R_{sc} = .4\Omega$ ,  $T_c = +25^\circ\text{C}$  unless otherwise noted)

CHARACTERISTICS	SYMBOL	MIN.	MAX.	UNITS
INPUT VOLTAGE	$  \pm V_{in}  $	20	50	V
OUTPUT VOLTAGE RANGE	$\pm V_o^1$	14.85	15.15	V
OUTPUT VOLTAGE RANGE ( $-55^\circ\text{C} \leq T_A \leq +125^\circ\text{C}$ )	$\pm V_o^1$			
CJSE001 CJSE002		14.55	15.45	V
CJSE003 CJSE004		14.70	15.30	V
CJSE005 CJSE006		14.85	15.15	V
INPUT-OUTPUT VOLTAGE DIFF	$\pm \Delta V_i$	5.0		V
STANDBY CURRENT	$I_{in}^{1c}$		50	mA
SHORT CIRCUIT CURRENT ( $V_o = 0$ V)	$I_{sc}$		500	mA
RIPPLE ATTENUATION ( $  \pm V_{in}   = 25$ V, $I_o = 1.0$ A, $f = 120$ Hz)		60		dB
TEMPERATURE COEFFICIENT ( $-55^\circ\text{C} \leq T_A \leq +125^\circ\text{C}$ )	$\frac{\Delta V_o}{V_o \Delta T}$			
CJSE001 CJSE002			$\pm 0.020$	%/ $^\circ\text{C}$
CJSE003 CJSE004			$\pm 0.010$	%/ $^\circ\text{C}$
CJSE005 CJSE006			$\pm 0.005$	%/ $^\circ\text{C}$

# HYBRID VOLTAGE REGULATORS

CJSE001 CJSE002 CJSE003 CJSE004 CJSE005 CJSE006

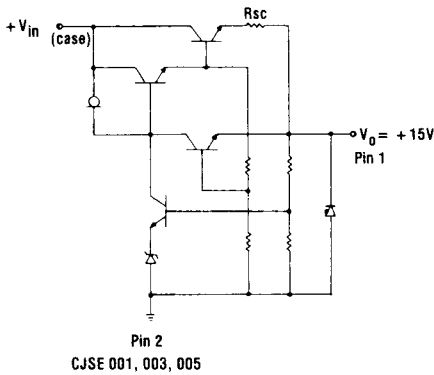

FIGURE 2

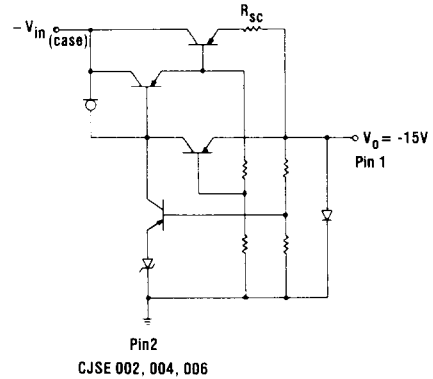

FIGURE 3

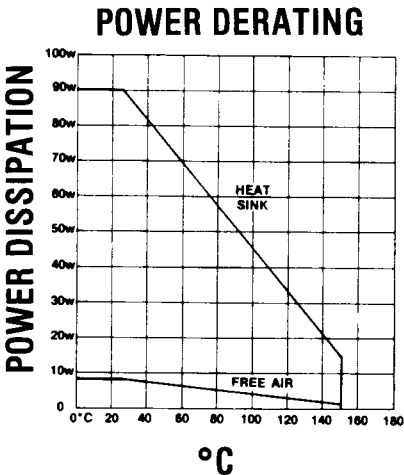

FIGURE 4

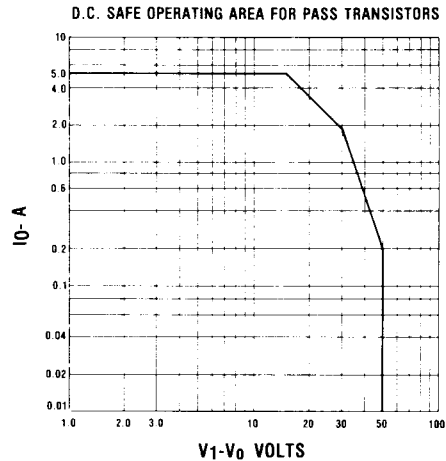

FIGURE 5

## NOTES:

1. Regulators incorporate a FET constant current source, which provides current mode regulation. A minimum input-output voltage differential of 5 volts is recommended to bias the FET into its constant current region. At lower voltages the FET becomes resistive, and regulation reverts to the basic mode.
2. Foldback current limiting is accomplished in the regulators as shown in Fig. 6.
3. Output current and power capability may be increased by driving one or more external power transistors. Maintain safe operating conditions for both regulator and the external transistor.

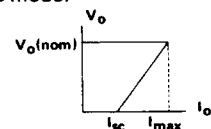

FIGURE 6