

# SF1005FCT THRU SF1060FCT

## List

List..... 1

Package outline..... 2

Features..... 2

Mechanical data..... 2

Maximum ratings .....2

Rating and characteristic curves..... 3

Pinning information.....4

Marking..... 4

Tube packing.....4

Suggested thermal profiles for soldering processes..... 5

High reliability test capabilities.....6

# SF1005FCT THRU SF1060FCT

## 10A Super Fast Recovery Rectifiers - 50V-600V

### Package outline

### Features

- Dual rectifier construction, positive centetap, offer 5.0A half wave and 10.0A full wave rectification
- High surge current capability.
- Super fast recovery time for switching mode application.
- Low power loss.
- Glass passivated chip junctions.
- Lead-free parts meet environmental standards of MIL-STD-19500/228
- Suffix "-H" indicates Halogen-free parts, ex. SF1005FCT-H.

### Mechanical data

- Epoxy : UL94-V0 rated flame retardant
- Case : JEDEC ITO-220AB molded plastic body over passivated chip
- Lead : Axial leads, solderable per MIL-STD-202, Method 208 guaranteed
- Polarity: As marked
- Mounting Position : Any
- Weight : Approximated 1.70 gram

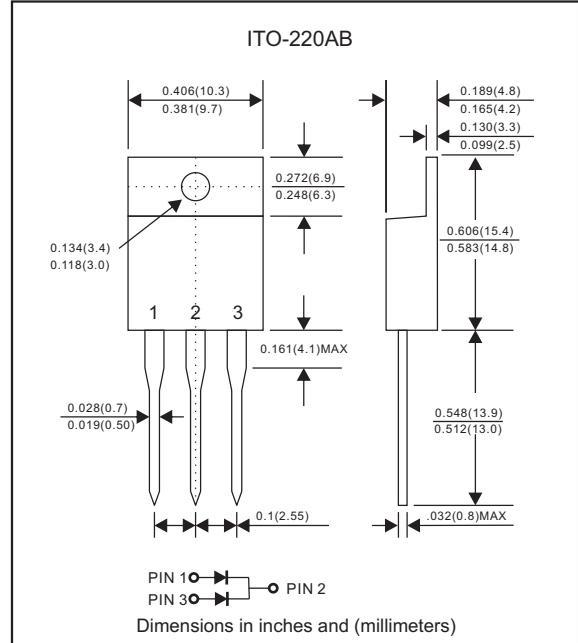

### Maximum ratings (AT $T_A=25^{\circ}\text{C}$ unless otherwise noted)

PARAMETER	SYMBOLS	SF1005FCT	SF1010FCT	SF1020FCT	SF1040FCT	SF1060FCT	UNIT
Maximum repetitive peak reverse voltage	$V_{RRM}$	50	100	200	400	600	V
Maximum RMS voltage	$V_{RMS}$	35	70	140	280	420	V
Maximum DC blocking voltage	$V_{DC}$	50	100	200	400	600	V
Maximum average forward rectified current	$I_o$	10					A
Peak forward surge current 8.3ms single half sine-wave(JEDEC method)	$I_{FSM}$	100					A
Operating junction temperature range	$T_J$	-55 to +150					$^{\circ}\text{C}$
Storage temperature range	$T_{STG}$	-65 to +175					$^{\circ}\text{C}$

### Electrical Characteristics (AT $T_A=25^{\circ}\text{C}$ unless otherwise noted)

PARAMETER	SYMBOLS	SF1005FCT	SF1010FCT	SF1020FCT	SF1040FCT	SF1060FCT	UNIT
Maximum forward voltage per leg at $I_F=5A$	$V_F$	0.98			1.30	1.70	V
Maximum DC reverse current at $T_J=25^{\circ}\text{C}$ at rated DC blocking voltage per leg at $T_J=125^{\circ}\text{C}$	$I_R$	5.0			250		$\mu\text{A}$ $\mu\text{A}$
Maximum reverse recovery time per leg (Note 1)	$t_{rr}$	35					ns

### Thermal Characteristics

PARAMETER	SYMBOLS	SF1005FCT	SF1010FCT	SF1020FCT	SF1040FCT	SF1060FCT	UNIT
Typical thermal resistance junction to case per leg	$R_{\theta JC}$	3.0					$^{\circ}\text{C}/\text{W}$

Note 1: Reverse recovery time test condition,  $I_F=0.5A$ ,  $I_R=1.0A$ ,  $I_{RR}=0.25A$

# Rating and characteristic curves (SF1005FCT THRU SF1060FCT)

FIG.1-TYPICAL FORWARD CURRENT DERATING CURVE

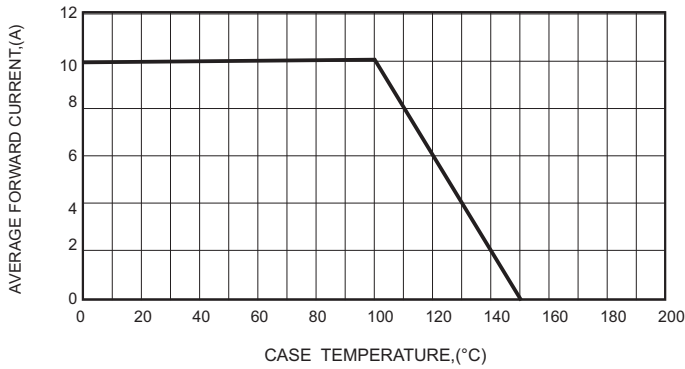

FIG.3-MAXIMUM NON-REPETITIVE FORWARD SURGE CURRENT

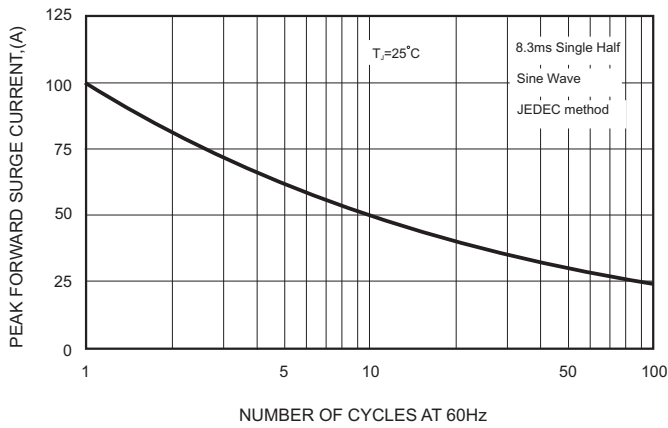

FIG.2-TYPICAL FORWARD CHARACTERISTICS

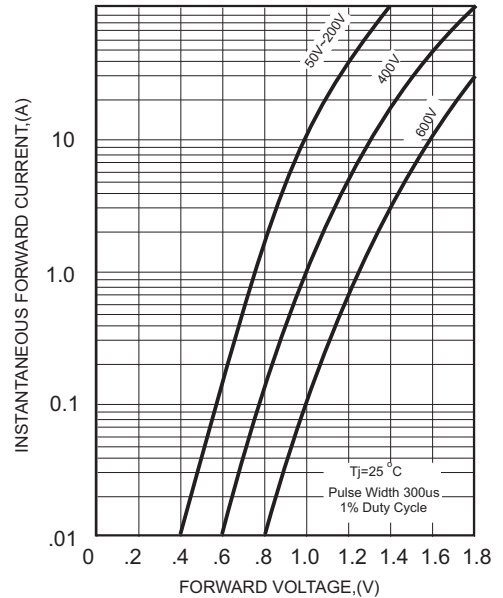

FIG.4 - TYPICAL REVERSE CHARACTERISTICS

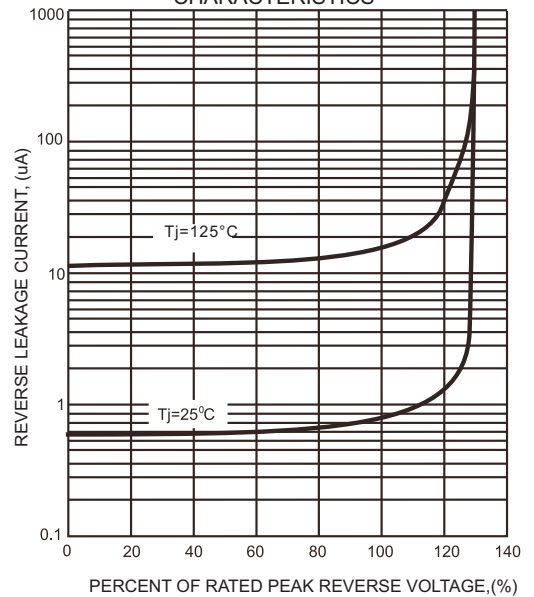
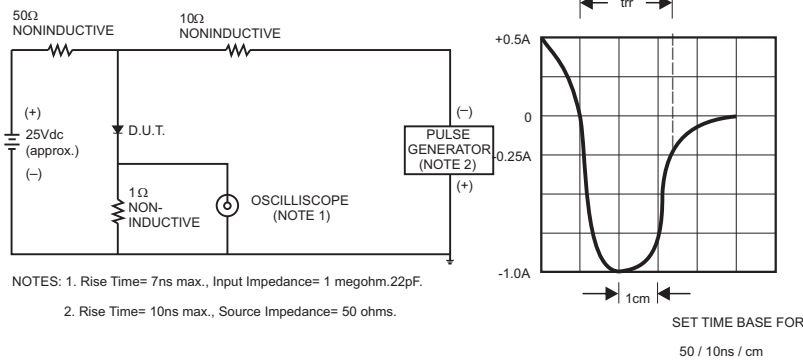
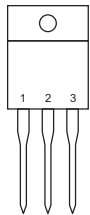
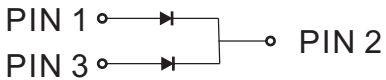

FIG.5- TEST CIRCUIT DIAGRAM AND REVERSE RECOVERY TIME CHARACTERISTICS



# SF1005FCT THRU SF1060FCT

## Pinning information

Pin	Simplified outline	Symbol
Pin1 anode Pin2 cathode Pin3 anode		

## Marking

Type number	Marking code
SF1005FCT	SF1005FCT
SF1010FCT	SF1010FCT
SF1020FCT	SF1020FCT
SF1040FCT	SF1040FCT
SF1060FCT	SF1060FCT

## Tube packing

PACKAGE	TUBE (pcs)	TUBE SIZE (m/m)	BOX (pcs)	INNER BOX (m/m)	CARTON SIZE (m/m)	CARTON (pcs)	APPROX. GROSS WEIGHT (kg)
ITO-220AB	50	525*32*7.0	1000	555*150*40	580*230*175	5,000	15.0

# SF1005FCT THRU SF1060FCT

## Suggested thermal profiles for soldering processes

### 1. Lead free temperature profile wave-soldering

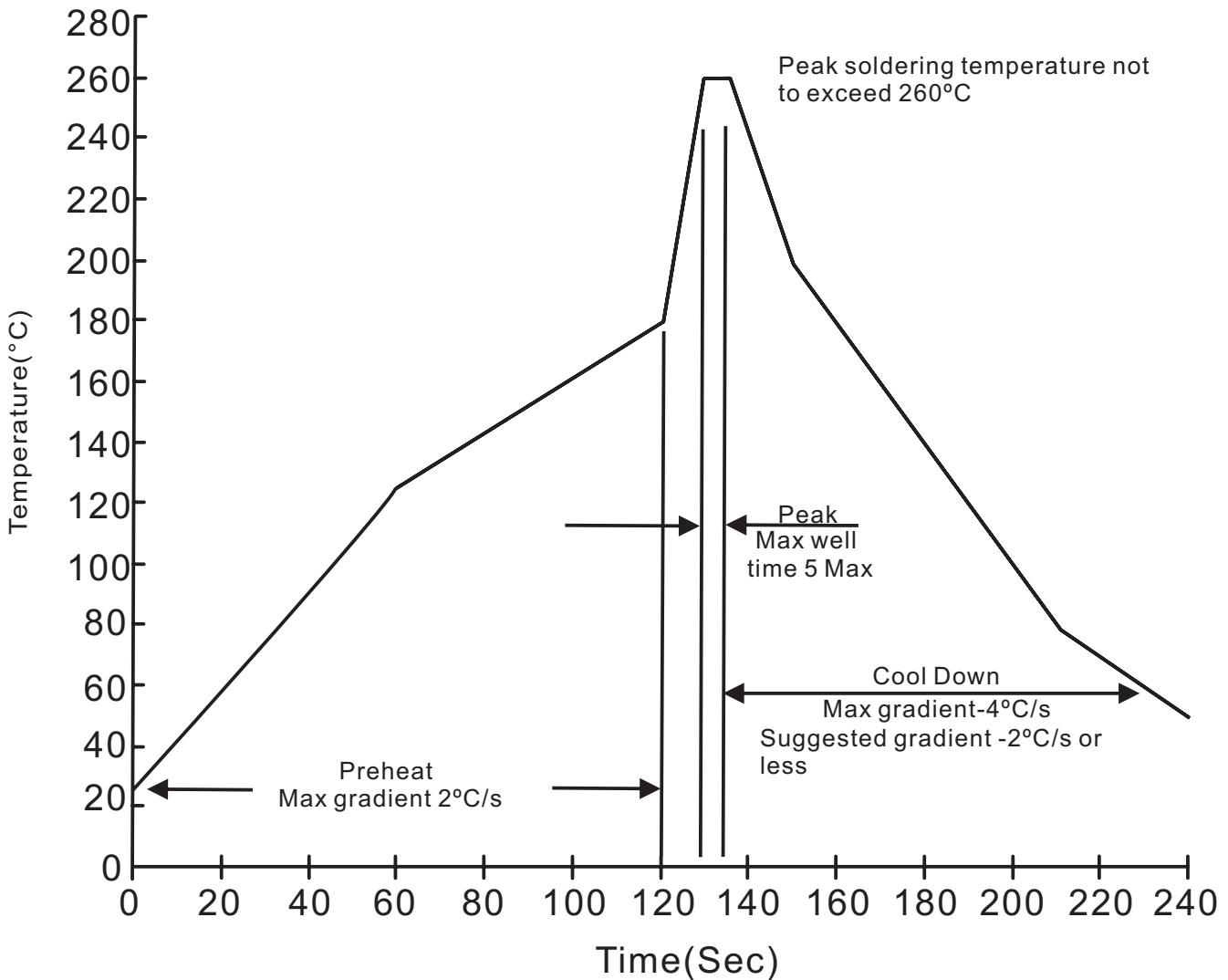

# SF1005FCT THRU SF1060FCT

## High reliability test capabilities

Item Test	Conditions	Reference
1. Solder Resistance	at $260\pm 5^{\circ}\text{C}$ for $10\pm 2\text{sec.}$ immerse body into solder $1/16''\pm 1/32''$	MIL-STD-750D METHOD-2031
2. Solderability	at $245\pm 5^{\circ}\text{C}$ for 5 sec.	MIL-STD-202F METHOD-208
3. High Temperature Reverse Bias	$V_R=80\%$ rate at $T_J=150^{\circ}\text{C}$ for 168 hrs.	MIL-STD-750D METHOD-1038
4. Forward Operation Life	Rated average rectifier current at $T_A=25^{\circ}\text{C}$ for 500hrs.	MIL-STD-750D METHOD-1027
5. Intermittent Operation Life	$T_A = 25^{\circ}\text{C}$ , $I_F = I_O$ On state: power on for 5 min. off state: power off for 5 min. on and off for 500 cycles.	MIL-STD-750D METHOD-1036
6. Pressure Cooker	$15P_{SIG}$ at $T_A=121^{\circ}\text{C}$ for 4 hrs.	JESD22-A102
7. Temperature Cycling	$-55^{\circ}\text{C}$ to $+125^{\circ}\text{C}$ dwelled for 30 min. and transferred for 5min. total 10 cycles.	MIL-STD-750D METHOD-1051
8. Forward Surge	8.3ms single half sine-wave , one surge.	MIL-STD-750D METHOD-4066-2
9. Humidity	at $T_A=85^{\circ}\text{C}$ , RH=85% for 1000hrs.	MIL-STD-750D METHOD-1021
10. High Temperature Storage Life	at $175^{\circ}\text{C}$ for 1000 hrs.	MIL-STD-750D METHOD-1031