

**SN54HC640, SN54HC643, SN54HC645
SN74HC640, SN74HC643, SN74HC645
OCTAL BUS TRANSCEIVERS WITH 3-STATE OUTPUTS**

D2684, DECEMBER 1982 - REVISED JUNE 1989

- Choice of True or Inverting Logic
- High-Current 3-State Outputs Can Drive Up to 15 LSTTL Loads
- Package Options Include Plastic "Small Outline" Packages, Ceramic Chip Carriers, and Standard Plastic and Ceramic 300-mil DIPs
- Dependable Texas Instruments Quality and Reliability

DEVICE	LOGIC
'HC640	Inverting
'HC643	True and Inverting
'HC645	True

description

These octal bus transceivers are designed for asynchronous two-way communication between data buses. The devices transmit data from the A bus to the B bus or from the B bus to the A bus depending upon the level at the direction control (DIR) input. The enable input (\bar{G}) can be used to disable the device so the buses are effectively isolated.

The SN54HC640, SN54HC643, and SN54HC645 are characterized for operation over the full military temperature range of -55°C to 125°C . The SN74HC640, SN74HC643, and SN74HC645 are characterized for operation from -40°C to 85°C .

FUNCTION TABLE

CONTROL INPUTS		OPERATION		
		'HC640	'HC643	'HC645
\bar{G}	DIR			
L	L	\bar{B} data to A bus	B data to A bus	B data to A bus
L	H	\bar{A} data to B bus	\bar{A} data to B bus	A data to B bus
H	X	Isolation	Isolation	Isolation

SN54HC' . . . J PACKAGE
SN74HC' . . . DW OR N PACKAGE
(TOP VIEW)

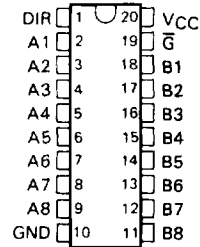

SN54HC' . . . FK PACKAGE
(TOP VIEW)

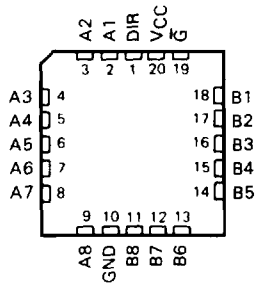

PRODUCTION DATA documents contain information current as of publication date. Products conform to specifications per the terms of Texas Instruments standard warranty. Production processing does not necessarily include testing of all parameters.



POST OFFICE BOX 655012 • DALLAS, TEXAS 75265

Copyright © 1989, Texas Instruments Incorporated

**SN54HC640, SN54HC643, SN54HC645
SN74HC640, SN74HC643, SN74HC645
OCTAL BUS TRANSCEIVERS WITH 3-STATE OUTPUTS**

logic symbols†

2
HCMS Devices

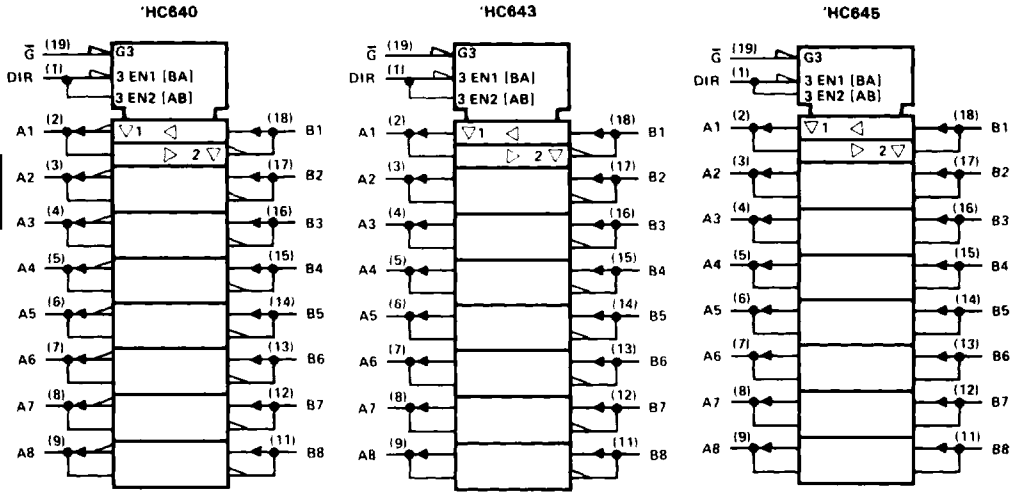

† These symbols are in accordance with ANSI/IEEE Std 91-1984 and IEC Publication 617-12.

logic diagrams (positive logic)

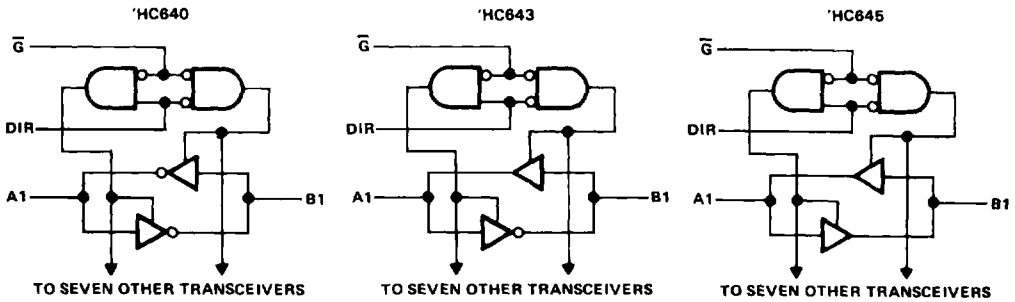

**SN54HC640, SN54HC643, SN54HC645
SN74HC640, SN74HC643, SN74HC645
OCTAL BUS TRANSCEIVERS WITH 3-STATE OUTPUTS**

absolute maximum ratings over operating free-air temperature range†

Supply voltage, V_{CC}	-0.5 V to 7 V
Input clamp current, I_{IK} ($V_I < 0$ or $V_I > V_{CC}$)	± 20 mA
Output clamp current, I_{OK} ($V_O < 0$ or $V_O > V_{CC}$)	± 20 mA
Continuous output current, I_O ($V_O = 0$ to V_{CC})	± 35 mA
Continuous current through V_{CC} or GND pins	± 70 mA
Lead temperature 1,6 mm (1/16 in) from case for 60 s: FK or J package	300°C
Lead temperature 1,6 mm (1/16 in) from case for 10 s: DW or N package	260°C
Storage temperature range	-65°C to 150°C

† Stresses beyond those listed under "absolute maximum ratings" may cause permanent damage to the device. These are stress ratings only, and functional operation of the device at these or any other conditions beyond those indicated under "recommended operating conditions" is not implied. Exposure to absolute-maximum-rated conditions for extended periods may affect device reliability.

recommended operating conditions

		SN54HC640 SN54HC643 SN54HC645			SN74HC640 SN74HC643 SN74HC645			UNIT
		MIN	NOM	MAX	MIN	NOM	MAX	
V_{CC} Supply voltage		2	5	6	2	5	6	V
V_{IH} High-level input voltage	$V_{CC} = 2$ V	1.5			1.5			V
	$V_{CC} = 4.5$ V	3.15			3.15			
	$V_{CC} = 6$ V	4.2			4.2			
V_{IL} Low-level input voltage	$V_{CC} = 2$ V	0	0.3		0	0.3		V
	$V_{CC} = 4.5$ V	0	0.9		0	0.9		
	$V_{CC} = 6$ V	0	1.2		0	1.2		
V_I Input voltage		0	V_{CC}		0	V_{CC}		V
V_O Output voltage		0	V_{CC}		0	V_{CC}		V
t_t Input transition (rise and fall) times	$V_{CC} = 2$ V	0	1000		0	1000		ns
	$V_{CC} = 4.5$ V	0	500		0	500		
	$V_{CC} = 6$ V	0	400		0	400		
T_A Operating free-air temperature		-55	125		-40	85		°C

electrical characteristics over recommended operating free-air temperature range (unless otherwise noted)

PARAMETER	TEST CONDITIONS	V_{CC}	$T_A = 25^\circ\text{C}$			SN54HC640 SN54HC643 SN54HC645		SN74HC640 SN74HC643 SN74HC645		UNIT
			MIN	TYP	MAX	MIN	MAX	MIN	MAX	
			V_{OH}	$V_I = V_{IH}$ or V_{IL} , $I_{OH} = -20 \mu\text{A}$	2 V	1.9	1.998		1.9	
4.5 V	4.4	4.499				4.4	4.4			
6 V	5.9	5.999				5.9	5.9			
$V_I = V_{IH}$ or V_{IL} , $I_{OH} = -6 \text{ mA}$	4.5 V	3.98		4.30		3.7	3.84			
V_{OL}	$V_I = V_{IH}$ or V_{IL} , $I_{OL} = 20 \mu\text{A}$	2 V		0.002	0.1		0.1	0.1	V	
		4.5 V		0.001	0.1		0.1	0.1		
		6 V		0.001	0.1		0.1	0.1		
	$V_I = V_{IH}$ or V_{IL} , $I_{OL} = 6 \text{ mA}$	4.5 V		0.17	0.26		0.4	0.33		
I_I	DIR or \bar{G}	$V_I = V_{CC}$ or 0	6 V	± 0.1	± 100		± 1000	± 1000	nA	
		$V_O = V_{CC}$ or 0	6 V	± 0.01	± 0.5		± 10	± 5	μA	
I_{CC}	A or B	$V_I = V_{CC}$ or 0, $I_O = 0$	6 V		8		160	80	μA	
C_i	DIR or \bar{G}		2 to 6 V	3	10		10	10	pF	



POST OFFICE BOX 655012 • DALLAS, TEXAS 75285

2-549

2
HCMOS Devices

SN54HC640, SN74HC640 OCTAL BUS TRANSCEIVERS WITH 3-STATE OUTPUTS

switching characteristics over recommended operating free-air temperature range (unless otherwise noted), $C_L = 50$ pF (see Note 1)

PARAMETER	FROM (INPUT)	TO (OUTPUT)	V _{CC}	T _A = 25°C			SN54HC640		SN74HC640		UNIT
				MIN	TYP	MAX	MIN	MAX	MIN	MAX	
t _{pd}	A or B	B or A	2 V		29	105		160		130	ns
			4.5 V		10	21		32		26	
			6 V		8	18		27		22	
t _{en}	G	A or B	2 V		109	230		340		290	ns
			4.5 V		27	46		68		58	
			6 V		20	39		58		49	
t _{dis}	G	A or B	2 V		40	150		225		190	ns
			4.5 V		18	30		45		38	
			6 V		16	26		38		32	
t _t		A or B	2 V		20	60		90		75	ns
			4.5 V		8	12		18		15	
			6 V		6	10		15		13	

C _{pd}	Power dissipation capacitance per transceiver	No load, T _A = 25°C	40 pF typ
-----------------	---	--------------------------------	-----------

switching characteristics over recommended operating free-air temperature range (unless otherwise noted), $C_L = 150$ pF (see Note 1)

PARAMETER	FROM (INPUT)	TO (OUTPUT)	V _{CC}	T _A = 25°C			SN54HC640		SN74HC640		UNIT
				MIN	TYP	MAX	MIN	MAX	MIN	MAX	
t _{pd}	A or B	B or A	2 V		44	190		290		235	ns
			4.5 V		14	38		58		47	
			6 V		11	33		49		41	
t _{en}	G	A or B	2 V		124	315		470		395	ns
			4.5 V		31	63		94		79	
			6 V		23	54		80		68	
t _t		A or B	2 V		45	210		315		265	ns
			4.5 V		17	42		63		53	
			6 V		13	36		53		45	

NOTE 1: Load circuit and voltage waveforms are shown in Section 1.

SN54HC643, SN74HC643 OCTAL BUS TRANSCEIVERS WITH 3-STATE OUTPUTS

switching characteristics over recommended operating free-air temperature range (unless otherwise noted), $C_L = 50$ pF (see Note 1)

PARAMETER	FROM (INPUT)	TO (OUTPUT)	V_{CC}	$T_A = 25^\circ\text{C}$			SN54HC643		SN74HC643		UNIT
				MIN	TYP	MAX	MIN	MAX	MIN	MAX	
t_{pd}	A or B	B or A	2 V		29	110		165		140	ns
			4.5 V		10	22		33		28	
			6 V		8	19		28		24	
t_{en}	\bar{G}	A or B	2 V		109	230		340		290	ns
			4.5 V		27	48		68		58	
			6 V		20	39		58		49	
t_{dis}	\bar{G}	A or B	2 V		40	150		225		190	ns
			4.5 V		18	30		45		38	
			6 V		16	26		38		32	
t_t		A or B	2 V		20	60		90		75	ns
			4.5 V		8	12		18		15	
			6 V		6	10		15		13	

C_{pd}	Power dissipation capacitance per transceiver	No load, $T_A = 25^\circ\text{C}$	40 pF typ
----------	---	-----------------------------------	-----------

switching characteristics over recommended operating free-air temperature range (unless otherwise noted), $C_L = 150$ pF (see Note 1)

PARAMETER	FROM (INPUT)	TO (OUTPUT)	V_{CC}	$T_A = 25^\circ\text{C}$			SN54HC643		SN74HC643		UNIT
				MIN	TYP	MAX	MIN	MAX	MIN	MAX	
t_{pd}	A or B	B or A	2 V		44	195		295		245	ns
			4.5 V		14	39		59		49	
			6 V		11	34		50		43	
t_{en}	\bar{G}	A or B	2 V		124	315		470		395	ns
			4.5 V		31	63		94		79	
			6 V		23	54		80		68	
t_t		A or B	2 V		45	210		315		265	ns
			4.5 V		17	42		63		53	
			6 V		13	36		53		45	

NOTE 1: Load circuit and voltage waveforms are shown in Section 1.

2

HC MOS Devices

SN54HC645, SN74HC645 OCTAL BUS TRANSCEIVERS WITH 3-STATE OUTPUTS

switching characteristics over recommended operating free-air temperature range (unless otherwise noted), $C_L = 50$ pF (see Note 1)

PARAMETER	FROM (INPUT)	TO (OUTPUT)	V _{CC}	T _A = 25°C			SN54HC645		SN74HC645		UNIT
				MIN	TYP	MAX	MIN	MAX	MIN	MAX	
t _{pd}	A or B	B or A	2 V	40	105		160		130	ns	
			4.5 V	15	21		32		26		
			6 V	12	18		27		22		
t _{en}	0	A or B	2 V	125	230		340		290	ns	
			4.5 V	23	46		68		58		
			6 V	20	39		58		49		
t _{dis}	0	A or B	2 V	74	200		300		250	ns	
			4.5 V	25	40		60		50		
			6 V	21	34		51		43		
t _t		A or B	2 V	20	60		90		75	ns	
			4.5 V	8	12		18		15		
			6 V	6	10		15		13		

C _{pd}	Power dissipation capacitance per transceiver	No load, T _A = 25°C	40 pF typ
-----------------	---	--------------------------------	-----------

switching characteristics over recommended operating free-air temperature range (unless otherwise noted), $C_L = 150$ pF (see Note 1)

PARAMETER	FROM (INPUT)	TO (OUTPUT)	V _{CC}	T _A = 25°C			SN54HC645		SN74HC645		UNIT
				MIN	TYP	MAX	MIN	MAX	MIN	MAX	
t _{pd}	A or B	B or A	2 V	54	135		200		170	ns	
			4.5 V	18	27		40		34		
			6 V	15	23		34		29		
t _{en}	0	A or B	2 V	150	270		405		335	ns	
			4.5 V	31	54		81		67		
			6 V	25	46		69		56		
t _t		A or B	2 V	45	210		315		265	ns	
			4.5 V	17	42		63		53		
			6 V	13	36		53		45		

NOTE 1: Load circuit and voltage waveforms are shown in Section 1.