



# 2.5 V to 5.0 V Micropower, Precision Shunt Mode Voltage References

PRELIMINARY TECHNICAL INFORMATION

AD1586/7/8/9

## FEATURES

- Shunt Reference (2.5V, 3V, 4.096V, 5V)
- Initial Accuracy: +/- 0.1% max
- Temperature Drift: +/- 50 ppm/°C max
- Wide Operating Range : 50µA to 10mA
- Dynamic Output Impedance : 0.5Ω max
- Wideband Noise (10Hz - 10kHz): 50µV<sub>RMS</sub>
- Operating Temperature Range: -40°C to 85°C
- Compact, Surface-Mount, SOT-23 package

## FUNCTIONAL BLOCK DIAGRAM

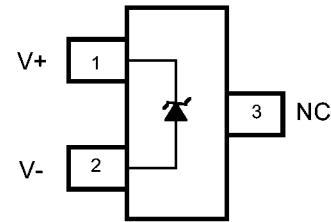

AD1586/7/8/9  
TOP VIEW

NC = NO CONNECT

## GENERAL DESCRIPTION

The AD1586, AD1587, AD1588, and AD1589 are a family of low cost, low power, precision bandgap references. They are available as two-terminal (shunt) devices and are packaged in the compact SOT-23. These references provide accurate output voltages for input currents between 50µA and 10mA.

The AD1586/7/8/9's superior accuracy and temperature stability are made possible by the precise matching and thermal tracking of on-chip components. Patented temperature drift curvature correction design techniques have been used to minimize the nonlinearities in the voltage output temperature characteristic.

The low minimum operating currents of the AD1586/7/8/9 make these references ideal for use in battery powered 3V or 5V systems, where there is a need to minimize power dissipation. With their wide input current ranges, however, these designs are extremely versatile and suitable for use in a variety of high current applications. In addition, their tiny packaging and inherent stability under all values of capacitive load, makes the AD1586/7/8/9 family of references ideal for space critical applications.

The AD1586, AD1587, AD1588, and AD1589, are available in two grades, A and B, both of which are provided in the smallest available package on the market, the SOT-23. Both grades are specified over the industrial temperature range of -40°C to +85°C.

## TARGET APPLICATIONS

- Portable, Battery-Powered Equipment: Notebook Computers, Cellular Phones, Pagers, PDA's, GPS's, and DMM's.
- Computer Workstations: Suitable for use with a wide range of video RAMDAC's.
- Smart Industrial Transmitters.
- PCMCIA Cards.
- Automotive.
- Hard Disk Drives.
- 3 V / 5 V 8-12 Bit Data Converters.

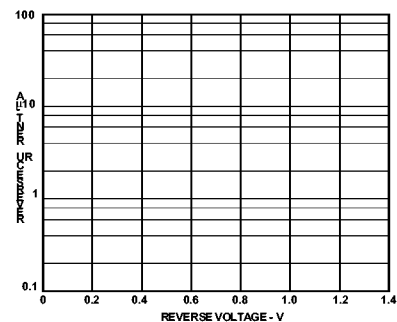

Reverse Voltage Temperature Drift Distribution

PRELIM. B, JUNE 96

Information furnished by Analog Devices is believed to be accurate and reliable. However, no responsibility is assumed by Analog Devices for its use, nor for any infringements of patents or other rights of third parties which may result from its use. No license is granted by implication or otherwise under any patent or patent rights of Analog Devices.

One Technology Way, P.O. Box 9106, Norwood, MA 02062-9106, U.S.A.  
Tel: 617/329-4700 Fax: 617/326-8703

# AD1586—SPECIFICATIONS

(@  $T_A = T_{MIN} - T_{MAX}$ ,  $V_N = 5\text{ V}$ , unless otherwise noted)

Model	AD1586A			AD1586B			Units
	Min	Typ	Max	Min	Typ	Max	
Reverse Voltage Output (@ +25°C)	2.48	2.50	2.52	2.498	2.500	2.502	V
Reverse Voltage Temperature Drift <sup>1</sup>			100			50	ppm/°C
Minimum Operating Current, $T_{MIN}$ to $T_{MAX}$			50			50	μA
Reverse Voltage Change With Reverse Current 50μA < $I_{IN}$ < 10 mA, $T_{MIN}$ to $T_{MAX}$ 50μA < $I_{IN}$ < 1 mA, $T_{MIN}$ to $T_{MAX}$		3	6 1		3 6 1		mV mV
Dynamic Output Impedance ( $\Delta V_R / \Delta I_R$ ) $I_{IN} = 1\text{ mA} \pm 100\ \mu\text{A}$ ( $f = 120\ \text{Hz}$ )		0.4	1		0.4	0.5	Ω
Noise Voltage 0.1 Hz to 10 Hz 10 Hz to 10 kHz		30 50			30 50		μV <sub>P-P</sub> μV <sub>RMS</sub>
Turn-On Settling Time to 0.1% <sup>2</sup>			25			25	μS
Long Term Stability 1000 hrs. @ +25°C			100			100	ppm/1000 hrs
Output Voltage Hysteresis <sup>3</sup>			TBD			TBD	μV
Temperature Range Specified Performance (A, B) Operating Performance (A, B) <sup>4</sup>	-40 -55		+85 +125	-40 -55		+85 +125	°C °C

## NOTES

<sup>1</sup>Maximum output voltage drift is guaranteed for all grades.

<sup>2</sup>Measured with no capacitance load.

<sup>3</sup>Hysteresis is defined as the change in the 25°C output voltage, caused by bringing the device to +85°C, taking a 25°C measurement, and then bringing it to -40°C, followed by another 25°C measurement.

<sup>4</sup>The operating temperature range is defined as the temperature extremes at which the device will still function. Parts may deviate from their specified performance outside the specified temperature range.

Specifications subject to change without notice.

# AD1587—SPECIFICATIONS (@ $T_A = T_{MIN} - T_{MAX}$ , $V_N = 5$ V, unless otherwise noted)

Model	AD1587A			AD1587B			Units
	Min	Typ	Max	Min	Typ	Max	
Reverse Voltage Output (@ +25°C)	2.97	3.00	3.03	2.997	3.000	3.003	V
Reverse Voltage Temperature Drift <sup>1</sup>			100			50	ppm/°C
Minimum Operating Current, $T_{MIN}$ to $T_{MAX}$			50			50	μA
Reverse Voltage Change With Reverse Current 50μA < $I_{IN}$ < 10 mA, $T_{MIN}$ to $T_{MAX}$ 50μA < $I_{IN}$ < 1 mA, $T_{MIN}$ to $T_{MAX}$		3.3	6.6 1		3.3 1	6.6 1	mV mV
Dynamic Output Impedance ( $\Delta V_R / \Delta I_R$ ) $I_{IN} = 1$ mA +/- 100 μA (f = 120 Hz)		0.4	1		0.4	0.5	Ω
Noise Voltage 0.1 Hz to 10 Hz 10 Hz to 10 kHz		30 60			30 60		μV <sub>P-P</sub> μV <sub>RMS</sub>
Turn-On Settling Time to 0.1% <sup>2</sup>			25			25	μS
Long Term Stability 1000 hrs. @ +25°C			100			100	ppm/1000 hrs
Output Voltage Hysteresis <sup>3</sup>			TBD			TBD	μV
Temperature Range Specified Performance (A, B) Operating Performance (A, B) <sup>4</sup>	-40 -55		+85 +125	-40 -55		+85 +125	°C °C

## NOTES

<sup>1</sup>Maximum output voltage drift is guaranteed for all grades.

<sup>2</sup>Measured with no capacitance load.

<sup>3</sup>Hysteresis is defined as the change in the 25°C output voltage, caused by bringing the device to +85°C, taking a 25°C measurement, and then bringing it to -40°C, followed by another 25°C measurement.

<sup>4</sup>The operating temperature range is defined as the temperature extremes at which the device will still function. Parts may deviate from their specified performance outside the specified temperature range.

Specifications subject to change without notice.

# AD1588—SPECIFICATIONS

(@  $T_A = T_{MIN} - T_{MAX}$ ,  $V_N = 5$  V, unless otherwise noted)

Model	AD1588A			AD1588B			Units
	Min	Typ	Max	Min	Typ	Max	
Reverse Voltage Output (@ +25°C)	4.055	4.096	4.137	4.092	4.096	4.100	V
Reverse Voltage Temperature Drift <sup>1</sup>			100			50	ppm/°C
Minimum Operating Current, $T_{MIN}$ to $T_{MAX}$			50			50	μA
Reverse Voltage Change With Reverse Current 50μA < $I_{IN}$ < 10 mA, $T_{MIN}$ to $T_{MAX}$ 50μA < $I_{IN}$ < 1 mA, $T_{MIN}$ to $T_{MAX}$		3.9	7.8 1		3.9	7.8 1	mV mV
Dynamic Output Impedance ( $\Delta V_R / \Delta I_R$ ) $I_{IN} = 1$ mA +/- 100 μA (f = 120 Hz)		0.4	1		0.4	0.5	Ω
Noise Voltage 0.1 Hz to 10 Hz 10 Hz to 10 kHz		50 90			50 90		μV <sub>P-P</sub> μV <sub>RMS</sub>
Turn-On Settling Time to 0.1% <sup>2</sup>			25			25	μS
Long Term Stability 1000 hrs.@ +25°C			100			100	ppm/1000 hrs
Output Voltage Hysteresis <sup>3</sup>			TBD			TBD	μV
Temperature Range Specified Performance (A, B) Operating Performance (A, B) <sup>4</sup>	-40 -55		+85 +125	-40 -55		+85 +125	°C °C

## NOTES

<sup>1</sup>Maximum output voltage drift is guaranteed for all grades.

<sup>2</sup>Measured with no capacitance load.

<sup>3</sup>Hysteresis is defined as the change in the 25°C output voltage, caused by bringing the device to +85°C, taking a 25°C measurement, and then bringing it to -40°C, followed by another 25°C measurement.

<sup>4</sup>The operating temperature range is defined as the temperature extremes at which the device will still function. Parts may deviate from their specified performance outside the specified temperature range.

Specifications subject to change without notice.

# AD1589—SPECIFICATIONS

(@  $T_A = T_{MIN} - T_{MAX}$ ,  $V_{IN} = 6\text{ V}$ , unless otherwise noted)

Model	AD1589A			AD1589B			Units
	Min	Typ	Max	Min	Typ	Max	
Reverse Voltage Output (@ +25°C)	4.95	5.00	5.05	4.995	5.000	5.005	V
Reverse Voltage Temperature Drift <sup>1</sup>			100			50	ppm/°C
Minimum Operating Current, $T_{MIN}$ to $T_{MAX}$			50			50	μA
Reverse Voltage Change With Reverse Current 50μA < $I_{IN}$ < 10 mA, $T_{MIN}$ to $T_{MAX}$ 50μA < $I_{IN}$ < 1 mA, $T_{MIN}$ to $T_{MAX}$		4.5	9	4.5	9	1	mV mV
Dynamic Output Impedance ( $\Delta V_R/\Delta I_R$ ) $I_{IN} = 1\text{ mA} \pm 100\ \mu\text{A}$ ( $f = 120\ \text{Hz}$ )		0.4	1	0.4	0.5		Ω
Noise Voltage 0.1 Hz to 10 Hz 10 Hz to 10 kHz		50 100		50 100			μV <sub>P-P</sub> μV <sub>RMS</sub>
Turn-On Settling Time to 0.1% <sup>2</sup>			25			25	μS
Long Term Stability 1000 hrs. @ +25°C			100			100	ppm/1000 hrs
Output Voltage Hysteresis <sup>3</sup>			TBD			TBD	μV
Temperature Range Specified Performance (A, B) Operating Performance (A, B) <sup>4</sup>	-40 -55		+85 +125	-40 -55		+85 +125	°C °C

## NOTES

<sup>1</sup>Maximum output voltage drift is guaranteed for all grades.

<sup>2</sup>Measured with no capacitance load.

<sup>3</sup>Hysteresis is defined as the change in the 25°C output voltage, caused by bringing the device to +85°C, taking a 25°C measurement, and then bringing it to -40°C, followed by another 25°C measurement.

<sup>4</sup>The operating temperature range is defined as the temperature extremes at which the device will still function. Parts may deviate from their specified performance outside the specified temperature range.

Specifications subject to change without notice.

# AD1586/7/8/9

## ABSOLUTE MAXIMUM RATINGS<sup>1</sup>

V <sub>IN</sub> to Ground	12 V
Internal Power Dissipation <sup>2</sup>	
SOT-23 (RT)	TBD
Storage Temperature Range	-65°C to +125°C
Operating Temperature Range	
AD 1586/7/8/9BRT	-40°C to +85°C
Lead Temperature, Soldering	
Vapor Phase (60 sec)	+215°C
Infrared (15 sec)	+220°C
ESD Susceptibility <sup>3</sup>	
Human Body Model	4 kV
Machine Model	400 V

## NOTES

<sup>1</sup>Stresses above those listed under "Absolute Maximum Ratings" may cause permanent damage to the device. This is a stress rating only and functional operation of the device at these or any other conditions above those indicated in the operational section of this specification is not implied. Exposure to absolute maximum rating conditions for extended periods may affect device reliability.

<sup>2</sup>Specification is for device in free air at 25°C; SOT-23 Package:  $\theta_{JA}$  = 300°C/Watt.

<sup>3</sup>The human body model is a 100 pF capacitor discharged through 1.5 k $\Omega$ . For the machine model, a 200 pF capacitor is discharged directly into the device.

## ORDERING GUIDE

Model*	Initial Output Accuracy	Temperature Coefficient
AD 1586/7/8/9ART	1%	100 ppm/°C
AD 1586/7/8/9ART-REEL <sup>1</sup>	1%	100 ppm/°C
AD 1586/7/8/9ART-REEL <sup>2</sup>	1%	100 ppm/°C
AD 1586/7/8/9BRT	0.1%	50 ppm/°C
AD 1586/7/8/9BRT-REEL <sup>1</sup>	0.1%	50 ppm/°C
AD 1586/7/8/9BRT-REEL <sup>2</sup>	0.1%	50 ppm/°C

## NOTES

\*Package Option for all Models; RT = SOT-23

<sup>1</sup>Provided on a 13 inch reel containing 7,000 pieces.

<sup>2</sup>Provided on a 7 inch reel containing 2,000 pieces.

## AD1586/7/8/9 PACKAGE BRANDING INFORMATION

Four marking fields identify the device generic, grade, and date of processing. The first field is the product identifier. A "6/7/8/9" identifies the generic as the AD 1586/7/8/9. The second field indicates the device grade; "A" or "B". In the third field a numeral or letter indicates the calendar year; "5" for 1995..., "A" for 2001... The fourth field uses letters A-Z to represent a two week window within the calendar year; starting with "A" for the first two weeks of January.

## OUTLINE DIMENSIONS

Dimensions shown in inches and (mm).

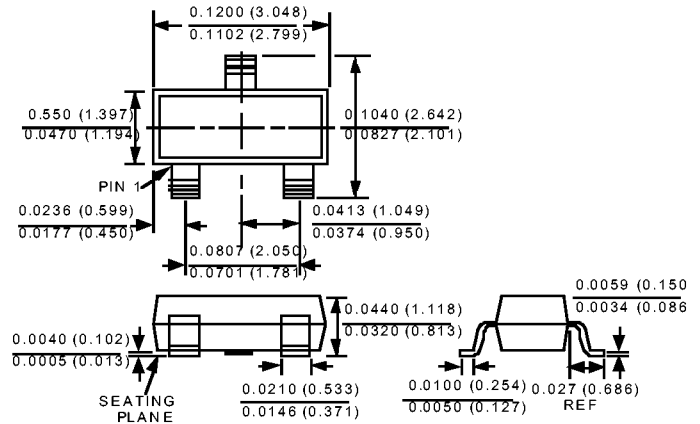

## TAPE AND REEL DIMENSIONS

Dimensions shown in millimeters.

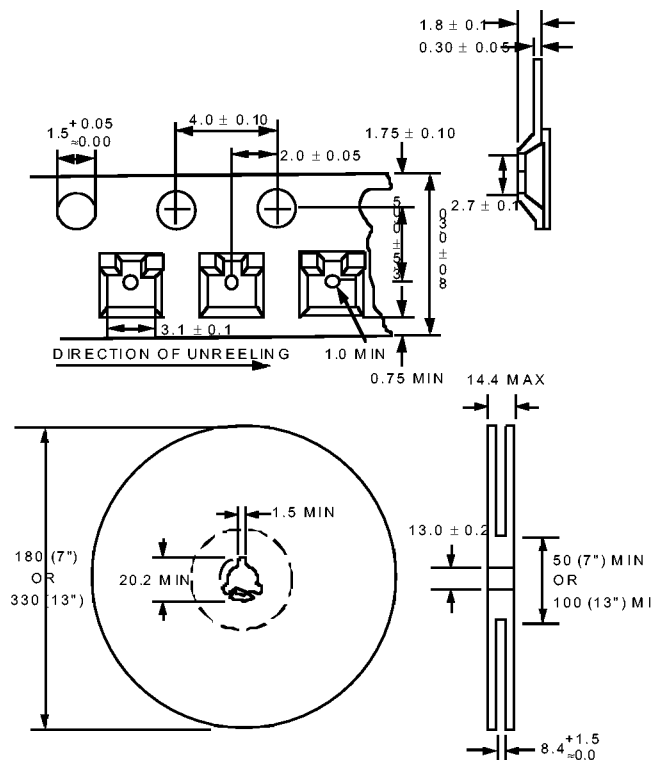

## CAUTION

ESD (electrostatic discharge) sensitive device. Electrostatic charges as high as 4000 V readily accumulate on the human body and test equipment and can discharge without detection. Although the AD 1586/7/8/9 features proprietary ESD protection circuitry, permanent damage may occur on devices subjected to high energy electrostatic discharges. Therefore, proper ESD precautions are recommended to avoid performance degradation or loss of functionality.



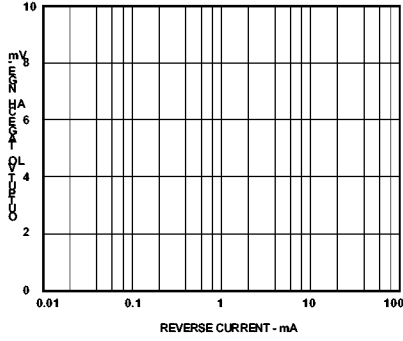

Figure 1. Reverse Voltage Error Distribution

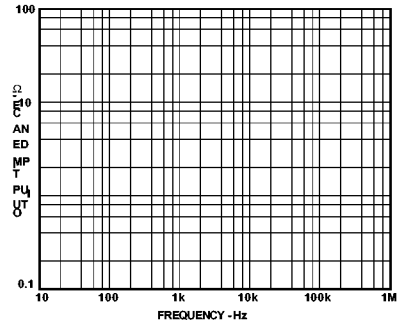

Figure 4. Output Voltage Error vs. Reverse Current

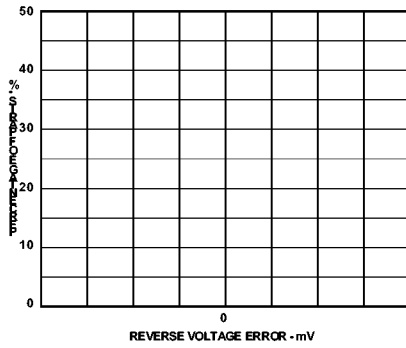

Figure 2. Output Drift for Different Temperature Characteristics

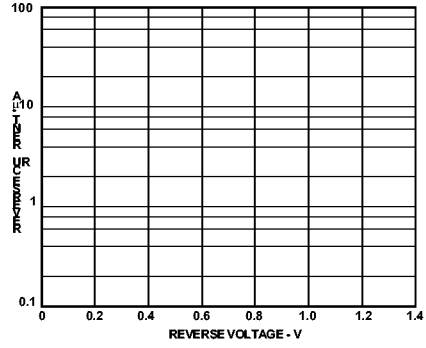

Figure 5. Reverse Current vs. Reverse Voltage

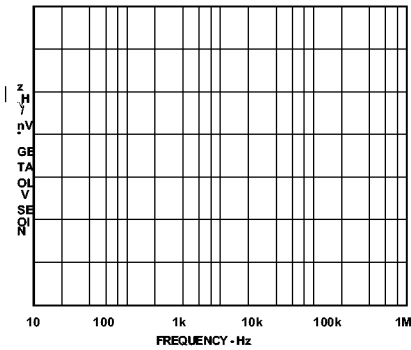

Figure 3. Noise-Spectral Density

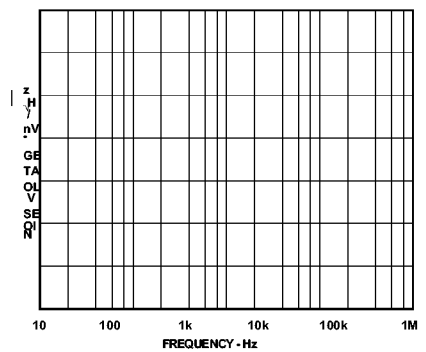

Figure 6. Forward Voltage vs. Forward Current

# AD1586/7/8/9

## THEORY OF OPERATION

The AD1586/7/8/9 family uses the "bandgap" concept to produce stable, low-temperature coefficient voltage references which are suitable for high accuracy data-acquisition components and systems. This family of precision references makes use of the underlying temperature characteristics of a silicon transistor's base-emitter voltage in the forward-biased operating region. Under this condition, all such transistors have a  $-2 \text{ mV}/^\circ\text{C}$  temperature coefficient (TC) and a  $V_{BE}$  that, when extrapolated to absolute zero,  $0 \text{ }^\circ\text{K}$ , (with collector current proportional to absolute temperature) approximates the silicon bandgap voltage. By summing a voltage that has an equal and opposite temperature coefficient of  $+2 \text{ mV}/^\circ\text{C}$  with the  $V_{BE}$  of a forward-biased transistor, a zero TC reference can be developed. In the AD1586/7/8/9 simplified circuit diagram shown in Figure 7, such a compensating voltage,  $V_1$ , is derived by driving two transistors at different current densities and amplifying the resultant  $V_{BE}$  difference ( $\Delta V_{BE}$  - which has a positive TC). The sum ( $V_{BG}$ ) of  $V_{BE}$  and  $V_1$  is then scaled by the  $R_5/R_6$  resistor network to produce stable reference voltage outputs of 2.5V, 3V, 4.096V, and 5V. To ensure that the bandgap cell and resistor network maintain their required current levels, a buffer amplifier drives an output transistor to sink any excess current.

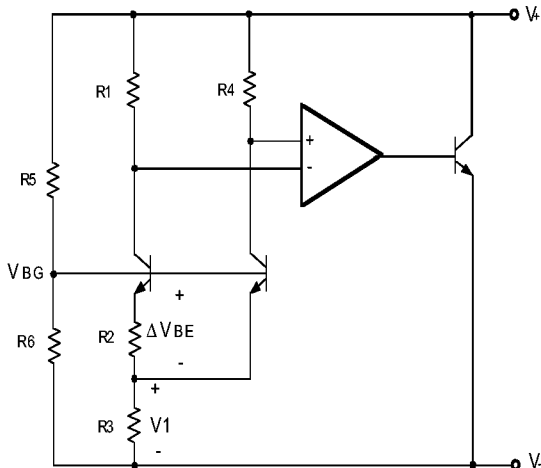

Figure 7. AD1586/7/8/9 Simplified Schematic

## APPLYING THE AD1586

The AD1586/7/8/9 family of shunt references are simple to use in virtually all applications. To operate the AD1586/7/8/9 family as conventional shunt regulators (Figure 8a), an external series resistor is connected between the supply voltage and the reference. For a given supply voltage the series resistor,  $R_S$ , determines the reverse current flowing through the AD1586/7/8/9. The value of  $R_S$  must be chosen to maintain an acceptable reverse current,  $I_R$ , while accommodating the expected variations of the supply voltage,  $V_S$ , load current,  $I_L$ , and the reverse voltage,  $V_R$ .

The minimum value for  $R_S$  should then be chosen when  $I_L$  and  $V_R$  are at their maximum and  $V_S$  is at its minimum.

For the AD1586/7/8/9 family, the value of  $R_S$  should be large enough to limit  $I_R$  to 10mA when  $V_S$  is at its maximum and  $I_L$  and  $V_R$  are at their minimum.

The equations for selecting  $R_S$  is as follows:

$$R_S = (V_S - V_R) / (I_R + I_L)$$

Figure 8b shows a typical connection with the AD1586BRT shunt reference. In this circuit,  $R_S$  is chosen for operation with a minimum of  $100 \mu\text{A}$  quiescent current, a  $+1 \text{ mA}$  load current and a power supply tolerance of  $\pm 10 \%$ .

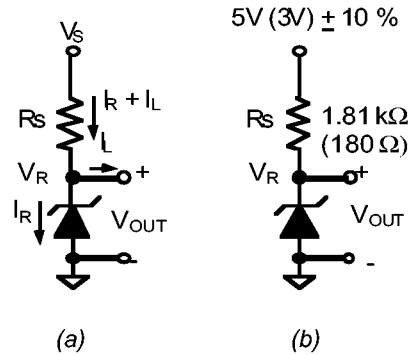

Figure 8. Typical Connection Diagram

## TEMPERATURE PERFORMANCE

The AD1586/7/8/9 family of references are designed for applications where temperature performance is important. Extensive temperature testing and characterization ensures that the device's performance is maintained over the specified temperature range.

Some confusion exists, however, in the area of defining and specifying reference voltage error over temperature. Historically, references have been characterized using a maximum deviation per degree centigrade, i.e.,  $50 \text{ ppm}/^\circ\text{C}$ . However, because of the inconsistent nonlinearities in standard zener references (such as "S" type characteristics), most manufacturers use a maximum limit error band approach to characterize their references. Using this technique, the voltage reference output voltage error band is specified by taking output voltage measurements at three or more different temperatures.

The error band which is guaranteed with the AD1586/7/8/9 family is the maximum deviation from the initial value at  $+25^\circ\text{C}$ ; this method is of more use to a designer than the one which simply guarantees the maximum error band over the entire temperature change. Thus, for a given grade of the AD1586/7/8/9, the designer can easily determine the maximum total error from initial accuracy plus temperature variation (e.g., for the AD1586BRT, the initial tolerance is  $\pm 2 \text{ mV}$ , the temperature error band is  $\pm 8 \text{ mV}$ , thus the reference is guaranteed to be  $2.5 \text{ V} \pm 10 \text{ mV}$  from  $-40^\circ\text{C}$  to  $+85^\circ\text{C}$ ).

Figure 9 shows the typical output voltage drift for the AD1586 and illustrates the methodology. The box in Figure 9 is bounded on the x-axis by operating temperature extremes, and on the y-axis by the maximum and minimum output voltages observed over the operating temperature range. The slope of the diagonal drawn from the initial output value at  $+25^\circ\text{C}$  to the output values at  $+85^\circ\text{C}$  and  $-40^\circ\text{C}$  determines the performance grade of the device.

Duplication of these results requires a test system that is highly accurate with stable temperature control. Evaluation of the AD1586 will produce curves similar to those in Figures 3 and 9, but output readings may vary depending upon the test methods and test equipment utilized.



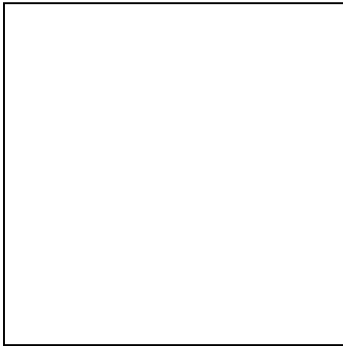

Figure 9. Output Voltage vs. Temperature

**VOLTAGE OUTPUT NONLINEARITY VERSUS TEMPERATURE**

When using a voltage reference with data converters it is important to understand the impact that temperature drift can have on the converter's performance. The nonlinearity of the reference output drift represents additional error that can not easily be calibrated out of the overall system. To better understand the impact that such a drift can have on a data converter refer to figure 10 where the measured drift characteristic is normalized to the end point average drift. The residual drift error of the AD1586 of approximately XXX ppm demonstrates that this family of references is compatible with systems that require XX-bit accurate temperature performance.

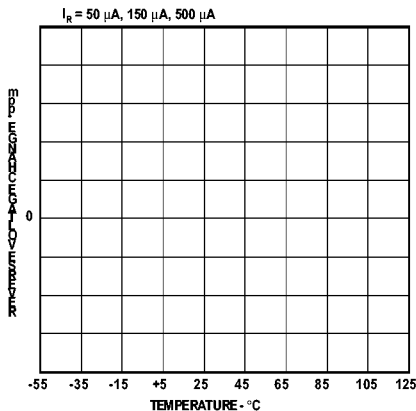

Figure 10. Residual Drift Error

**REVERSE VOLTAGE HYSTERESIS**

High performance industrial equipment manufacturers require the AD1586/7/8/9 family to maintain consistent output voltage errors at +25°C after the references are operated over the full temperature range. While all references exhibit a characteristic known as output voltage hysteresis, the AD1586/7/8/9 family is designed to minimize this characteristic. This phenomena can be quantified by measuring the change in the +25°C output voltage after temperature excursions from +85°C to +25°C, and -40°C to +25°C. Figure 11 displays the distribution over 100 parts of the AD1586 output voltage hysteresis.

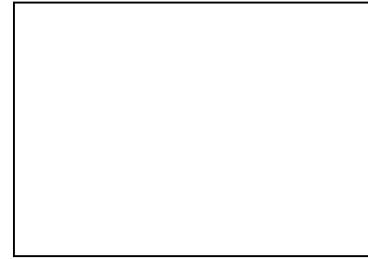

Figure 11. Output Voltage Hysteresis Distribution

**AC PERFORMANCE**

To successfully apply the AD1586/7/8/9 family of references, it is important to understand the effects of the dynamic output impedance. In Figure 12a, a voltage divider is formed by the AD1586's output impedance and the external source impedance. When using an external source resistor of approximately 25 kΩ ( $I_R = 100 \mu A$ ), X% of the noise from a 100 kHz switching power supply is developed at the reference output. Figure 12b shows the effect that varying the load capacitor on the reference output has on the AD1586 noise performance. From this graph it is apparent that a 1 μF capacitor connected to the AD1586 output will reduce the effect of power supply noise to less than X.XX%.

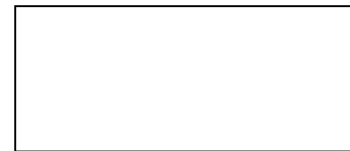

Figure 12a. Output Impedance Test Circuit

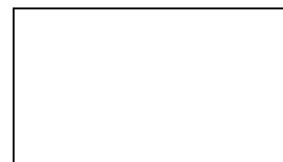

Figure 12b. Output Impedance vs. Frequency

## NOISE PERFORMANCE AND REDUCTION

The noise generated by the AD1586 is typically less than  $30\ \mu\text{V}$  pk-pk over the 0.1 Hz to 10 Hz frequency band. Figure 13 shows the 0.1 Hz to 10 Hz noise of a typical AD1586. The noise measurement is made with a high gain bandpass filter. Noise in a 10 Hz to 10 kHz region is approximately  $50\ \mu\text{V}$  rms. Figure 14 shows the broadband noise of a typical AD1586. If further noise reduction is desired, a 1-pole low pass filter may be added between the output pin and ground. A time constant of X.X ms will have a -3 dB point at roughly 800 Hz and will reduce the high frequency noise to about X.X  $\mu\text{V}$  rms.



Figure 13. 0.1 - 10 Hz Voltage Noise

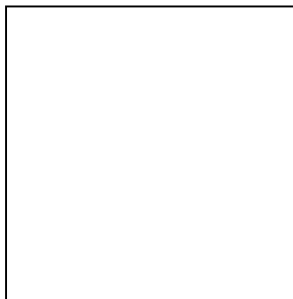

Figure 14. 10 Hz to 10 kHz RMS Noise

## TURN-ON TIME

Many low power instrument manufacturers are becoming increasingly concerned with the turn-on characteristics of the components being used in their systems. Fast turn-on components often enable the end user to save power by keeping power off when it is not needed. Turn-on settling time is defined as the time required, after the application of power (cold start), for the output voltage to reach its final value within a specified error. The two major factors that affect this are the active circuit settling time and the time required for the thermal gradients on the chip to stabilize. Figure 15a shows the turn-on settling and transient response test circuit. Figure 15b displays the turn-on characteristic of the AD1586. This characteristic is generated from cold-start operation and represents the true turn-on waveform after power up. Figure 15c shows the fine settling characteristics of the AD1586. Typically, the reference settles to within 0.1% of its final value in about 25  $\mu\text{s}$ .

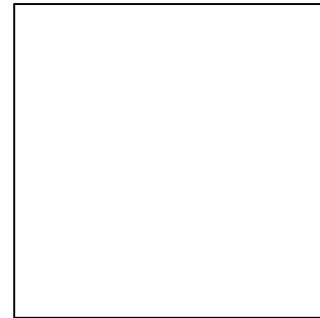

Figure 15a. Turn-On / Transient Response Test Circuit



Figure 15b. Turn-On Characteristics

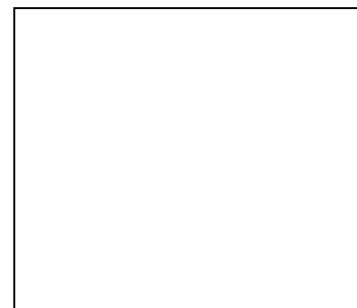

Figure 15c. Turn-On Settling

## DYNAMIC PERFORMANCE

Many A/D and D/A converters present transient current loads to the reference, and poor reference response can degrade the converter's performance.

Figure 16 displays both the coarse and fine settling characteristics of the AD1586 to load transients of  $\pm 50\ \mu\text{A}$ . The circuit used to perform such measurements is displayed in Figure 15a, where the input supply voltage is toggled from 3V to 5V ( $+50\ \mu\text{A}$ ) and 5V to 3V ( $-50\ \mu\text{A}$ ).

Figure 16a shows the settling characteristics of the device for an increased reverse current of  $50\ \mu\text{A}$ . Figure 16b shows the settling characteristics when the reverse current is decreased by  $50\ \mu\text{A}$ . In both cases, the transients settle to within 1 mV in approximately X  $\mu\text{s}$ .

Attempts to drive large capacitive loads (in excess of 1,000 pF) with the AD1586/7/8/9 family may result in the ringing shown in Figure 17. This is due to the additional poles formed by the load capacitor and the output impedance of the reference. A recommended method of driving capacitive loads of this magnitude is shown in Figure 15a. Here, the resistor isolates the capacitive load from the output stage, while the capacitor provides a single pole low pass filter that lowers the output noise.

APPLICATIONS INFORMATION

**BUFFERED MICRO POWER 2.5V REFERENCE PROVIDING  
100MA OUTPUT**



*Figure 21. Precision Buffered Circuit*

**LOW POWER, 2.5V REFERENCE FOR SINGLE SUPPLY  
MULTIPLYING DACS**



*Figure 22. Using the AD1586 with Single Supply DACS*