



PRELIMINARY

**CY7C1380C**  
**CY7C1382C**

**512K x 36 / 1M x 18 Pipelined SRAM**

**Features**

- Fast clock speed: 250, 225, 200, 167 MHz
- Provide high-performance 3-1-1-1 access rate
- Fast OE access times: 2.6, 2.8, 3.0, 3.4 ns
- Optimal for depth expansion
- 3.3V (-5% / +10%) power supply
- Separate V<sub>DDQ</sub> for 3.3V or 2.5V I/O
- Common data inputs and data outputs
- Byte Write Enable and Global Write control
- Chip enable for address pipeline
- Address, data, and control registers
- Internally self-timed Write Cycle
- Burst control pins (interleaved or linear burst sequence)
- Automatic power-down available using ZZ mode or CE deselect
- High-density, high-speed packages
- Available in 119-ball bump BGA, 165-ball FBGA and 100-pin TQFP packages
- JTAG boundary scan for BGA packaging version

**Functional Description**

The Cypress Synchronous Burst SRAM family employs high-speed, low-power CMOS designs using advanced single-layer polysilicon, triple-layer metal technology. Each memory cell consists of six transistors.

The CY7C1380C and CY7C1382C SRAMs integrate 524,288x36 and 1,048,576x18 SRAM cells with advanced

synchronous peripheral circuitry and a 2-bit counter for internal burst operation. All synchronous inputs are gated by registers controlled by a positive-edge-triggered Clock Input (CLK). The synchronous inputs include all addresses, all data inputs, address-pipelining Chip Enable (CE), burst control inputs (ADSC, ADSP, and ADV), write enables (BW<sub>a</sub>, BW<sub>b</sub>, BW<sub>c</sub>, BW<sub>d</sub> and BWE), and Global Write (GW).

Asynchronous inputs include the Output Enable ( $\overline{OE}$ ) and burst mode control (MODE). DQ<sub>a,b,c,d</sub> and DP<sub>a,b,c,d</sub> apply to CY7C1380B and DQ<sub>a,b</sub> and DP<sub>a,b</sub> apply to CY7C1382B. a, b, c, d each are 8 bits wide in the case of DQ and 1 bit wide in the case of DP.

Addresses and chip enables are registered with either Address Status Processor (ADSP) or Address Status Controller (ADSC) input pins. Subsequent burst addresses can be internally generated as controlled by the Burst Advance Pin (ADV).

Address, data inputs, and write controls are registered on-chip to initiate a self-timed Write cycle. Write cycles can be one to four bytes wide, as controlled by the write control inputs. Individual byte writes allow individual bytes to be written. BW<sub>a</sub> controls DQ<sub>a</sub> and DP<sub>a</sub>. BW<sub>b</sub> controls DQ<sub>b</sub> and DP<sub>b</sub>. BW<sub>c</sub> controls DQ<sub>c</sub> and DP<sub>c</sub>. BW<sub>d</sub> controls DQ<sub>d</sub> and DP<sub>d</sub>. BW<sub>a</sub>, BW<sub>b</sub>, BW<sub>c</sub>, and BW<sub>d</sub> can be active only with BWE being LOW. GW being LOW causes all bytes to be written. Write pass-through capability allows written data available at the output for the next Read cycle. This device also incorporates pipelined enable circuit for easy depth expansion without penalizing system performance.

All inputs and outputs of the CY7C1380C and the CY7C1382C are JEDEC standard JESD8-5 compatible.

**Selection Guide**

	250 MHz	225 MHz	200 MHz	167 MHz	Unit
Maximum Access Time	2.6	2.8	3.0	3.4	ns
Maximum Operating Current	350	325	300	275	mA
Maximum CMOS Standby Current	70	70	70	70	mA

Shaded areas contain advance information.

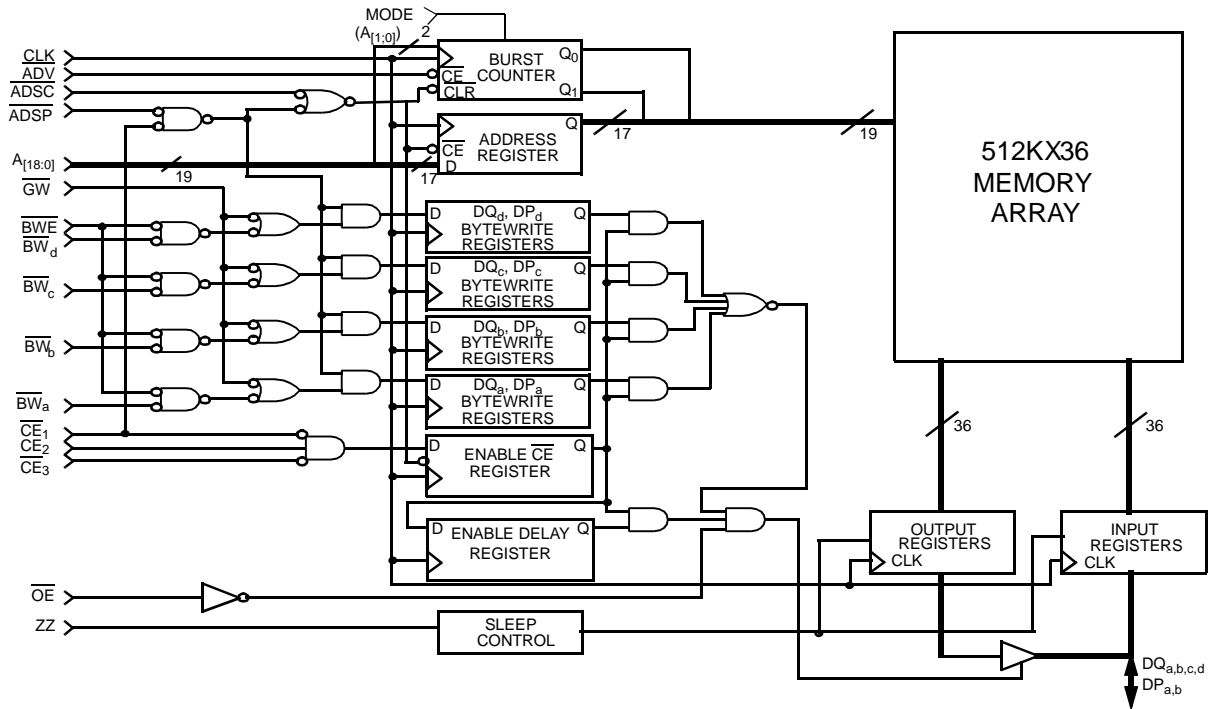
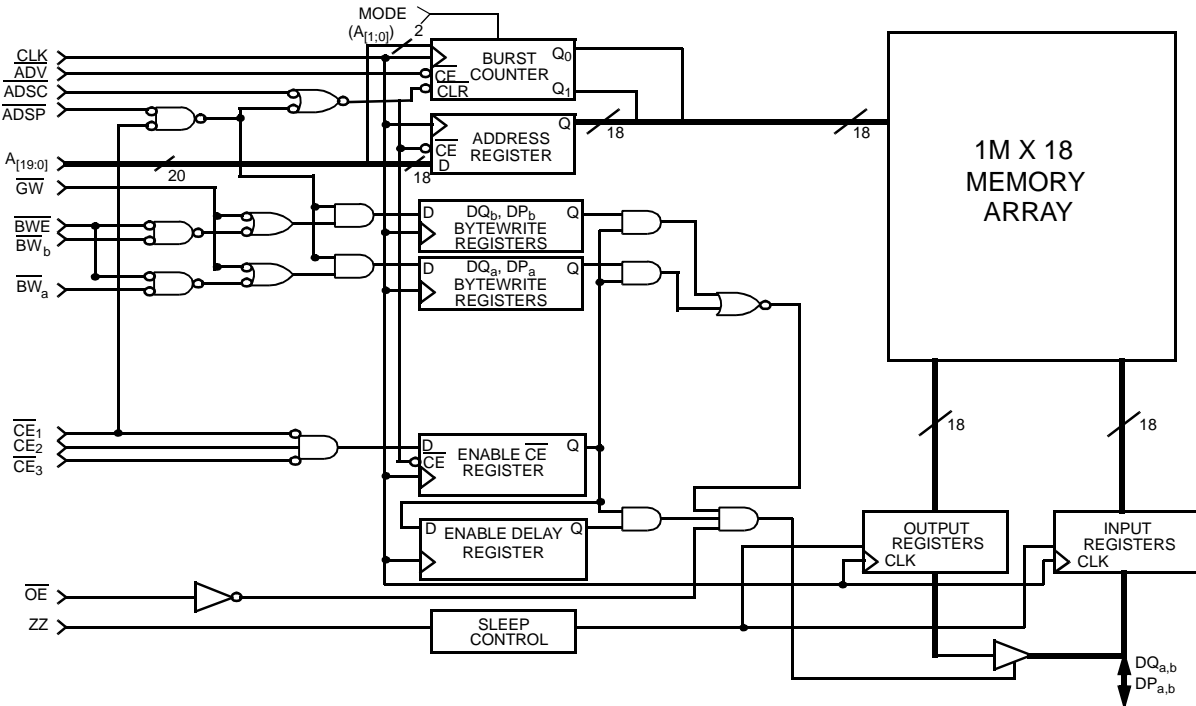
**Logic Block Diagram CY7C1380C - 512K x 36**

**Logic Block Diagram CY7C1382C - 1M X 18**

Pin Configurations

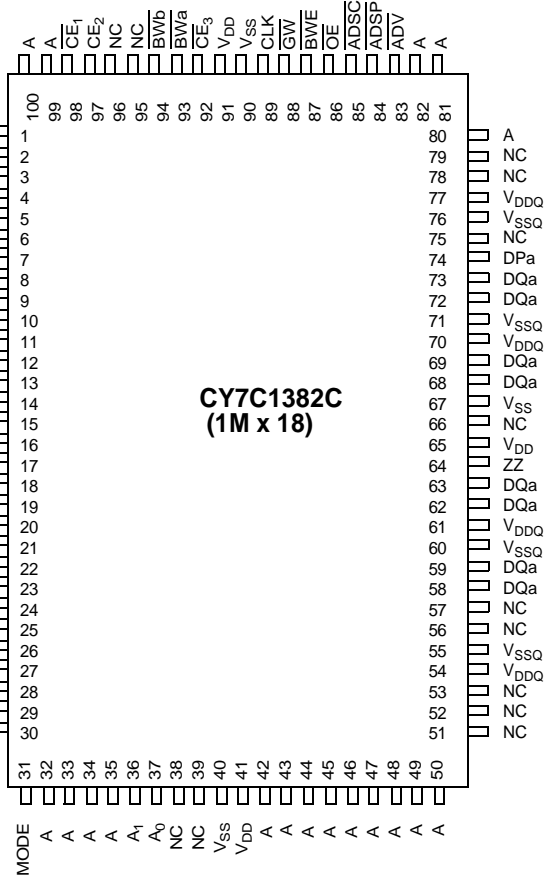
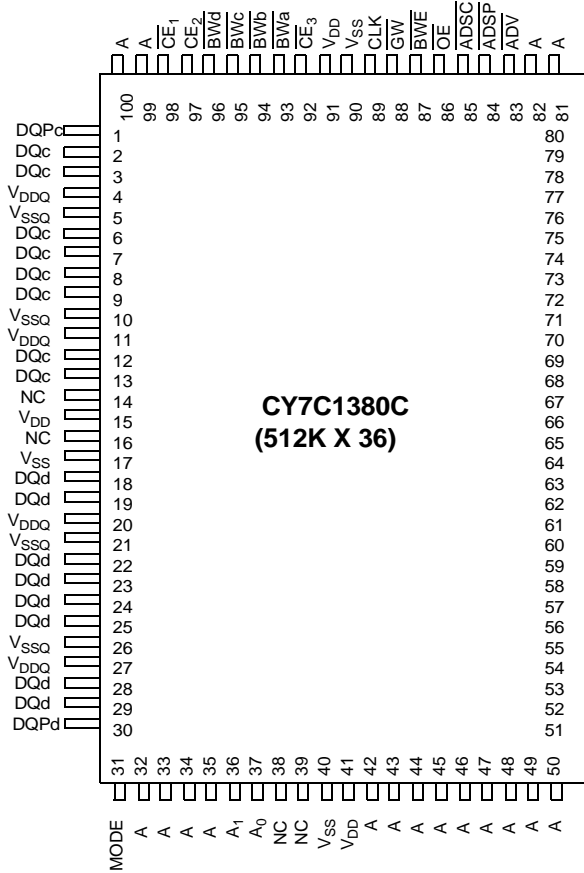
100-Pin TQFP  
(Top View)



**Pin Configurations** (continued)

**CY7C1380C (512K x 36)**

	1	2	3	4	5	6	7
<b>A</b>	V <sub>DDQ</sub>	A	A	$\overline{\text{ADSP}}$	A	A	V <sub>DDQ</sub>
<b>B</b>	NC	A	A	$\overline{\text{ADSC}}$	A	A	NC
<b>C</b>	NC	A	A	V <sub>DD</sub>	A	A	NC
<b>D</b>	DQc	DPc	V <sub>SS</sub>	NC	V <sub>SS</sub>	DPb	DQb
<b>E</b>	DQc	DQc	V <sub>SS</sub>	$\overline{\text{CE}}_1$	V <sub>SS</sub>	DQb	DQb
<b>F</b>	V <sub>DDQ</sub>	DQc	V <sub>SS</sub>	$\overline{\text{OE}}$	V <sub>SS</sub>	DQb	V <sub>DDQ</sub>
<b>G</b>	DQc	DQc	$\overline{\text{BWc}}$	$\overline{\text{ADV}}$	$\overline{\text{BWb}}$	DQb	DQb
<b>H</b>	DQc	DQc	V <sub>SS</sub>	$\overline{\text{GW}}$	V <sub>SS</sub>	DQb	DQb
<b>J</b>	V <sub>DDQ</sub>	V <sub>DD</sub>	NC	V <sub>DD</sub>	NC	V <sub>DD</sub>	V <sub>DDQ</sub>
<b>K</b>	DQd	DQd	$\overline{\text{VSS}}$	CLK	$\overline{\text{VSS}}$	DQa	DQa
<b>L</b>	DQd	DQd	$\overline{\text{BWd}}$	NC	$\overline{\text{BWa}}$	DQa	DQa
<b>M</b>	V <sub>DDQ</sub>	DQd	V <sub>SS</sub>	$\overline{\text{BWE}}$	V <sub>SS</sub>	DQa	V <sub>DDQ</sub>
<b>N</b>	DQd	DQd	V <sub>SS</sub>	A1	V <sub>SS</sub>	DQa	DQa
<b>P</b>	DQd	DPd	V <sub>SS</sub>	A0	V <sub>SS</sub>	DPa	DQa
<b>R</b>	NC	A	MODE	V <sub>DD</sub>	NC	A	NC
<b>T</b>	NC	72M	A	A	A	36M	ZZ
<b>U</b>	V <sub>DDQ</sub>	TMS	TDI	TCK	TDO	NC	V <sub>DDQ</sub>

**CY7C1382C (1M x 18)**

	1	2	3	4	5	6	7
<b>A</b>	V <sub>DDQ</sub>	A	A	$\overline{\text{ADSP}}$	A	A	V <sub>DDQ</sub>
<b>B</b>	NC	A	A	$\overline{\text{ADSC}}$	A	A	NC
<b>C</b>	NC	A	A	V <sub>DD</sub>	A	A	NC
<b>D</b>	DQb	NC	V <sub>SS</sub>	NC	V <sub>SS</sub>	DPa	NC
<b>E</b>	NC	DQb	V <sub>SS</sub>	$\overline{\text{CE}}_1$	V <sub>SS</sub>	NC	DQa
<b>F</b>	V <sub>DDQ</sub>	NC	V <sub>SS</sub>	$\overline{\text{OE}}$	V <sub>SS</sub>	DQa	V <sub>DDQ</sub>
<b>G</b>	NC	DQb	$\overline{\text{BWb}}$	$\overline{\text{ADV}}$	V <sub>SS</sub>	NC	DQa
<b>H</b>	DQb	NC	V <sub>SS</sub>	$\overline{\text{GW}}$	V <sub>SS</sub>	DQa	NC
<b>J</b>	V <sub>DDQ</sub>	V <sub>DD</sub>	NC	V <sub>DD</sub>	NC	V <sub>DD</sub>	V <sub>DDQ</sub>
<b>K</b>	NC	DQb	V <sub>SS</sub>	CLK	$\overline{\text{VSS}}$	NC	DQa
<b>L</b>	DQb	NC	V <sub>SS</sub>	NC	$\overline{\text{BWa}}$	DQa	NC
<b>M</b>	V <sub>DDQ</sub>	DQb	V <sub>SS</sub>	$\overline{\text{BWE}}$	V <sub>SS</sub>	NC	V <sub>DDQ</sub>
<b>N</b>	DQb	NC	V <sub>SS</sub>	A1	V <sub>SS</sub>	DQa	NC
<b>P</b>	NC	DPb	V <sub>SS</sub>	A0	V <sub>SS</sub>	NC	DQa
<b>R</b>	NC	A	MODE	V <sub>DD</sub>	NC	A	NC
<b>T</b>	72M	A	A	36M	A	A	ZZ
<b>U</b>	V <sub>DDQ</sub>	TMS	TDI	TCK	TDO	NC	V <sub>DDQ</sub>



Pin Configurations (continued)

165-Ball Bump FBGA

CY7C1380C (512K x 36) - 11 x 15 FBGA

	1	2	3	4	5	6	7	8	9	10	11
<b>A</b>	NC	A	$\overline{CE}_1$	$\overline{BWc}$	$\overline{BWb}$	$\overline{CE}_3$	$\overline{BWE}$	$\overline{ADSC}$	$\overline{ADV}$	A	NC
<b>B</b>	NC	A	$CE_2$	$\overline{BWd}$	$\overline{BWa}$	CLK	$\overline{GW}$	$\overline{OE}$	$\overline{ADSP}$	A	144M
<b>C</b>	DPc	NC	$V_{DDQ}$	$V_{SS}$	$V_{SS}$	$V_{SS}$	$V_{SS}$	$V_{SS}$	$V_{DDQ}$	NC	DPb
<b>D</b>	DQc	DQc	$V_{DDQ}$	$V_{DD}$	$V_{SS}$	$V_{SS}$	$V_{SS}$	$V_{DD}$	$V_{DDQ}$	DQb	DQb
<b>E</b>	DQc	DQc	$V_{DDQ}$	$V_{DD}$	$V_{SS}$	$V_{SS}$	$V_{SS}$	$V_{DD}$	$V_{DDQ}$	DQb	DQb
<b>F</b>	DQc	DQc	$V_{DDQ}$	$V_{DD}$	$V_{SS}$	$V_{SS}$	$V_{SS}$	$V_{DD}$	$V_{DDQ}$	DQb	DQb
<b>G</b>	DQc	DQc	$V_{DDQ}$	$V_{DD}$	$V_{SS}$	$V_{SS}$	$V_{SS}$	$V_{DD}$	$V_{DDQ}$	DQb	DQb
<b>H</b>	NC	$V_{SS}$	NC	$V_{DD}$	$V_{SS}$	$V_{SS}$	$V_{SS}$	$V_{DD}$	NC	NC	ZZ
<b>J</b>	DQd	DQd	$V_{DDQ}$	$V_{DD}$	$V_{SS}$	$V_{SS}$	$V_{SS}$	$V_{DD}$	$V_{DDQ}$	DQa	DQa
<b>K</b>	DQd	DQd	$V_{DDQ}$	$V_{DD}$	$V_{SS}$	$V_{SS}$	$V_{SS}$	$V_{DD}$	$V_{DDQ}$	DQa	DQa
<b>L</b>	DQd	DQd	$V_{DDQ}$	$V_{DD}$	$V_{SS}$	$V_{SS}$	$V_{SS}$	$V_{DD}$	$V_{DDQ}$	DQa	DQa
<b>M</b>	DQd	DQd	$V_{DDQ}$	$V_{DD}$	$V_{SS}$	$V_{SS}$	$V_{SS}$	$V_{DD}$	$V_{DDQ}$	DQa	DQa
<b>N</b>	DPd	NC	$V_{DDQ}$	$V_{SS}$	NC	A	$V_{SS}$	$V_{SS}$	$V_{DDQ}$	NC	DPa
<b>P</b>	NC	72M	A	A	TDI	A1	TDO	A	A	A	A
<b>R</b>	MODE	36M	A	A	TMS	A0	TCK	A	A	A	A

CY7C1382C (1M x 18) - 11 x 15 FBGA

	1	2	3	4	5	6	7	8	9	10	11
<b>A</b>	NC	A	$\overline{CE}_1$	$\overline{BWb}$	NC	$\overline{CE}_3$	$\overline{BWE}$	$\overline{ADSC}$	$\overline{ADV}$	A	A
<b>B</b>	NC	A	$CE_2$	NC	$\overline{BWa}$	CLK	$\overline{GW}$	$\overline{OE}$	$\overline{ADSP}$	A	144M
<b>C</b>	NC	NC	$V_{DDQ}$	$V_{SS}$	$V_{SS}$	$V_{SS}$	$V_{SS}$	$V_{SS}$	$V_{DDQ}$	NC	DPa
<b>D</b>	NC	DQb	$V_{DDQ}$	$V_{DD}$	$V_{SS}$	$V_{SS}$	$V_{SS}$	$V_{DD}$	$V_{DDQ}$	NC	DQa
<b>E</b>	NC	DQb	$V_{DDQ}$	$V_{DD}$	$V_{SS}$	$V_{SS}$	$V_{SS}$	$V_{DD}$	$V_{DDQ}$	NC	DQa
<b>F</b>	NC	DQb	$V_{DDQ}$	$V_{DD}$	$V_{SS}$	$V_{SS}$	$V_{SS}$	$V_{DD}$	$V_{DDQ}$	NC	DQa
<b>G</b>	NC	DQb	$V_{DDQ}$	$V_{DD}$	$V_{SS}$	$V_{SS}$	$V_{SS}$	$V_{DD}$	$V_{DDQ}$	NC	DQa
<b>H</b>	NC	$V_{SS}$	NC	$V_{DD}$	$V_{SS}$	$V_{SS}$	$V_{SS}$	$V_{DD}$	NC	NC	ZZ
<b>J</b>	DQb	NC	$V_{DDQ}$	$V_{DD}$	$V_{SS}$	$V_{SS}$	$V_{SS}$	$V_{DD}$	$V_{DDQ}$	DQa	NC
<b>K</b>	DQb	NC	$V_{DDQ}$	$V_{DD}$	$V_{SS}$	$V_{SS}$	$V_{SS}$	$V_{DD}$	$V_{DDQ}$	DQa	NC
<b>L</b>	DQb	NC	$V_{DDQ}$	$V_{DD}$	$V_{SS}$	$V_{SS}$	$V_{SS}$	$V_{DD}$	$V_{DDQ}$	DQa	NC
<b>M</b>	DQb	NC	$V_{DDQ}$	$V_{DD}$	$V_{SS}$	$V_{SS}$	$V_{SS}$	$V_{DD}$	$V_{DDQ}$	DQa	NC
<b>N</b>	DPb	NC	$V_{DDQ}$	$V_{SS}$	NC	A	$V_{SS}$	$V_{SS}$	$V_{DDQ}$	NC	NC
<b>P</b>	NC	72M	A	A	TDI	A1	TDO	A	A	A	A
<b>R</b>	MODE	36M	A	A	TMS	A0	TCK	A	A	A	A

**Pin Definitions**

Name	I/O	Description
A0 A1 A	Input- Synchronous	<b>Address Inputs used to select one of the address locations.</b> Sampled at the rising edge of the CLK if ADSP or ADSC is active LOW, and $\overline{CE}_1$ , $CE_2$ , and $CE_3$ are sampled active. $A_{[1:0]}$ feed the 2-bit counter.
$\overline{BWA}$ $\overline{BWB}$ $\overline{BWC}$ $\overline{BWD}$	Input- Synchronous	<b>Byte Write Select Inputs, active LOW.</b> Qualified with $\overline{BWE}$ to conduct byte writes to the SRAM. Sampled on the rising edge of CLK.
$\overline{GW}$	Input- Synchronous	<b>Global Write Enable Input, active LOW.</b> When asserted LOW on the rising edge of CLK, a global write is conducted (ALL bytes are written, regardless of the values on $\overline{BW}_{a,b,c,d}$ and $\overline{BWE}$ ).
$\overline{BWE}$	Input- Synchronous	<b>Byte Write Enable Input, active LOW.</b> Sampled on the rising edge of CLK. This signal must be asserted LOW to conduct a byte write.
CLK	Input-Clock	<b>Clock Input.</b> Used to capture all synchronous inputs to the device. Also used to increment the burst counter when ADV is asserted LOW, during a burst operation.
$\overline{CE}_1$	Input- Synchronous	<b>Chip Enable 1 Input, active LOW.</b> Sampled on the rising edge of CLK. Used in conjunction with $CE_2$ and $CE_3$ to select/deselect the device. ADSP is ignored if $\overline{CE}_1$ is HIGH.
$CE_2$	Input- Synchronous	<b>Chip Enable 2 Input, active HIGH.</b> Sampled on the rising edge of CLK. Used in conjunction with $\overline{CE}_1$ and $\overline{CE}_3$ to select/deselect the device. (TQFP Only)
$\overline{CE}_3$	Input- Synchronous	<b>Chip Enable 3 Input, active LOW.</b> Sampled on the rising edge of CLK. Used in conjunction with $\overline{CE}_1$ and $CE_2$ to select/deselect the device. (TQFP Only)
$\overline{OE}$	Input- Asynchronous	<b>Output Enable, asynchronous input, active LOW.</b> Controls the direction of the I/O pins. When LOW, the I/O pins behave as outputs. When deasserted HIGH, I/O pins are three-stated, and act as input data pins. $\overline{OE}$ is masked during the first clock of a read cycle when emerging from a deselected state.
ADV	Input- Synchronous	<b>Advance Input signal, sampled on the rising edge of CLK.</b> When asserted, it automatically increments the address in a burst cycle.
$\overline{ADSP}$	Input- Synchronous	<b>Address Strobe from Processor, sampled on the rising edge of CLK.</b> When asserted LOW, A is captured in the address registers. $A_{[1:0]}$ are also loaded into the burst counter. When $\overline{ADSP}$ and $\overline{ADSC}$ are both asserted, only $\overline{ADSP}$ is recognized. $\overline{ADSP}$ is ignored when $\overline{CE}_1$ is deasserted HIGH.
$\overline{ADSC}$	Input- Synchronous	<b>Address Strobe from Controller, sampled on the rising edge of CLK.</b> When asserted LOW, $A_{[x:0]}$ is captured in the address registers. $A_{[1:0]}$ are also loaded into the burst counter. When $\overline{ADSP}$ and $\overline{ADSC}$ are both asserted, only $\overline{ADSP}$ is recognized.
MODE	Input Pin	<b>Selects Burst Order.</b> When tied to GND selects linear burst sequence. When tied to $V_{DDQ}$ or left floating selects interleaved burst sequence. This is a strap pin and should remain static during device operation.
ZZ	Input- Asynchronous	<b>ZZ "sleep" Input.</b> This active HIGH input places the device in a non-time critical "sleep" condition with data integrity preserved.
DQa, DPa DQb, DPb DQc, DPc DQd, DPd	I/O- Synchronous	<b>Bidirectional Data I/O lines.</b> As inputs, they feed into an on-chip data register that is triggered by the rising edge of CLK. As outputs, they deliver the data contained in the memory location specified by $A_x$ during the previous clock rise of the read cycle. The direction of the pins is controlled by $\overline{OE}$ . When $\overline{OE}$ is asserted LOW, the pins behave as outputs. When HIGH, $DQ_x$ and $DP_x$ are placed in a three-state condition. $DQ$ a,b,c and d are 8 bits wide. $DP$ a,b,c and d are 1 bit wide.
TDO	JTAG serial output Synchronous	<b>Serial data-out to the JTAG circuit.</b> Delivers data on the negative edge of TCK. (BGA and FBGA Only)
TDI	JTAG serial input Synchronous	<b>Serial data-In to the JTAG circuit.</b> Sampled on the rising edge of TCK. (BGA and FBGA Only)
TMS	Test Mode Select Synchronous	<b>This pin controls the Test Access Port state machine.</b> Sampled on the rising edge of TCK. (BGA and FBGA Only)

**Pin Definitions**

Name	I/O	Description
TCK	JTAG serial clock	<b>Serial clock to the JTAG circuit.</b> (BGA and FBGA Only)
V <sub>DD</sub>	Power Supply	<b>Power supply inputs to the core of the device.</b> Should be connected to 3.3V -5% +10% power supply.
V <sub>SS</sub>	Ground	<b>Ground for the core of the device.</b> Should be connected to ground of the system.
V <sub>DDQ</sub>	I/O Power Supply	<b>Power supply for the I/O circuitry.</b> Should be connected to a 2.5 -5% to 3.3V +10% power supply.
V <sub>SSQ</sub>	I/O Ground	<b>Ground for the I/O circuitry.</b> Should be connected to ground of the system.
36M 72M 144M	-	<b>No connects.</b> Reserved for address expansion. Pins are not internally connected.
NC	-	<b>No connects.</b> Pins are not internally connected.



## Introduction

### Functional Overview

All synchronous inputs pass through input registers controlled by the rising edge of the clock. All data outputs pass through output registers controlled by the rising edge of the clock. Maximum access delay from the clock rise ( $t_{CO}$ ) is 2.6 ns (250-MHz device).

The CY7C1380C/CY7C1382C supports secondary cache in systems utilizing either a linear or interleaved burst sequence. The interleaved burst order supports Pentium® and i486 processors. The linear burst sequence is suited for processors that utilize a linear burst sequence. The burst order is user selectable, and is determined by sampling the MODE input. Accesses can be initiated with either the Processor Address Strobe (ADSP) or the Controller Address Strobe (ADSC). Address advancement through the burst sequence is controlled by the ADV input. A two-bit on-chip wraparound burst counter captures the first address in a burst sequence and automatically increments the address for the rest of the burst access.

Byte write operations are qualified with the Byte Write Enable (BWE) and Byte Write Select ( $BW_{a,b,c,d}$  for CY7C1380C and  $BW_{a,b}$  for CY7C1382C) inputs. A Global Write Enable (GW) overrides all byte write inputs and writes data to all four bytes. All writes are simplified with on-chip synchronous self-timed write circuitry.

Synchronous Chip Selects ( $\overline{CE}_1$ ,  $CE_2$ ,  $\overline{CE}_3$  for TQFP/ $\overline{CE}_1$  for BGA) and an asynchronous Output Enable ( $\overline{OE}$ ) provide for easy bank selection and output three-state control. ADSP is ignored if  $\overline{CE}_1$  is HIGH.

#### Single Read Accesses

This access is initiated when the following conditions are satisfied at clock rise: (1) ADSP or ADSC is asserted LOW, (2) chip selects are all asserted active, and (3) the write signals (GW, BWE) are all deasserted HIGH. ADSP is ignored if  $\overline{CE}_1$  is HIGH. The address presented to the address inputs is stored into the address advancement logic and the Address Register while being presented to the memory core. The corresponding data is allowed to propagate to the input of the Output Registers. At the rising edge of the next clock the data is allowed to propagate through the output register and onto the data bus within 2.6 ns (250-MHz device) if  $\overline{OE}$  is active LOW. The only exception occurs when the SRAM is emerging from a deselected state to a selected state, its outputs are always three-stated during the first cycle of the access. After the first cycle of the access, the outputs are controlled by the  $\overline{OE}$  signal. Consecutive single read cycles are supported. Once the SRAM is deselected at clock rise by the chip select and either ADSP or ADSC signals, its output will three-state immediately.

#### Single Write Accesses Initiated by ADSP

This access is initiated when both of the following conditions are satisfied at clock rise: (1) ADSP is asserted LOW, and (2) chip select is asserted active. The address presented is loaded into the address register and the address advancement logic while being delivered to the RAM core. The write signals

( $\overline{GW}$ ,  $\overline{BWE}$ , and  $\overline{BWx}$ ) and  $\overline{ADV}$  inputs are ignored during this first cycle.

ADSP triggered write accesses require two clock cycles to complete. If GW is asserted LOW on the second clock rise, the data presented to the DQx inputs is written into the corresponding address location in the RAM core. If  $\overline{GW}$  is HIGH, then the write operation is controlled by BWE and  $\overline{BWx}$  signals. The CY7C1380C/CY7C1382C provides byte write capability that is described in the Write Cycle Description table. Asserting the Byte Write Enable input (BWE) with the selected Byte Write ( $\overline{BW}_{a,b,c,d}$  for CY7C1380C and  $\overline{BW}_{a,b}$  for CY7C1382C) input will selectively write to only the desired bytes. Bytes not selected during a byte write operation will remain unaltered. A synchronous self-timed write mechanism has been provided to simplify the write operations.

Because the CY7C1380C/CY7C1382C is a common I/O device, the Output Enable ( $\overline{OE}$ ) must be deasserted HIGH before presenting data to the DQ inputs. Doing so will three-state the output drivers. As a safety precaution, DQ are automatically three-stated whenever a write cycle is detected, regardless of the state of  $\overline{OE}$ .

#### Single Write Accesses Initiated by ADSC

ADSC write accesses are initiated when the following conditions are satisfied: (1) ADSC is asserted LOW, (2) ADSP is deasserted HIGH, (3) chip select is asserted active, and (4) the appropriate combination of the write inputs (GW, BWE, and  $\overline{BWx}$ ) are asserted active to conduct a write to the desired byte(s). ADSC triggered write accesses require a single clock cycle to complete. The address presented to  $A_{[17:0]}$  is loaded into the address register and the address advancement logic while being delivered to the RAM core. The  $\overline{ADV}$  input is ignored during this cycle. If a global write is conducted, the data presented to the  $DQ_{[x:0]}$  is written into the corresponding address location in the RAM core. If a byte write is conducted, only the selected bytes are written. Bytes not selected during a byte write operation will remain unaltered. A synchronous self-timed write mechanism has been provided to simplify the write operations.

Because the CY7C1380C/CY7C1382C is a common I/O device, the Output Enable ( $\overline{OE}$ ) must be deasserted HIGH before presenting data to the  $DQ_{[x:0]}$  inputs. Doing so will three-state the output drivers. As a safety precaution,  $DQ_{[x:0]}$  are automatically three-stated whenever a write cycle is detected, regardless of the state of  $\overline{OE}$ .

## Burst Sequences

The CY7C1380C/CY7C1382C provides a two-bit wraparound counter, fed by  $A_{[1:0]}$ , that implements either an interleaved or linear burst sequence. The interleaved burst sequence is designed specifically to support Intel® Pentium applications. The linear burst sequence is designed to support processors that follow a linear burst sequence. The burst sequence is user selectable through the MODE input.

Asserting  $\overline{ADV}$  LOW at clock rise will automatically increment the burst counter to the next address in the burst sequence. Both read and write burst operations are supported.



**Interleaved Burst Sequence**

First Address	Second Address	Third Address	Fourth Address
$A_{[1:0]}$	$A_{[1:0]}$	$A_{[1:0]}$	$A_{[1:0]}$
00	01	10	11
01	00	11	10
10	11	00	01
11	10	01	00

**Linear Burst Sequence**

First Address	Second Address	Third Address	Fourth Address
$A_{[1:0]}$	$A_{[1:0]}$	$A_{[1:0]}$	$A_{[1:0]}$
00	01	10	11
01	10	11	00
10	11	00	01
11	00	01	10

**Sleep Mode**

The ZZ input pin is an asynchronous input. Asserting ZZ places the SRAM in a power conservation “sleep” mode. Two clock cycles are required to enter into or exit from this “sleep” mode. While in this mode, data integrity is guaranteed. Accesses pending when entering the “sleep” mode are not considered valid nor is the completion of the operation guaranteed. The device must be deselected prior to entering the “sleep” mode. CEs, ADSP, and ADSC must remain inactive for the duration of  $t_{ZZREC}$  after the ZZ input returns LOW

**ZZ Mode Electrical Characteristics**

Parameter	Description	Test Conditions	Min.	Max.	Unit
$I_{DDZZ}$	Sleep mode stand-by current	$ZZ \geq V_{DD} - 0.2V$		60	mA
$t_{ZZS}$	Device operation to ZZ	$ZZ \geq V_{DD} - 0.2V$		$2t_{CYC}$	ns
$t_{ZZREC}$	ZZ recovery time	$ZZ \leq 0.2V$	$2t_{CYC}$		ns



Cycle Descriptions<sup>[1, 2, 3, 4]</sup>

Next Cycle	Add. Used	ZZ	$\overline{CE}_3$	$CE_2$	$\overline{CE}_1$	$\overline{ADSP}$	$\overline{ADSC}$	$\overline{ADV}$	$\overline{OE}$	DQ	Write
Unselected	None	0	X	X	1	X	0	X	X	Hi-Z	X
Unselected	None	0	1	X	0	0	X	X	X	Hi-Z	X
Unselected	None	0	X	0	0	0	X	X	X	Hi-Z	X
Unselected	None	0	1	X	0	1	0	X	X	Hi-Z	X
Unselected	None	0	X	0	0	1	0	X	X	Hi-Z	X
Begin Read	External	0	0	1	0	0	X	X	X	Hi-Z	X
Begin Read	External	0	0	1	0	1	0	X	X	Hi-Z	Read
Continue Read	Next	0	X	X	X	1	1	0	1	Hi-Z	Read
Continue Read	Next	0	X	X	X	1	1	0	0	DQ	Read
Continue Read	Next	0	X	X	1	X	1	0	1	Hi-Z	Read
Continue Read	Next	0	X	X	1	X	1	0	0	DQ	Read
Suspend Read	Current	0	X	X	X	1	1	1	1	Hi-Z	Read
Suspend Read	Current	0	X	X	X	1	1	1	0	DQ	Read
Suspend Read	Current	0	X	X	1	X	1	1	1	Hi-Z	Read
Suspend Read	Current	0	X	X	1	X	1	1	0	DQ	Read
Begin Write	Current	0	X	X	X	1	1	1	X	Hi-Z	Write
Begin Write	Current	0	X	X	1	X	1	1	X	Hi-Z	Write
Begin Write	External	0	0	1	0	1	0	X	X	Hi-Z	Write
Continue Write	Next	0	X	X	X	1	1	0	X	Hi-Z	Write
Continue Write	Next	0	X	X	1	X	1	0	X	Hi-Z	Write
Suspend Write	Current	0	X	X	X	1	1	1	X	Hi-Z	Write
Suspend Write	Current	0	X	X	1	X	1	1	X	Hi-Z	Write
ZZ "sleep"	None	1	X	X	X	X	X	X	X	Hi-Z	X

Notes:

1. X = "Don't Care." 1 = HIGH, 0 = LOW.
2. Write is defined by BWE, BWx, and GW. See Write Cycle Descriptions table.
3. The DQ pins are controlled by the current cycle and the OE signal. OE is asynchronous and is not sampled with the clock.
4.  $CE_1$ ,  $CE_2$ , and  $CE_3$  are available only in the TQFP package. The BGA package has a single chip select,  $CE_1$ .



Write Cycle Descriptions<sup>[1, 5, 6]</sup>

Function (1380C)	$\overline{GW}$	$\overline{BWE}$	$\overline{BWd}$	$\overline{BWc}$	$\overline{BWb}$	$\overline{BWa}$
Read	1	1	X	X	X	X
Read	1	0	1	1	1	1
Write Byte 0 – DQa	1	0	1	1	1	0
Write Byte 1 – DQb	1	0	1	1	0	1
Write Bytes 1, 0	1	0	1	1	0	0
Write Byte 2 – DQc	1	0	1	0	1	1
Write Bytes 2, 0	1	0	1	0	1	0
Write Bytes 2, 1	1	0	1	0	0	1
Write Bytes 2, 1, 0	1	0	1	0	0	0
Write Byte 3 – DQd	1	0	0	1	1	1
Write Bytes 3, 0	1	0	0	1	1	0
Write Bytes 3, 1	1	0	0	1	0	1
Write Bytes 3, 1, 0	1	0	0	1	0	0
Write Bytes 3, 2	1	0	0	0	1	1
Write Bytes 3, 2, 0	1	0	0	0	1	0
Write Bytes 3, 2, 1	1	0	0	0	0	1
Write All Bytes	1	0	0	0	0	0
Write All Bytes	0	X	X	X	X	X

Function (1382C)	$\overline{GW}$	$\overline{BWE}$	$\overline{BWb}$	$\overline{BWa}$
Read	1	1	X	X
Read	1	0	1	1
Write Byte 0 – DQ <sub>[7:0]</sub> and DP <sub>0</sub>	1	0	1	0
Write Byte 1 – DQ <sub>[15:8]</sub> and DP <sub>1</sub>	1	0	0	1
Write All Bytes	1	0	0	0
Write All Bytes	0	X	X	X

Notes:

- The SRAM always initiates a read cycle when  $\overline{ADSP}$  asserted, regardless of the state of  $\overline{GW}$ ,  $\overline{BWE}$ , or  $\overline{BW}_x$ . Writes may occur only on subsequent clocks after the  $\overline{ADSP}$  or with the assertion of  $\overline{ADSC}$ . As a result, OE must be driven HIGH prior to the start of the write cycle to allow the outputs to three-state. OE is a "don't care" for the remainder of the write cycle.
- $\overline{OE}$  is asynchronous and is not sampled with the clock rise. It is masked internally during write cycles. During a read cycle DQ = High-Z when  $\overline{OE}$  is inactive or when the device is deselected, and DQ = data when OE is active.

## IEEE 1149.1 Serial Boundary Scan (JTAG)

The CY7C1380C/CY7C1382C incorporates a serial boundary scan Test Access Port (TAP) in the FBGA package only. The TQFP package does not offer this functionality. This port operates in accordance with IEEE Standard 1149.1-1900, but does not have the set of functions required for full 1149.1 compliance. These functions from the IEEE specification are excluded because their inclusion places an added delay in the critical speed path of the SRAM. Note that the TAP controller functions in a manner that does not conflict with the operation of other devices using 1149.1 fully compliant TAPs. The TAP operates using JEDEC standard 3.3V I/O logic levels.

### Disabling the JTAG Feature

It is possible to operate the SRAM without using the JTAG feature. To disable the TAP controller, TCK must be tied LOW ( $V_{SS}$ ) to prevent clocking of the device. TDI and TMS are internally pulled up and may be unconnected. They may alternately be connected to  $V_{DD}$  through a pull-up resistor. TDO should be left unconnected. Upon power-up, the device will come up in a reset state which will not interfere with the operation of the device.

### Test Access Port (TAP)—Test Clock

The test clock is used only with the TAP controller. All inputs are captured on the rising edge of TCK. All outputs are driven from the falling edge of TCK.

### Test Mode Select

The TMS input is used to give commands to the TAP controller and is sampled on the rising edge of TCK. It is allowable to leave this pin unconnected if the TAP is not used. The pin is pulled up internally, resulting in a logic HIGH level.

### Test Data-In (TDI)

The TDI pin is used to serially input information into the registers and can be connected to the input of any of the registers. The register between TDI and TDO is chosen by the instruction that is loaded into the TAP instruction register. For information on loading the instruction register, see the TAP Controller State Diagram. TDI is internally pulled up and can be unconnected if the TAP is unused in an application. TDI is connected to the Most Significant Bit (MSB) on any register.

### Test Data Out (TDO)

The TDO output pin is used to serially clock data-out from the registers. The output is active depending upon the current state of the TAP state machine (see TAP Controller State Diagram). The output changes on the falling edge of TCK. TDO is connected to the Least Significant Bit (LSB) of any register.

### Performing a TAP Reset

A Reset is performed by forcing TMS HIGH ( $V_{DD}$ ) for five rising edges of TCK. This RESET does not affect the operation of the SRAM and may be performed while the SRAM is operating. At power-up, the TAP is reset internally to ensure that TDO comes up in a high-Z state.

### TAP Registers

Registers are connected between the TDI and TDO pins and allow data to be scanned into and out of the SRAM test circuit-

ry. Only one register can be selected at a time through the instruction registers. Data is serially loaded into the TDI pin on the rising edge of TCK. Data is output on the TDO pin on the falling edge of TCK.

#### *Instruction Register*

Three-bit instructions can be serially loaded into the instruction register. This register is loaded when it is placed between the TDI and TDO pins as shown in the TAP Controller Block Diagram. Upon power-up, the instruction register is loaded with the IDCODE instruction. It is also loaded with the IDCODE instruction if the controller is placed in a reset state as described in the previous section.

When the TAP controller is in the CaptureIR state, the two least significant bits are loaded with a binary "01" pattern to allow for fault isolation of the board level serial test path.

#### *Bypass Register*

To save time when serially shifting data through registers, it is sometimes advantageous to skip certain states. The bypass register is a single-bit register that can be placed between TDI and TDO pins. This allows data to be shifted through the SRAM with minimal delay. The bypass register is set LOW ( $V_{SS}$ ) when the BYPASS instruction is executed.

#### *Boundary Scan Register*

The boundary scan register is connected to all the input and output pins on the SRAM. Several no connect (NC) pins are also included in the scan register to reserve pins for higher density devices. The x36 configuration has a 70-bit-long register, and the x18 configuration has a 51-bit-long register.

The boundary scan register is loaded with the contents of the RAM Input and Output ring when the TAP controller is in the Capture-DR state and is then placed between the TDI and TDO pins when the controller is moved to the Shift-DR state. The EXTEST, SAMPLE/PRELOAD and SAMPLE Z instructions can be used to capture the contents of the Input and Output ring.

The Boundary Scan Order tables show the order in which the bits are connected. Each bit corresponds to one of the bumps on the SRAM package. The MSB of the register is connected to TDI, and the LSB is connected to TDO.

#### *Identification (ID) Register*

The ID register is loaded with a vendor-specific, 32-bit code during the Capture-DR state when the IDCODE command is loaded in the instruction register. The IDCODE is hardwired into the SRAM and can be shifted out when the TAP controller is in the Shift-DR state. The ID register has a vendor code and other information described in the Identification Register Definitions table.

### TAP Instruction Set

Eight different instructions are possible with the three-bit instruction register. All combinations are listed in the Instruction Code table. Three of these instructions are listed as RESERVED and should not be used. The other five instructions are described in detail below.

The TAP controller used in this SRAM is not fully compliant to the 1149.1 convention because some of the mandatory 1149.1 instructions are not fully implemented. The TAP controller cannot be used to load address, data or control signals into the

SRAM and cannot preload the Input or Output buffers. The SRAM does not implement the 1149.1 commands EXTEST or INTEST or the PRELOAD portion of SAMPLE/PRELOAD; rather it performs a capture of the Input and Output ring when these instructions are executed.

Instructions are loaded into the TAP controller during the Shift-IR state when the instruction register is placed between TDI and TDO. During this state, instructions are shifted through the instruction register through the TDI and TDO pins. To execute the instruction once it is shifted in, the TAP controller needs to be moved into the Update-IR state.

#### EXTEST

EXTEST is a mandatory 1149.1 instruction which is to be executed whenever the instruction register is loaded with all 0s. EXTEST is not implemented in the TAP controller, and therefore this device is not compliant to the 1149.1 standard.

The TAP controller does not recognize an all-0 instruction. When an EXTEST instruction is loaded into the instruction register, the SRAM responds as if a SAMPLE/PRELOAD instruction has been loaded. There is one difference between the two instructions. Unlike the SAMPLE/PRELOAD instruction, EXTEST places the SRAM outputs in a High-Z state.

#### IDCODE

The IDCODE instruction causes a vendor-specific, 32-bit code to be loaded into the instruction register. It also places the instruction register between the TDI and TDO pins and allows the IDCODE to be shifted out of the device when the TAP controller enters the Shift-DR state. The IDCODE instruction is loaded into the instruction register upon power-up or whenever the TAP controller is given a test logic reset state.

#### SAMPLE Z

The SAMPLE Z instruction causes the boundary scan register to be connected between the TDI and TDO pins when the TAP controller is in a Shift-DR state. It also places all SRAM outputs into a High-Z state.

#### SAMPLE/PRELOAD

SAMPLE/PRELOAD is a 1149.1 mandatory instruction. The PRELOAD portion of this instruction is not implemented, so the TAP controller is not fully 1149.1 compliant.

When the SAMPLE/PRELOAD instructions are loaded into the instruction register and the TAP controller is in the Capture-DR state, a snapshot of data on the input and output pins is captured in the boundary scan register.

The user must be aware that the TAP controller clock can only operate at a frequency up to 10 MHz, while the SRAM clock operates more than an order of magnitude faster. Because there is a large difference in the clock frequencies, it is possible that during the Capture-DR state, an input or output will undergo a transition. The TAP may then try to capture a signal while in transition (metastable state). This will not harm the device, but there is no guarantee as to the value that will be captured. Repeatable results may not be possible.

To guarantee that the boundary scan register will capture the correct value of a signal, the SRAM signal must be stabilized long enough to meet the TAP controller's capture set-up plus hold times ( $t_{CS}$  and  $t_{CH}$ ). The SRAM clock input might not be captured correctly if there is no way in a design to stop (or slow) the clock during a SAMPLE/PRELOAD instruction. If this is an issue, it is still possible to capture all other signals and simply ignore the value of the CK and  $\overline{CK}$  captured in the boundary scan register.

Once the data is captured, it is possible to shift out the data by putting the TAP into the Shift-DR state. This places the boundary scan register between the TDI and TDO pins.

Note that since the PRELOAD part of the command is not implemented, putting the TAP into the Update to the Update-DR state while performing a SAMPLE/PRELOAD instruction will have the same effect as the Pause-DR command.

#### Bypass

When the BYPASS instruction is loaded in the instruction register and the TAP is placed in a Shift-DR state, the bypass register is placed between the TDI and TDO pins. The advantage of the BYPASS instruction is that it shortens the boundary scan path when multiple devices are connected together on a board.

#### Reserved

These instructions are not implemented but are reserved for future use. Do not use these instructions.

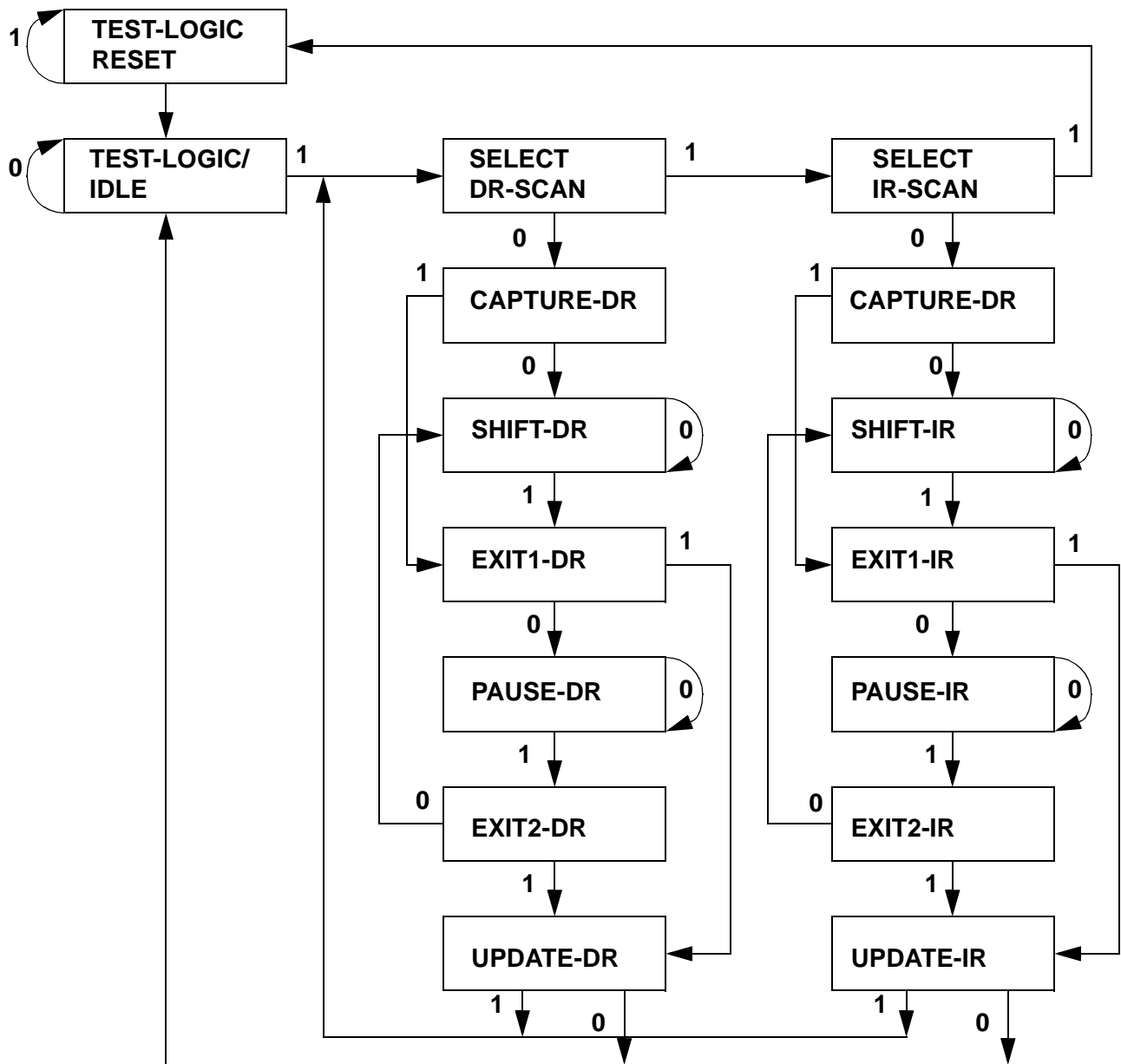
**TAP Controller State Diagram**

Note: The 0/1 next to each state represents the value at TMS at the rising edge of TCK.

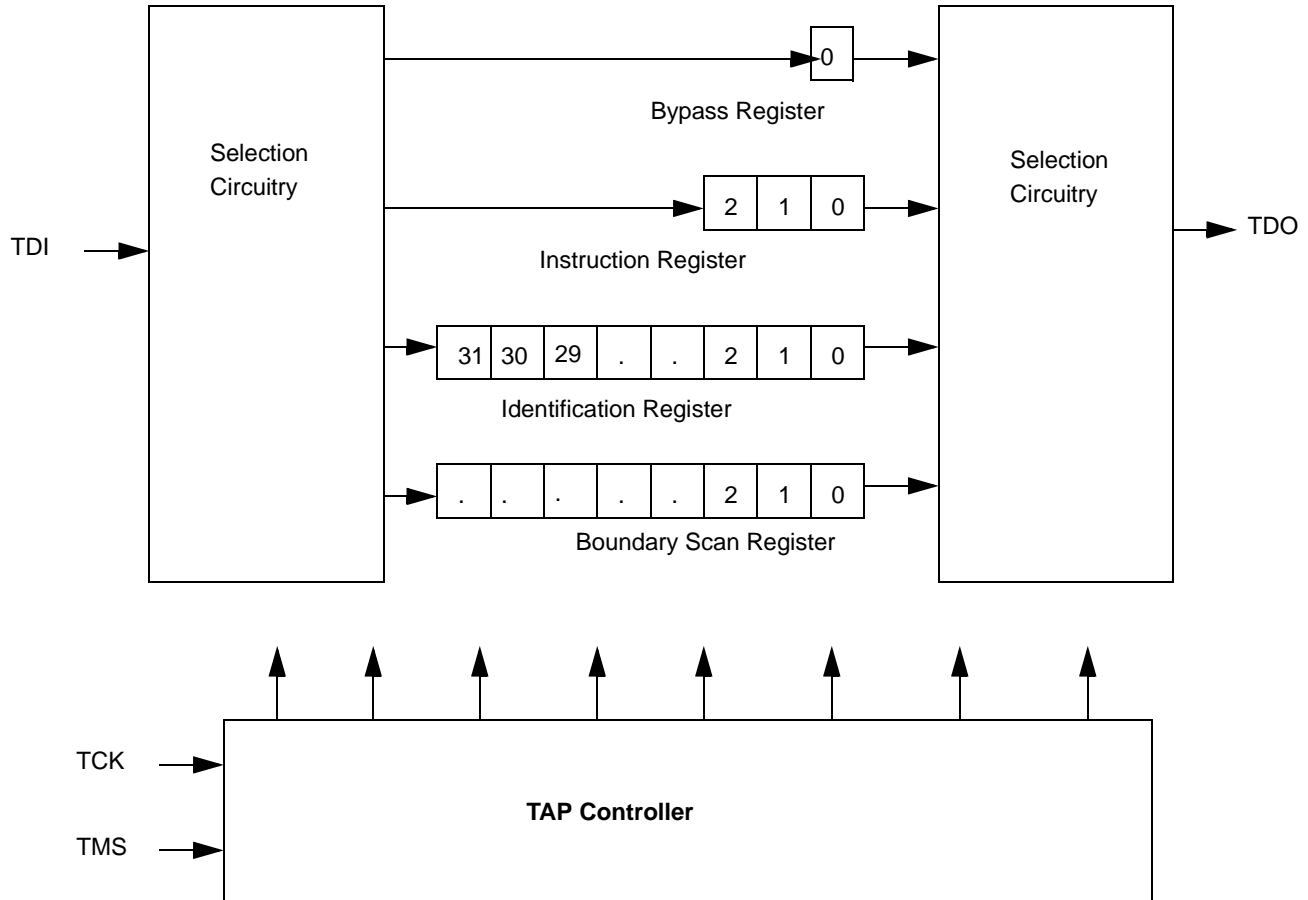
**TAP Controller Block Diagram**

**TAP Electrical Characteristics** Over the Operating Range<sup>[7, 8]</sup> ( $3.135 \leq V_{DD} \leq 3.63$ )

Parameter	Description	Test Conditions		Min.	Max.	Unit
V <sub>OH1</sub>	Output HIGH Voltage	I <sub>OH</sub> = -4.0 mA	V <sub>DDQ</sub> = 3.3V	2.4		V
		I <sub>OH</sub> = -1.0 mA	V <sub>DDQ</sub> = 2.5V	1.7		V
V <sub>OH2</sub>	Output HIGH Voltage	I <sub>OH</sub> = -100 μA	V <sub>DDQ</sub> = 3.3V	2.9		V
			V <sub>DDQ</sub> = 2.5V	2.1		V
V <sub>OL1</sub>	Output LOW Voltage	I <sub>OL</sub> = 8.0 mA	V <sub>DDQ</sub> = 3.3V		0.4	V
		I <sub>OL</sub> = 1.0 mA	V <sub>DDQ</sub> = 2.5V		0.4	V
V <sub>OL2</sub>	Output LOW Voltage	I <sub>OL</sub> = 100 μA	V <sub>DDQ</sub> = 3.3V		0.2	V
			V <sub>DDQ</sub> = 2.5V		0.2	V
V <sub>IH</sub>	Input HIGH Voltage		V <sub>DDQ</sub> = 3.3V	2.0	V <sub>DD</sub> + 0.3	V
			V <sub>DDQ</sub> = 2.5V	1.7	V <sub>DD</sub> + 0.3	V
V <sub>IL</sub>	Input LOW Voltage		V <sub>DDQ</sub> = 3.3V	-0.5	0.7	V
			V <sub>DDQ</sub> = 2.5V	-0.3	0.7	V
I <sub>X</sub>	Input Load Current	GND ≤ V <sub>I</sub> ≤ V <sub>DDQ</sub>		-5	5	μA

**Notes:**

7. All Voltage referenced to Ground.
8. Overshoot: V<sub>IH</sub>(AC) ≤ V<sub>DD</sub>+1.5V for t ≤ t<sub>TCYC</sub>/2, Undershoot: V<sub>IL</sub>(AC) ≥ -0.5V for t ≤ t<sub>TCYC</sub>/2.



**TAP AC Switching Characteristics** Over the Operating Range<sup>[9, 10]</sup>

Parameters	Description	Min.	Max	Unit
$t_{TCYC}$	TCK Clock Cycle Time	100		ns
$t_{TF}$	TCK Clock Frequency		10	MHz
$t_{TH}$	TCK Clock HIGH	40		ns
$t_{TL}$	TCK Clock LOW	40		ns
<b>Set-up Times</b>				
$t_{TMSS}$	TMS Set-up to TCK Clock Rise	10		ns
$t_{TDIS}$	TDI Set-up to TCK Clock Rise	10		ns
$t_{CS}$	Capture Set-up to TCK Rise	10		ns
<b>Hold Times</b>				
$t_{TMSH}$	TMS Hold after TCK Clock Rise	10		ns
$t_{TDIH}$	TDI Hold after Clock Rise	10		ns
$t_{CH}$	Capture Hold after Clock Rise	10		ns
<b>Output Times</b>				
$t_{TDOV}$	TCK Clock LOW to TDO Valid		20	ns
$t_{TDOX}$	TCK Clock LOW to TDO Invalid	0		ns

**Notes:**

9.  $t_{CS}$  and  $t_{CH}$  refer to the set-up and hold time requirements of latching data from the boundary scan register.  
 10. Test conditions are specified using the load in TAP AC Test Conditions.  $t_R/t_F = 1 \text{ V/ ns}$ .

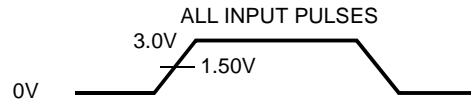
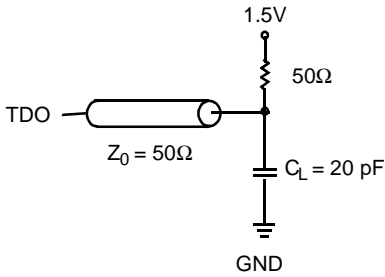
**TAP Timing and Test Conditions**

(a)

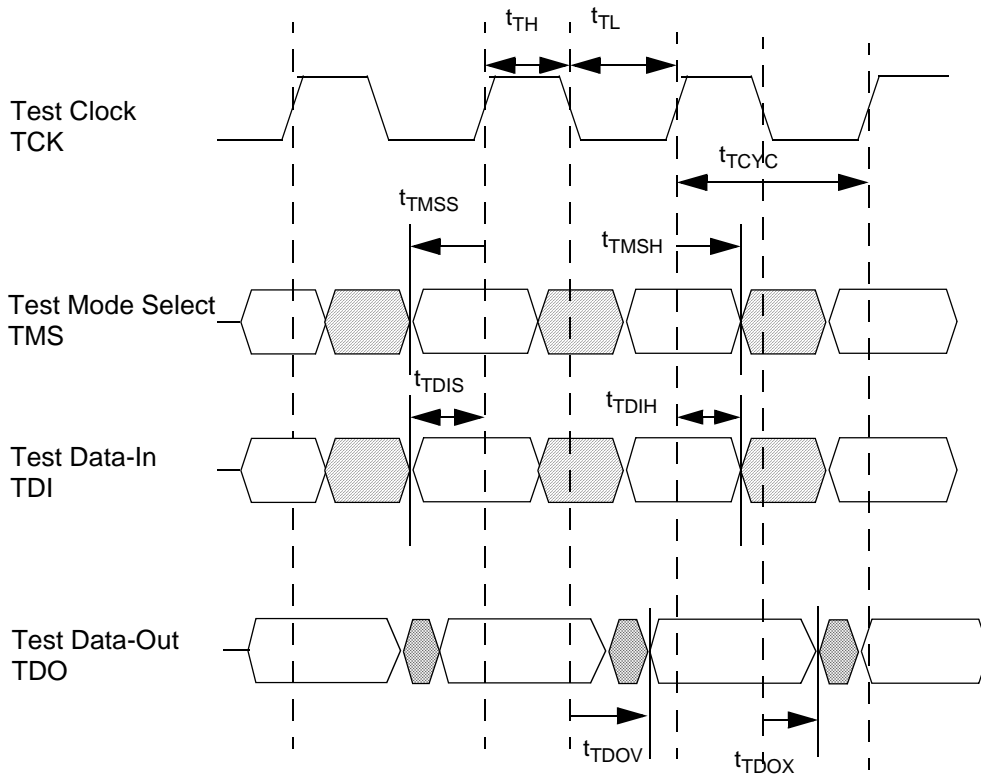

**Identification Register Definitions**

Instruction Field	512K x 36	1M x 18	Description
Revision Number (31:28)	0100	0100	Reserved for version number.
Cypress Device ID (27:24)	1010	1010	Reserved for internal use.
Device Type (23:18)	000000	000000	Defines memory type and architecture
Device Width and Density (17:12)	100101	010101	Defines width and density.
Cypress JEDEC ID (11:0)	000001101001	000001101001	Allows unique identification of SRAM vendor.

**Scan Register Sizes**

Register Name	Bit Size (x18)	Bit Size (x36)
Instruction	3	3
Bypass	1	1
ID	32	32
Boundary Scan	51	70

**Identification Codes**

Instruction	Code	Description
EXTEST	000	Captures the Input/Output ring contents. Places the boundary scan register between the TDI and TDO. Forces all SRAM outputs to High-Z state. This instruction is not 1149.1 compliant.
IDCODE	001	Loads the ID register with the vendor ID code and places the register between TDI and TDO. This operation does not affect SRAM operation.
SAMPLE Z	010	Captures the Input/Output contents. Places the boundary scan register between TDI and TDO. Forces all SRAM output drivers to a High-Z state.
RESERVED	011	Do Not Use: This instruction is reserved for future use.
SAMPLE/PRELOAD	100	Captures the Input/Output ring contents. Places the boundary scan register between TDI and TDO. Does not affect the SRAM operation. This instruction does not implement 1149.1 preload function and is therefore not 1149.1 compliant.
RESERVED	101	Do Not Use: This instruction is reserved for future use.
RESERVED	110	Do Not Use: This instruction is reserved for future use.
BYPASS	111	Places the bypass register between TDI and TDO. This operation does not affect SRAM operation.



**Boundary Scan Order (512K X 36)-119 BGA**

Bit #	Signal Name	Bump ID	Bit #	Signal Name	Bump ID
1	TBD	TBD	36	TBD	TBD
2	TBD	TBD	37	TBD	TBD
3	TBD	TBD	38	TBD	TBD
4	TBD	TBD	39	TBD	TBD
5	TBD	TBD	40	TBD	TBD
6	TBD	TBD	41	TBD	TBD
7	TBD	TBD	42	TBD	TBD
8	TBD	TBD	43	TBD	TBD
9	TBD	TBD	44	TBD	TBD
10	TBD	TBD	45	TBD	TBD
11	TBD	TBD	46	TBD	TBD
12	TBD	TBD	47	TBD	TBD
13	TBD	TBD	48	TBD	TBD
14	TBD	TBD	49	TBD	TBD
15	TBD	TBD	50	TBD	TBD
16	TBD	TBD	51	TBD	TBD
17	TBD	TBD	52	TBD	TBD
18	TBD	TBD	53	TBD	TBD
19	TBD	TBD	54	TBD	TBD
20	TBD	TBD	55	TBD	TBD
21	TBD	TBD	56	TBD	TBD
22	TBD	TBD	57	TBD	TBD
23	TBD	TBD	58	TBD	TBD
24	TBD	TBD	59	TBD	TBD
25	TBD	TBD	60	TBD	TBD
26	TBD	TBD	61	TBD	TBD
27	TBD	TBD	62	TBD	TBD
28	TBD	TBD	63	TBD	TBD
29	TBD	TBD	64	TBD	TBD
30	TBD	TBD	65	TBD	TBD
31	TBD	TBD	66	TBD	TBD
32	TBD	TBD	67	TBD	TBD
33	TBD	TBD	68	TBD	TBD
34	TBD	TBD	69	TBD	TBD
35	TBD	TBD	70	TBD	TBD

**Boundary Scan Order (1M X 18)-119 BGA**

Bit #	Signal Name	Bump ID	Bit #	Signal Name	Bump ID
1	TBD	TBD	36	TBD	TBD
2	TBD	TBD	37	TBD	TBD
3	TBD	TBD	38	TBD	TBD
4	TBD	TBD	39	TBD	TBD
5	TBD	TBD	40	TBD	TBD
6	TBD	TBD	41	TBD	TBD
7	TBD	TBD	42	TBD	TBD
8	TBD	TBD	43	TBD	TBD
9	TBD	TBD	44	TBD	TBD
10	TBD	TBD	45	TBD	TBD
11	TBD	TBD	46	TBD	TBD
12	TBD	TBD	47	TBD	TBD
13	TBD	TBD	48	TBD	TBD
14	TBD	TBD	49	TBD	TBD
15	TBD	TBD	50	TBD	TBD
16	TBD	TBD	51	TBD	TBD
17	TBD	TBD	52	TBD	TBD
18	TBD	TBD	53	TBD	TBD
19	TBD	TBD	54	TBD	TBD
20	TBD	TBD	55	TBD	TBD
21	TBD	TBD	56	TBD	TBD
22	TBD	TBD	57	TBD	TBD
23	TBD	TBD	58	TBD	TBD
24	TBD	TBD	59	TBD	TBD
25	TBD	TBD	60	TBD	TBD
26	TBD	TBD	61	TBD	TBD
27	TBD	TBD	62	TBD	TBD
28	TBD	TBD	63	TBD	TBD
29	TBD	TBD	64	TBD	TBD
30	TBD	TBD	65	TBD	TBD
31	TBD	TBD	66	TBD	TBD
32	TBD	TBD	67	TBD	TBD
33	TBD	TBD	68	TBD	TBD
34	TBD	TBD	69	TBD	TBD
35	TBD	TBD	70	TBD	TBD



**Maximum Ratings**

(Above which the useful life may be impaired. For user guidelines, not tested.)

Storage Temperature ..... -65°C to +150°C  
 Ambient Temperature with Power Applied..... -55°C to +125°C  
 Supply Voltage on V<sub>DD</sub> Relative to GND ..... -0.3V to +4.6V  
 DC Voltage Applied to Outputs in High Z State<sup>[11]</sup> ..... -0.5V to V<sub>DDQ</sub> + 0.5V  
 DC Input Voltage<sup>[11]</sup> ..... -0.5V to V<sub>DDQ</sub> + 0.5V

Current into Outputs (LOW) ..... 20 mA  
 Static Discharge Voltage..... >2001V (per MIL-STD-883, Method 3015)  
 Latch-Up Current..... >200 mA

**Operating Range**

Range	Ambient Temp.	V <sub>DD</sub>	V <sub>DDQ</sub>
Com'l	0°C to +70°C	3.3V -5%/+10%	2.5V - 5% 3.3V + 10%
Ind'l	-40°C to +85°C		

**Electrical Characteristics** Over the Operating Range

Parameter	Description	Test Conditions	Min.	Max.	Unit	
V <sub>DD</sub>	Power Supply Voltage		3.135	3.63	V	
V <sub>DDQ</sub>	I/O Supply Voltage		2.375	V <sub>DD</sub>	V	
V <sub>OH</sub>	Output HIGH Voltage	V <sub>DD</sub> = Min., I <sub>OH</sub> = -4.0 mA	3.3V	2.4	V	
		V <sub>DD</sub> = Min., I <sub>OH</sub> = -1.0 mA	2.5V	2.0	V	
V <sub>OL</sub>	Output LOW Voltage	V <sub>DD</sub> = Min., I <sub>OL</sub> = 8.0 mA	3.3V	0.4	V	
		V <sub>DD</sub> = Min., I <sub>OL</sub> = 1.0 mA	2.5V	0.4	V	
V <sub>IH</sub>	Input HIGH Voltage		3.3V	2.0	V <sub>DD</sub> + 0.3 V	
			2.5V	1.7	V <sub>DD</sub> + 0.3 V	
V <sub>IL</sub>	Input LOW Voltage <sup>[11]</sup>		3.3V	-0.3	0.8 V	
			2.5V	-0.3	0.7 V	
I <sub>X</sub>	Input Load Current	GND ≤ V <sub>I</sub> ≤ V <sub>DDQ</sub>	-5	5	μA	
	Input Current of MODE		-30	30	μA	
	Input Current of ZZ	Input = V <sub>SS</sub>	-30	30	μA	
I <sub>OZ</sub>	Output Leakage Current	GND ≤ V <sub>I</sub> ≤ V <sub>DDQ</sub> , Output Disabled	-5	5	μA	
I <sub>DD</sub>	V <sub>DD</sub> Operating Supply	V <sub>DD</sub> = Max., I <sub>OUT</sub> = 0 mA, f = f <sub>MAX</sub> = 1/t <sub>CYC</sub>	4.0-ns cycle, 250 MHz		350	mA
			4.4-ns cycle, 225 MHz		325	mA
			5.0-ns cycle, 200 MHz		300	mA
			6.0-ns cycle, 167 MHz		275	mA
I <sub>SB1</sub>	Automatic CE Power-Down Current—TTL Inputs	Max. V <sub>DD</sub> , Device Deselected, V <sub>IN</sub> ≥ V <sub>IH</sub> or V <sub>IN</sub> ≤ V <sub>IL</sub> , f = f <sub>MAX</sub> = 1/t <sub>CYC</sub>	4.0-ns cycle, 250 MHz		120	mA
			4.4-ns cycle, 225 MHz		110	mA
			5.0-ns cycle, 200 MHz		100	mA
			6.0-ns cycle, 167 MHz		90	mA
I <sub>SB2</sub>	Automatic CE Power-Down Current—CMOS Inputs	Max. V <sub>DD</sub> , Device Deselected, V <sub>IN</sub> ≤ 0.3V or V <sub>IN</sub> ≥ V <sub>DDQ</sub> - 0.3V, f = 0	All speed grades		70	mA
I <sub>SB3</sub>	Automatic CE Power-Down Current—CMOS Inputs	Max. V <sub>DD</sub> , Device Deselected, or V <sub>IN</sub> ≤ 0.3V or V <sub>IN</sub> ≥ V <sub>DDQ</sub> - 0.3V, f = f <sub>MAX</sub> = 1/t <sub>CYC</sub>	4.0-ns cycle, 250 MHz		105	mA
			4.4-ns cycle, 225 MHz		100	mA
			5.0-ns cycle, 200 MHz		95	mA
			6.0-ns cycle, 167 MHz		85	mA
I <sub>SB4</sub>	Automatic CS Power-Down Current—TTL Inputs	Max. V <sub>DD</sub> , Device Deselected, V <sub>IN</sub> ≥ V <sub>IH</sub> or V <sub>IN</sub> ≤ V <sub>IL</sub> , f = 0	All Speeds		80	mA

Shaded areas contain advance information.

**Note:**

11. Minimum voltage equals -2.0V for pulse durations of less than 20 ns.

**Capacitance<sup>[12]</sup>**

Parameter	Description	Test Conditions	Max.			Unit
			100-TQFP	119-BGA	165-FBGA	
$C_{IN}$	Input Capacitance	$T_A = 25^\circ\text{C}$ , $f = 1\text{ MHz}$	TBD	TBD	TBD	pF
$C_{CLK}$	Clock Input Capacitance		TBD	TBD	TBD	pF
$C_{I/O}$	Input/Output Capacitance		TBD	TBD	TBD	pF

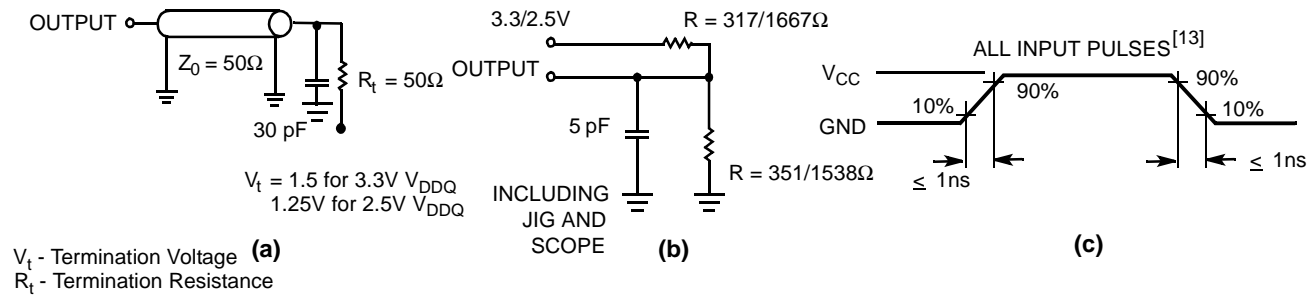
**AC Test Loads and Waveforms<sup>[13]</sup>**

**Thermal Resistance<sup>[12]</sup>**

Description	Test Conditions	Symbol	TQFP	119 BGA	165 FBGA	Units
Thermal Resistance (Junction to Ambient)	Still Air, soldered on a 3 x 4.5 inch <sup>2</sup> , 2-layer printed circuit board	$\Theta_{JA}$	31	45	46	$^\circ\text{C/W}$
Thermal Resistance (Junction to Case)		$\Theta_{JC}$	6	7	3	$^\circ\text{C/W}$

**Notes:**

12. Tested initially and after any design or process changes that may affect these parameters.
13. Input waveform should have a slew rate of  $\leq 1\text{ ns}$ .



Switching Characteristics Over the Operating Range<sup>[14, 15, 16]</sup>

Parameter	Description	-250		-225		-200		-167		Unit
		Min.	Max.	Min.	Max.	Min.	Max.	Min.	Max.	
t <sub>CYC</sub>	Clock Cycle Time	4.0		4.4		5		6		ns
t <sub>CH</sub>	Clock HIGH	1.7		2.0		2.0		2.2		ns
t <sub>CL</sub>	Clock LOW	1.7		2.0		2.0		2.2		ns
t <sub>AS</sub>	Address Set-up Before CLK Rise	1.2		1.4		1.4		1.5		ns
t <sub>AH</sub>	Address Hold After CLK Rise	0.3		0.4		0.4		0.5		ns
t <sub>CO</sub>	Data Output Valid After CLK Rise		2.6		2.8		3.0		3.4	ns
t <sub>DOH</sub>	Data Output Hold After CLK Rise	1.0		1.0		1.3		1.3		ns
t <sub>ADS</sub>	ADSP, ADSC Set-up Before CLK Rise	1.2		1.4		1.4		1.5		ns
t <sub>ADH</sub>	ADSP, ADSC Hold After CLK Rise	0.3		0.4		0.4		0.5		ns
t <sub>WES</sub>	BWE, GW, BW <sub>x</sub> Set-up Before CLK Rise	1.2		1.4		1.4		1.5		ns
t <sub>WEH</sub>	BWE, GW, BW <sub>x</sub> Hold After CLK Rise	0.3		0.4		0.4		0.5		ns
t <sub>ADVS</sub>	ADV Set-up Before CLK Rise	1.2		1.4		1.4		1.5		ns
t <sub>ADVH</sub>	ADV Hold After CLK Rise	0.3		0.4		0.4		0.5		ns
t <sub>DS</sub>	Data Input Set-Up Before CLK Rise	1.2		1.4		1.4		1.5		ns
t <sub>DH</sub>	Data Input Hold After CLK Rise	0.3		0.4		0.4		0.5		ns
t <sub>CES</sub>	Chip enable Set-up	1.2		1.4		1.4		1.5		ns
t <sub>CEH</sub>	Chip enable Hold After CLK Rise	0.3		0.4		0.4		0.5		ns
t <sub>CHZ</sub>	Clock to High-Z <sup>[15]</sup>		2.6		2.8		3.0		3.4	ns
t <sub>CLZ</sub>	Clock to Low-Z <sup>[15]</sup>	1.0		1.0		1.3		1.3		ns
t <sub>EOHZ</sub>	OE HIGH to Output High-Z <sup>[15, 16]</sup>		2.6		2.8		3.0		3.4	ns
t <sub>EOLZ</sub>	OE LOW to Output Low-Z <sup>[15, 16]</sup>	0		0		0		0		ns
t <sub>EOV</sub>	OE LOW to Output Valid <sup>[15]</sup>		2.6		2.8		3.0		3.4	ns

Shaded areas contain advance information.

Notes:

14. Unless otherwise noted, test conditions assume signal transition time of 1 ns or less, timing reference levels of 1.5/1.25V, input pulse levels of 0 to 3.0/2.5V for 3.3/2.5V V<sub>DDQ</sub> respectively, and output loading of the specified I<sub>OL</sub>/I<sub>OH</sub> and load capacitance. Shown in (a), (b) and (c) of AC Test Loads.
15. t<sub>CHZ</sub>, t<sub>CLZ</sub>, t<sub>EOV</sub>, t<sub>EOLZ</sub>, and t<sub>EOHZ</sub> are specified with a load capacitance of 5 pF as in part (b) of AC Test Loads. Transition is measured ± 200 mV from steady-state voltage.
16. At any given voltage and temperature, t<sub>EOHZ</sub> is less than t<sub>EOLZ</sub> and t<sub>CHZ</sub> is less than t<sub>CLZ</sub>.

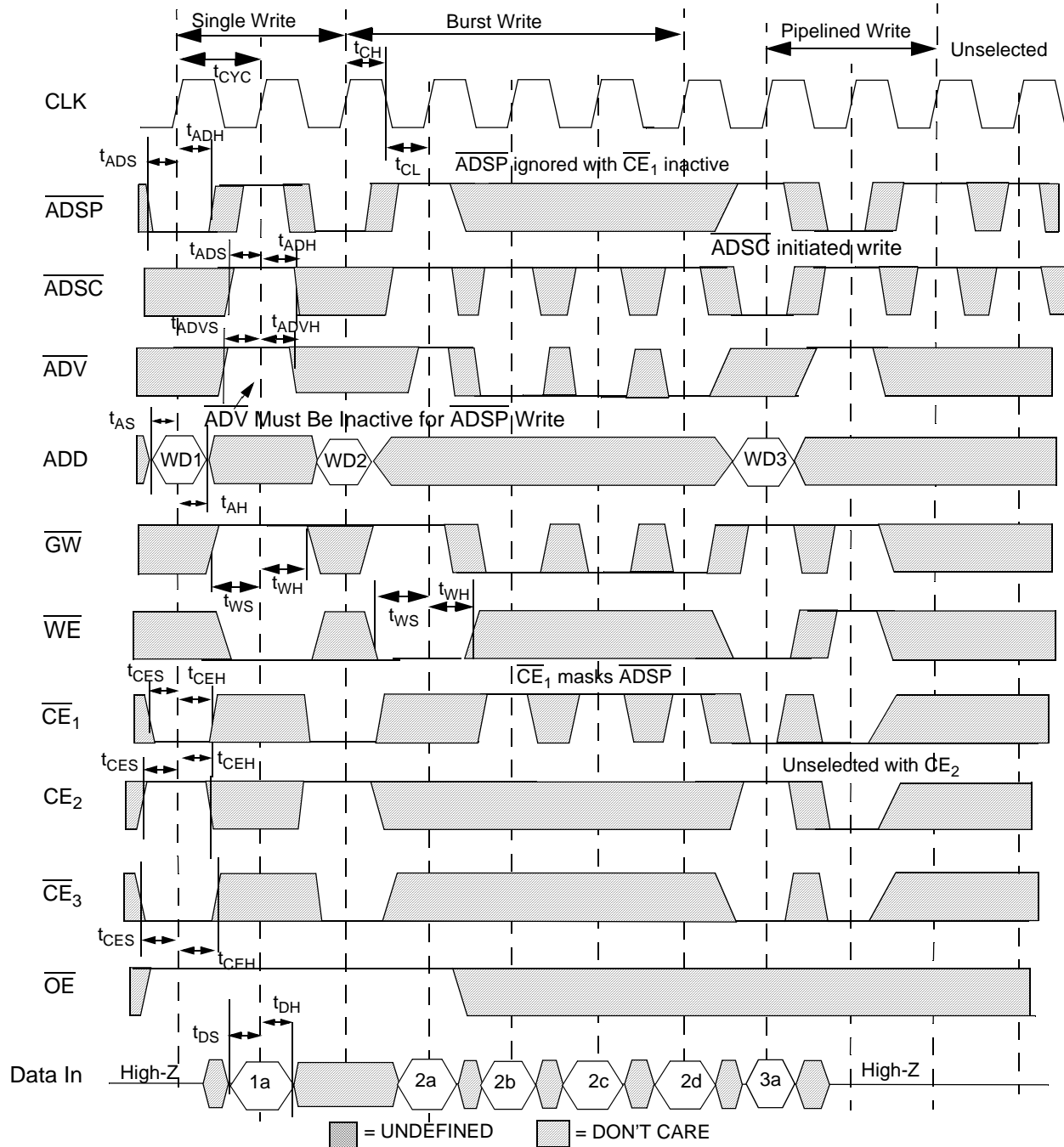

**Switching Waveforms**
**Write Cycle Timing**<sup>[4, 17, 18, 19]</sup>

**Notes:**

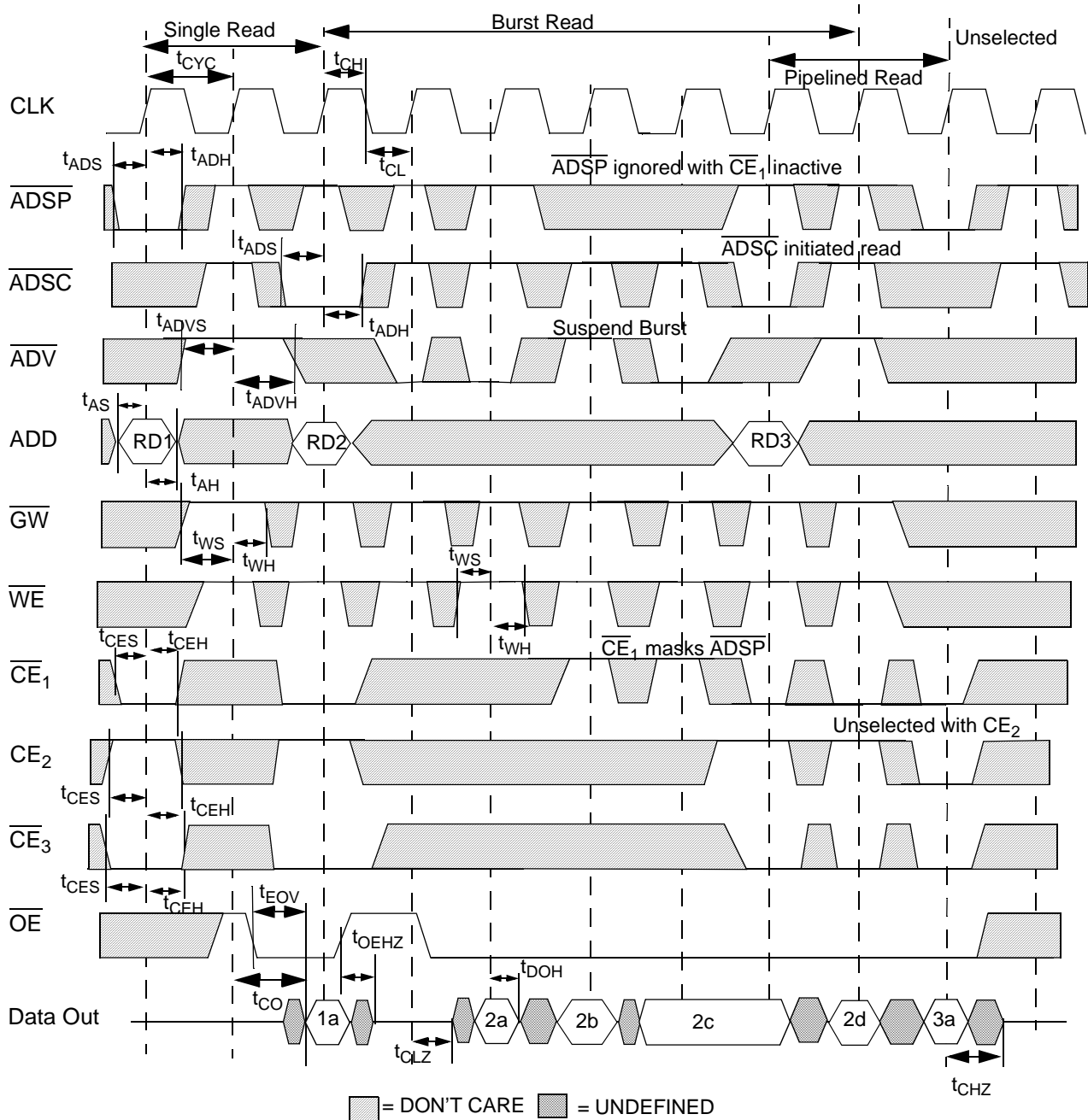
17.  $\overline{WE}$  is the combination of  $\overline{BWE}$  and  $\overline{BWx}$  to define a write cycle (see Write Cycle Descriptions table).
18.  $WDx$  stands for Write Data to Address X.
19. Device originally deselected.

**Switching Waveforms (continued)**
**Read Cycle Timing<sup>[4, 17, 19, 20]</sup>**

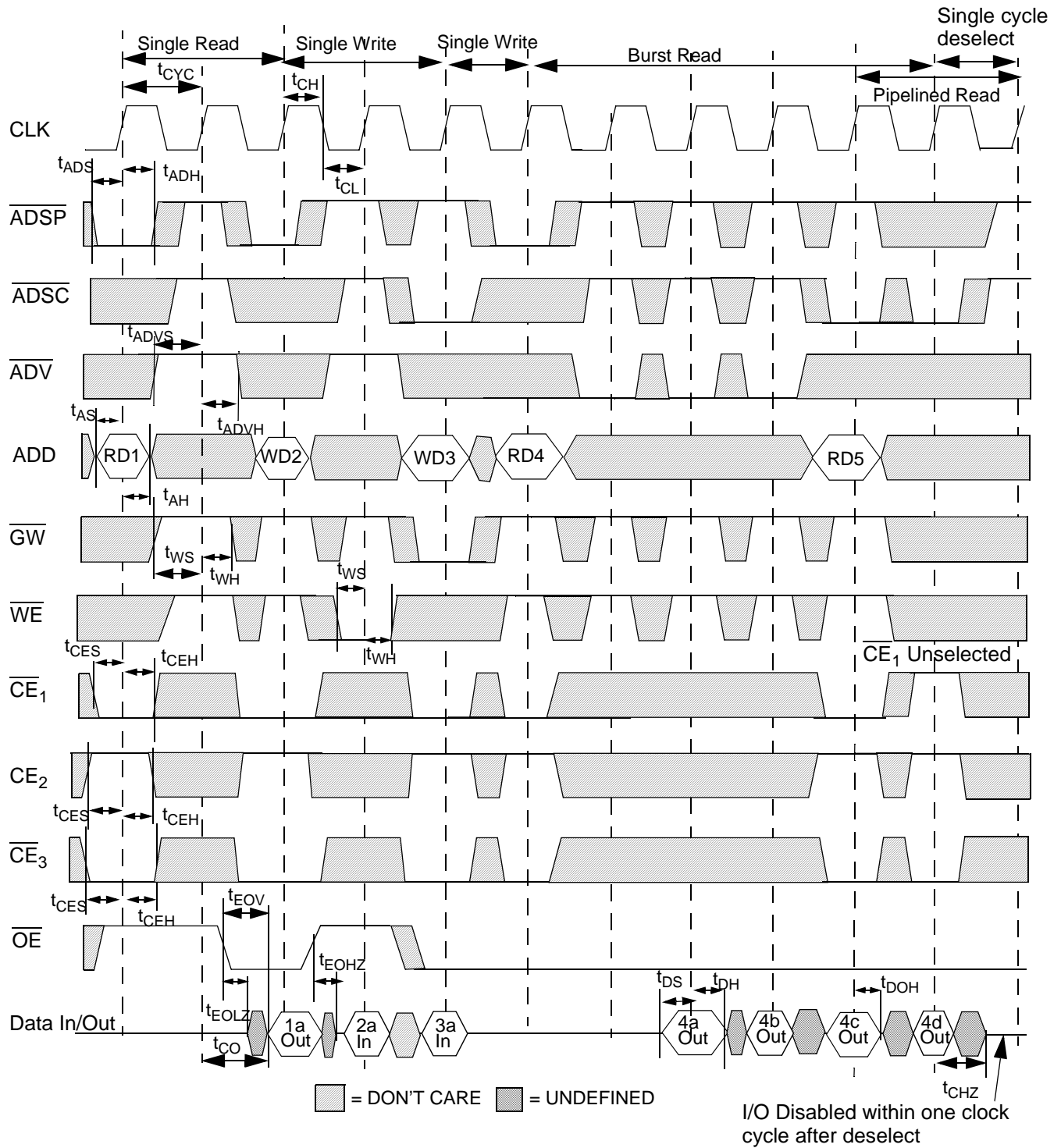
**Note:**

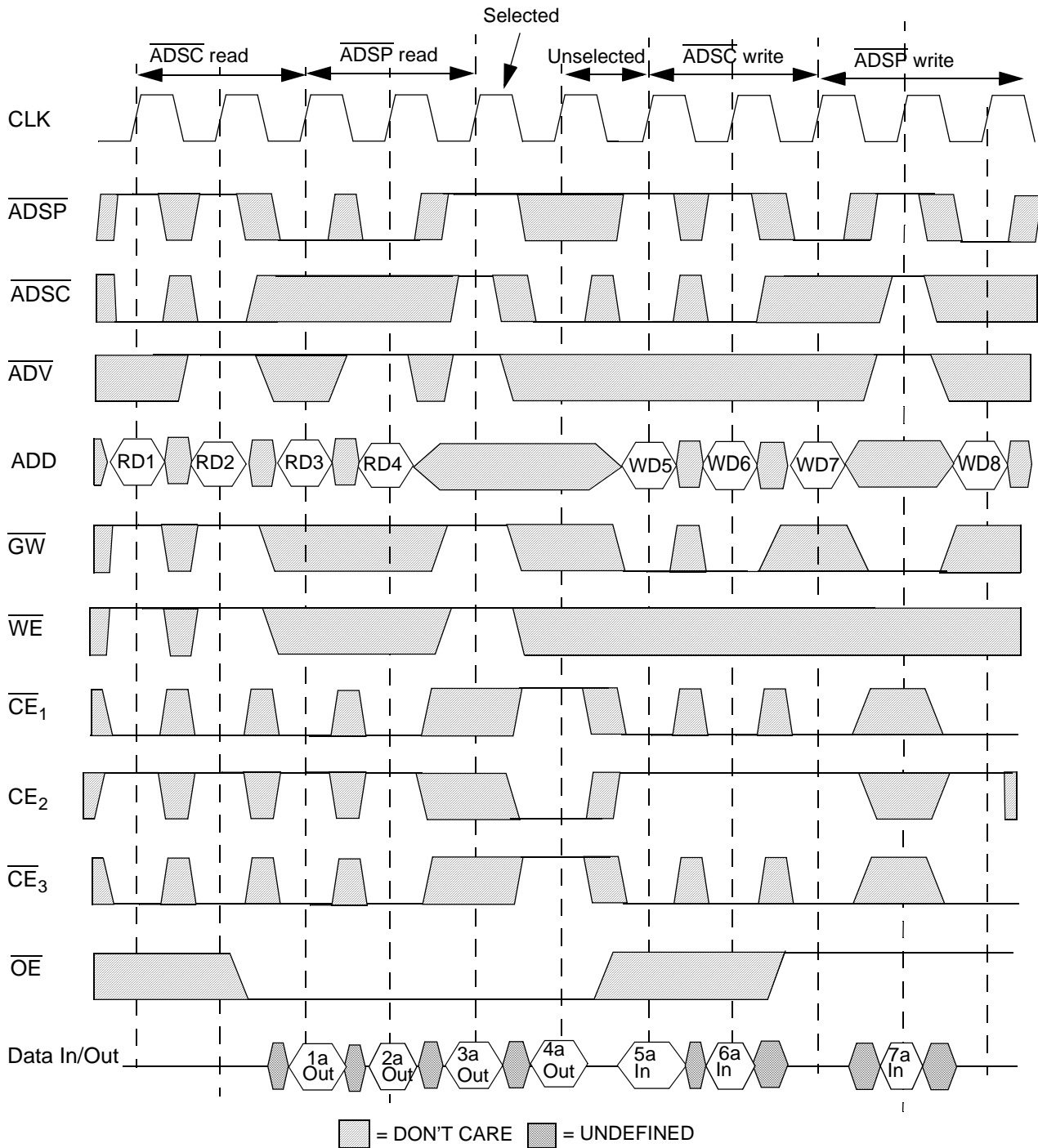
20. RDx stands for Read Data from Address X.

**Switching Waveforms (continued)**
**Read/Write Cycle Timing<sup>[4, 17, 18, 19, 20]</sup>**

**Switching Waveforms (continued)**
**Pipelined Read/Write Timing<sup>[4, 17, 18, 19, 20]</sup>**

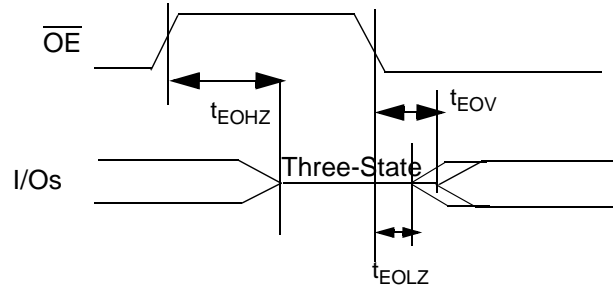
**Switching Waveforms** (continued)

**OE Switching Waveforms**

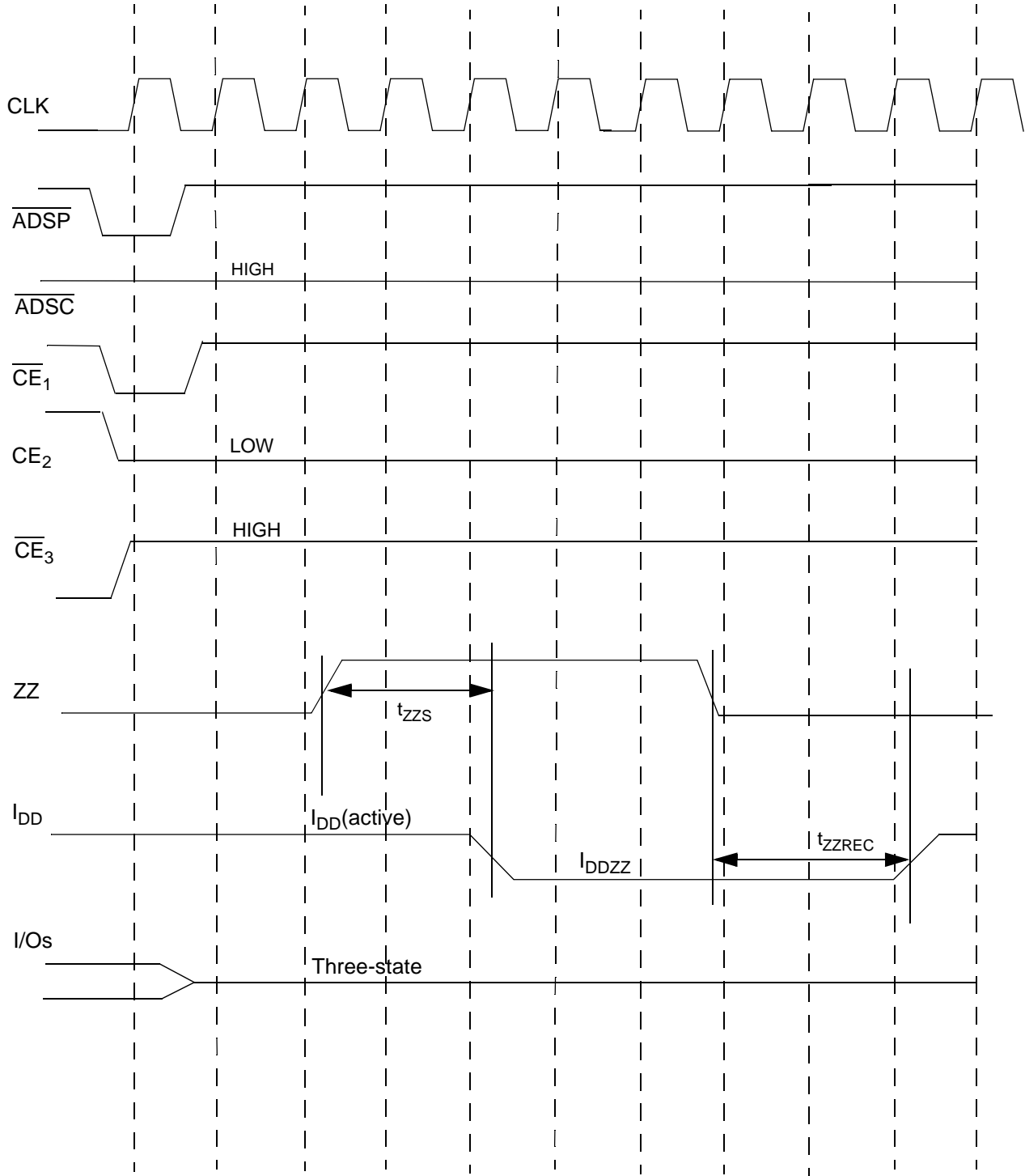
**Switching Waveforms (continued)**
**ZZ Mode Timing [4, 21, 22]**

**Notes:**

21. Device must be deselected when entering ZZ mode. See Cycle Descriptions Table for all possible signal conditions to deselect the device.
22. I/Os are in three-state when exiting ZZ sleep mode.



Ordering Information

Speed (MHz)	Ordering Code	Package Name	Package Type	Operating Range
250	CY7C1382C-250AC CY7C1380C-250AC	A101	100-Lead Thin Quad Flat Pack	Commercial
	CY7C1382C-250BGC CY7C1380C-250BGC	BG119	119 PBGA	
	CY7C1382C-250BZC CY7C1380C-250BZC	BB165A	165 FBGA	
225	CY7C1382C-225AC CY7C1380C-225AC	A101	100-Lead Thin Quad Flat Pack	
	CY7C1382C-225BGC	BG119	119 PBGA	
	CY7C1380C-225BGC	BG119	119 PBGA	
	CY7C1382C-225BZC CY7C1380C-225BZC	BB165A	165 FBGA	
200	CY7C1382C-200AC CY7C1380C-200AC	A101	100-Lead Thin Quad Flat Pack	
	CY7C1382C-200BGC CY7C1380C-200BGC	BG119	119 PBGA	
	CY7C1382C-200BZC CY7C1380C-200BZC	BB165A	165 FBGA	
167	CY7C1382C-167AC CY7C1380C-167AC	A101	100-Lead Thin Quad Flat Pack	
	CY7C1382C-167BGC	BG119	119 PBGA	
	CY7C1380C-167BGC	BG119	119 PBGA	
	CY7C1382C-167BZC CY7C1380C-167BZC	BB165A	165 FBGA	
225	CY7C1382C-225AI CY7C1380C-225AI	A101	100-Lead Thin Quad Flat Pack	Industrial
	CY7C1382C-225BGI CY7C1380C-225BGI	BG119	119 PBGA	
	CY7C1382C-225BZI CY7C1380C-225BZC	BB165A	165 FBGA	
200	CY7C1382C-200AI CY7C1380C-200AI	A101	100-Lead Thin Quad Flat Pack	
	CY7C1382C-200BGI CY7C1380C-200BGI	BG119	119 PBGA	
	CY7C1382C-200BZI CY7C1380C-200BZI	BB165A	165 FBGA	
167	CY7C1382C-167AI CY7C1380C-167AI	A101	100-Lead Thin Quad Flat Pack	
	CY7C1382C-167BGI CY7C1380C-167BGI	BG119	119 PBGA	
	CY7C1382C-167BZI CY7C1380C-167BZI	BB165A	165 FBGA	

Shaded areas contain advance information and parts that may not be offered.



Package Diagrams

100-Pin Thin Plastic Quad Flatpack (14 x 20 x 1.4 mm) A101

DIMENSIONS ARE IN MILLIMETERS.

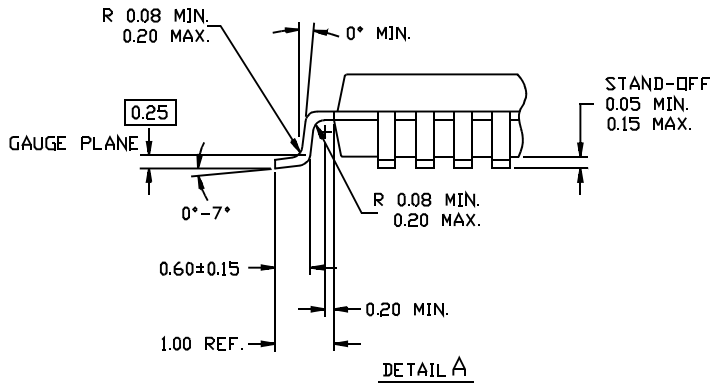
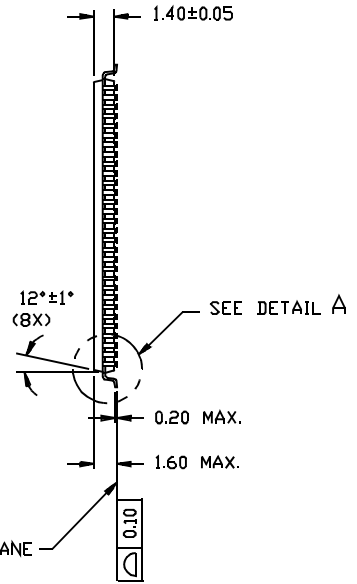
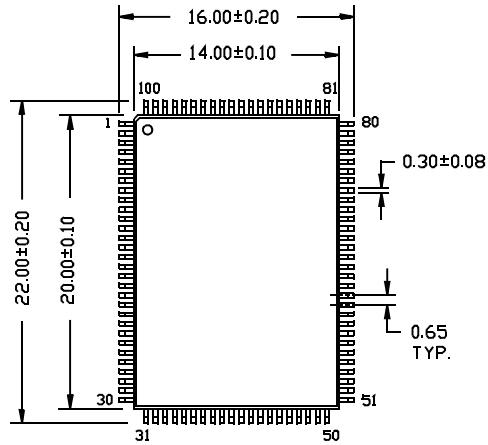

51-85050-A

Package Diagrams (continued)

119-Lead PBGA (14 x 22 x 2.4 mm) BG119

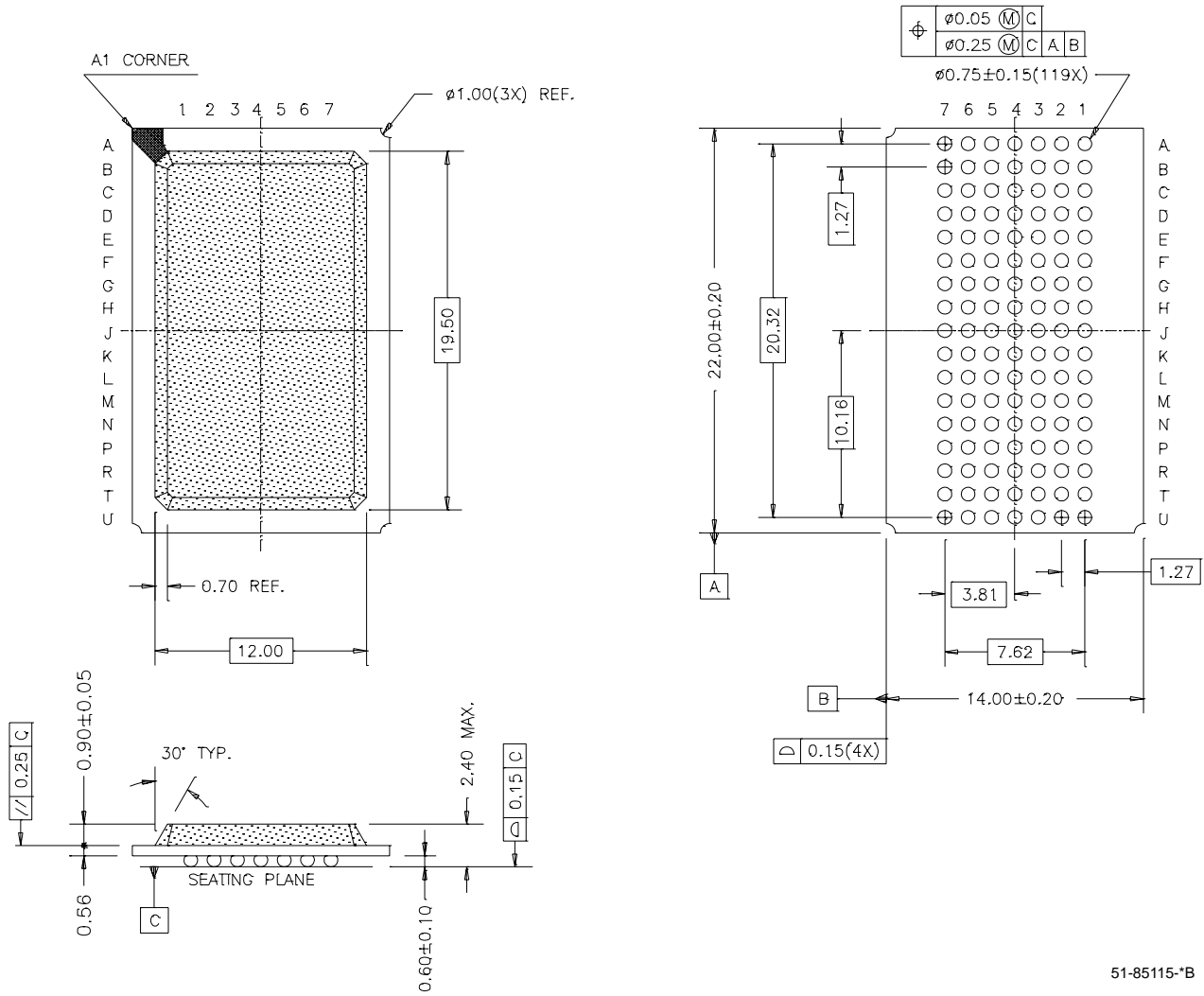

51-85115-B

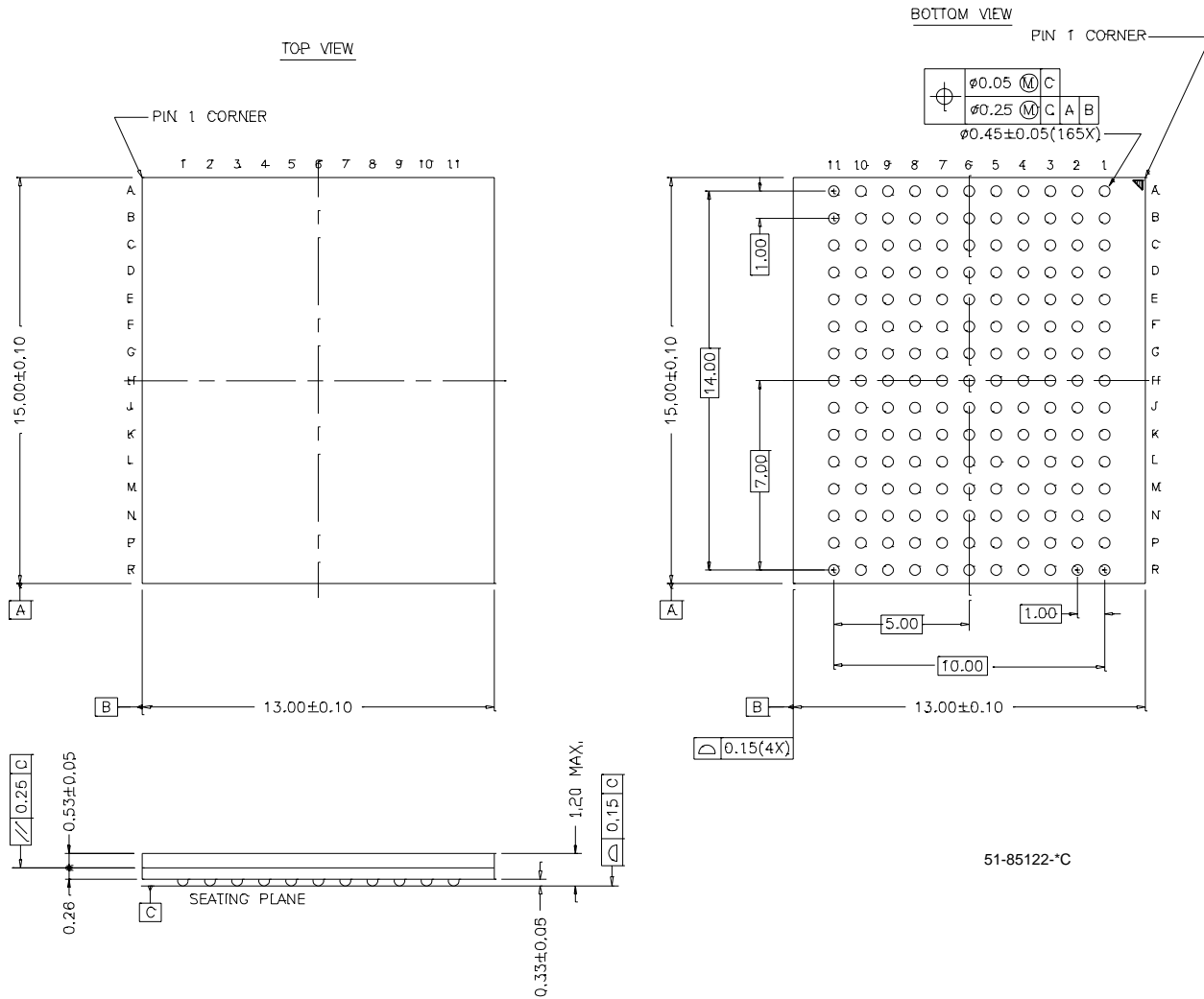
**Package Diagrams (continued)**
**165-Ball FBGA (13 x 15 x 1.2 mm) BB165A**

Intel and Pentium are registered trademarks of Intel Corporation. All product and company names mentioned in this document may be the trademarks of their respective holders.



**Document History Page**

<b>Document Title: CY7C1380C/CY7C1382C 512K x 36 / 1M x 18 Pipelined SRAM (PRELIMINARY)</b>				
<b>Document Number:38-05237</b>				
<b>Rev.</b>	<b>ECN No.</b>	<b>Issue Date</b>	<b>Orig. of Change</b>	<b>Description of Change</b>
**	116277	08/27/02	SKX	New Data Sheet
*A	121540	11/21/02	DSG	Updated package diagrams 51-85115 (BG119) to rev. *B and 51-85122 (BB165A) to rev. *C