

LOW POWER DUAL OPERATIONAL AMPLIFIERS **HWD358**

General Description

The HWD358 consists of two independent, high gain and internally frequency compensated operational amplifiers, it is specifically designed to operate from a single power supply. Operation from split power supply is also possible and the low power supply current drain is independent of the magnitude of the power supply voltages.

Features

- Internally frequency compensation
- Large voltage gain
- Low input bias current
- Low input offset voltage
- Large output voltage swing
- Wide power supply voltage range:
 Single supply 3V to 18V
 or dual supplies $\pm 1.5V$ to $\pm 9V$
- Low supply current drain: 500uA
- Compatible with industry standard 358

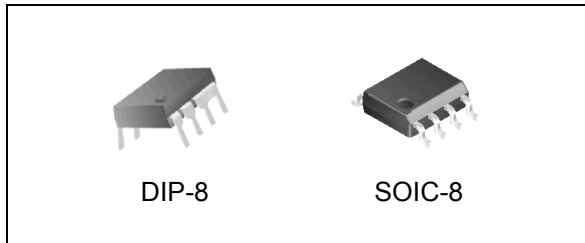

Figure 1. Package Types of HWD358

Applications

- Battery Charger
- Cordless Telephone
- Switching Power Supply

Pin Configuration

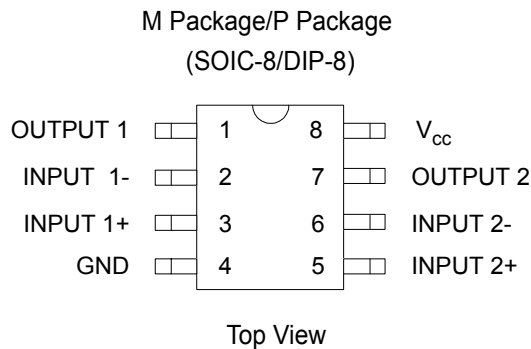

Figure 2. Pin Configuration of HWD358

Functional Block Diagram

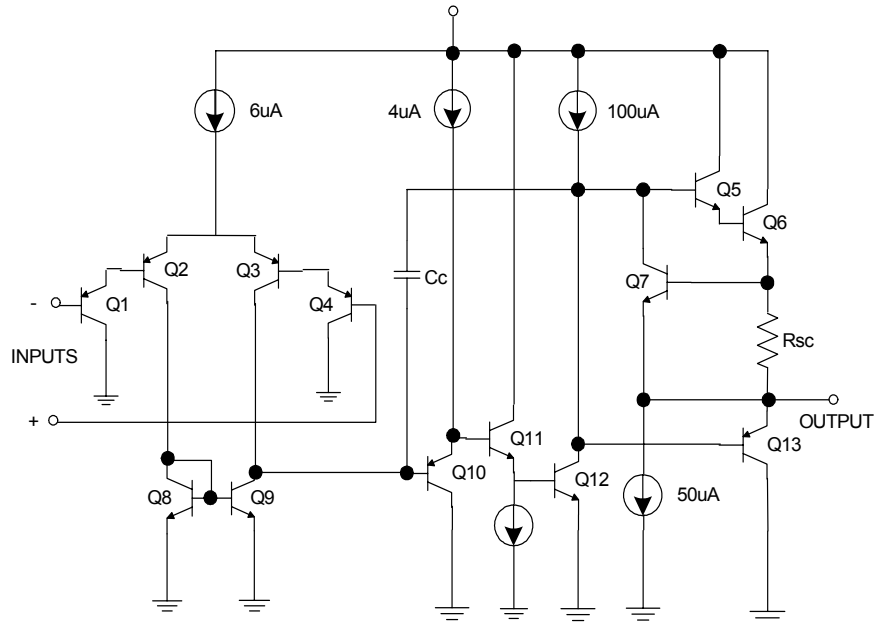

Figure 3. Functional Block Diagram of HWD358
(Each Amplifier)

Ordering Information

Package	Temperature Range	Part Number	Packing Type
SOIC-8	-40°C~85°C	HWD358M	Tube/Reel
DIP-8		HWD358P	Tube

Absolute Maximum Ratings (Note 1)

(Operation temperature range applies unless otherwise specified.)

Parameter	Symbol	Value	Unit
Power Supply Voltage	V_{CC}	20	V
Differential Input Voltage	V_{ID}	20	V
Input Voltage	V_{IC}	-0.3 to 20	V
Input Current ($V_{IN} < -0.3V$) (Note 2)	I_{IN}	50	mA
Output Short-Circuit to Ground (One Amplifier) (Note 3) $V_{CC} \leq 12V$ and $T_A = 25^\circ C$		Continuous	
Power Dissipation	P_D	DIP-8	830
		SOIC-8	550
Operating Temperature Range	T_{OP}	-40 to 85	$^\circ C$
Storage Temperature Range	T_{STG}	-65 to 150	$^\circ C$
Lead Temperature (Soldering, 10 Seconds)		260	$^\circ C$
ESD (Machine Mode)		200	V

Note 1: Stresses greater than those listed under "Absolute Maximum Ratings" may cause permanent damage to the device. These are stress ratings only, and functional operation of the device at these or any other conditions beyond those indicated under "Recommended Operation Ratings" is not implied. Exposure to "Absolute Maximum Ratings" for extended periods may affect device reliability.

Note 2: This input current will only exist when the voltage at any of the input leads is driven negative. It is due to the collector-base junction of the input PNP transistors becoming forward biased and thereby acting as input diode clamps. In addition to this diode action, there is also lateral NPN parasitic transistor action on the IC chip. This transistor action can cause the output voltages of the op amps to go to the V_{CC} voltage level (or to ground for a large overdrive) for the time duration that an input is driven negative. This is not destructive and normal output states will re-establish when the input voltage, which was negative, again returns to a value greater than -0.3V (at $25^\circ C$)

Note 3: Short circuits from the output to V_{CC} can cause excessive heating and eventual destruction. When considering short circuits to ground, the maximum output current is approximately 40mA independent of the magnitude of V_{CC} . At values of supply voltage in excess of +12V, continuous short-circuits can exceed the power dissipation ratings and cause eventual destruction. Destructive dissipation can result from simultaneous shorts on all amplifiers.

Electrical Characteristics

$V_{CC}=5V$, $GND=0$, $T_A=25^{\circ}C$ unless otherwise specified.

Parameter	Symbol	Test Conditions	Min.	Typ.	Max.	Unit
Input Offset Voltage	V_{IO}	$V_o: 1.4V, R_S: 0\Omega, V_{CC}: 5V$ to 15V		2	5	mV
Input Bias Current (Note 4)	I_{BIAS}	I_{IN+} or I_{IN-} , $V_{CM}=0V$		20	200	nA
Input Offset Current	I_{IO}	I_{IN+} or I_{IN-} , $V_{CM}=0V$		5	50	nA
Input Common Mode Voltage Range (Note 5)	V_{IR}	$V_{CC}=15V$	0		$V_{CC}-1.5$	V
Supply Current	I_{CC}	$R_L=\infty$, Over full temperature range on all OP Amps				mA
		$V_{CC}=15V$		0.7	1.5	
		$V_{CC}=5V$		0.5	1.2	
Large Signal Voltage Gain	G_V	$V_{CC}=15V$, $R_L \geq 2K$, $V_0=1V$ to 11V	80	90		dB
Common Mode Rejection Ratio	CMRR	$V_{CM}=0V$ to $(V_{CC}-1.5)V$	70	90		dB
Power Supply Rejection Ration	PSRR	$V_{CC}=5V$ to 15V	70	90		dB
Channel Separation (Note 6)	CS	$f=1KHz$ to 20KHz		-120		dB
Output Current	Source	$V_+=1V, V_-=0V$, $V_{CC}=15V, V_0=2V$	20	45		mA
	Sink	$V_+=0V, V_-=1V$, $V_{CC}=15V, V_0=2V$	10	20		mA
		$V_+=0V, V_-=1V$, $V_{CC}=15V, V_0=200mV$	12	50		uA
Short Circuit to Ground	I_{SC}	$V_{CC}=15V$		45	60	mA
Output Voltage Swing	V_{OH}	$V_{CC}=15V, R_L=2K$	12			V
		$V_{CC}=15V, R_L=10K$	12.5	13.5		
	V_{OL}	$V_{CC}=5V, R_L=10K$		5	20	mV

Note 4: The direction of the input current is out of the IC due to the PNP input stage. This current is essentially constant, independent of the state of the output so no loading change exists on the input lines.

Note 5: The input common-mode voltage of either input signal voltage should not be allowed to go negatively by more than 0.3V (at 25°C). The upper end of the common-mode voltage range is $V_{CC} - 1.5V$ (at 25°C), but either or both inputs can go to +18V without damages, independent of the magnitude of the V_{CC} .

Note 6: Due to proximity of external components, insure that coupling is not originating via stray capacitors between these external parts. This typically can be detected as this type of capacitance increases at higher frequencies.

Typical Characteristics

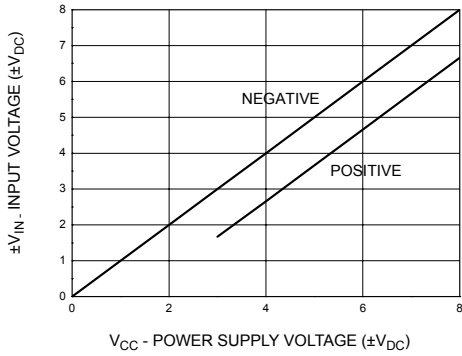

Figure 4. Input Voltage Range

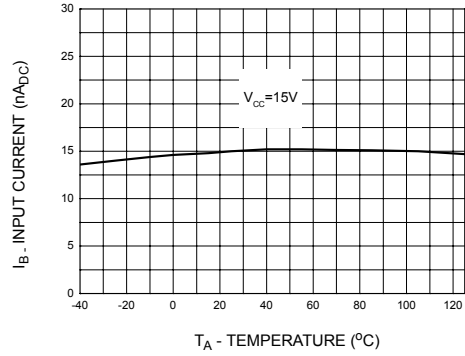

Figure 5. Input Current

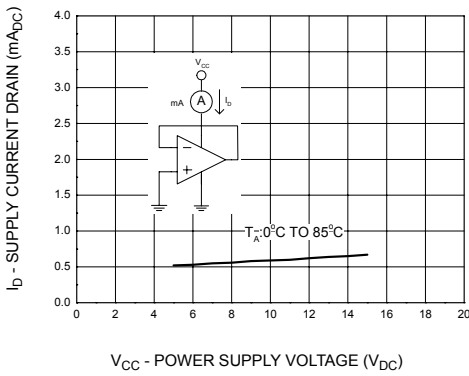

Figure 6. Supply Current

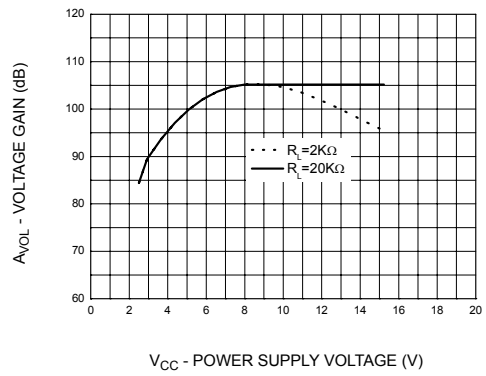

Figure 7. Voltage Gain

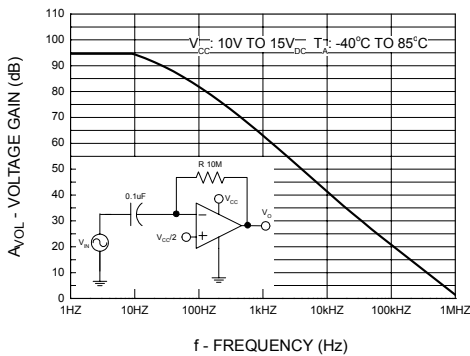

Figure 8. Open Loop Frequency Response

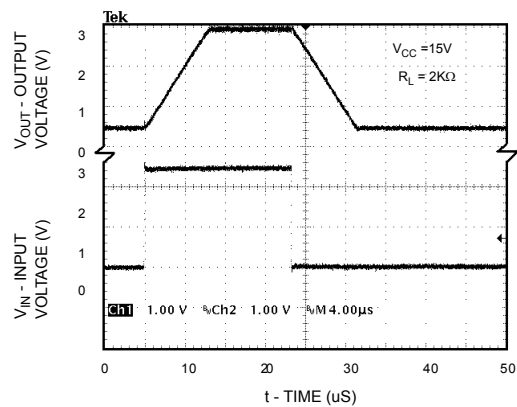

Figure 9. Voltage Follower Pulse Response

Typical Characteristics (Continued)

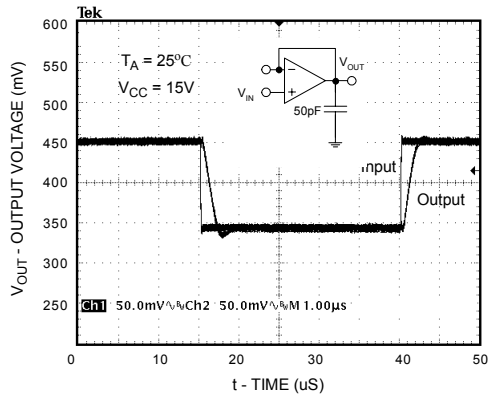

Figure 10. Voltage Follower Pulse Response (Small Signal)

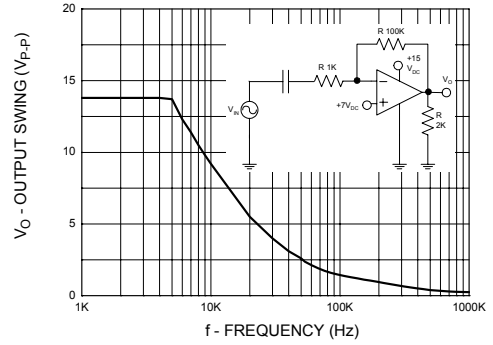

Figure 11. Large Signal Frequency Response

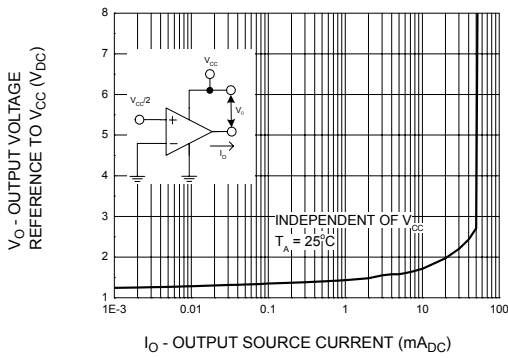

Figure 12. Output Characteristics Current Sourcing

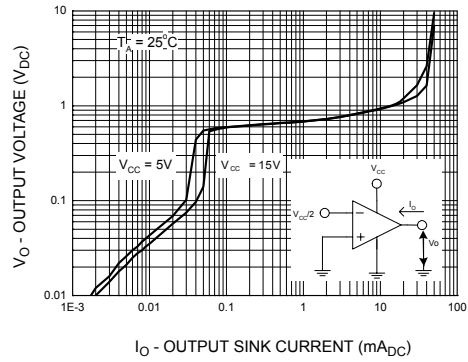

Figure 13. Output Characteristics Current Sinking

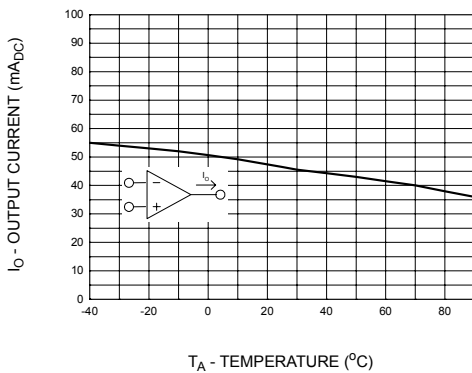

Figure 14. Current Limiting

Typical Application

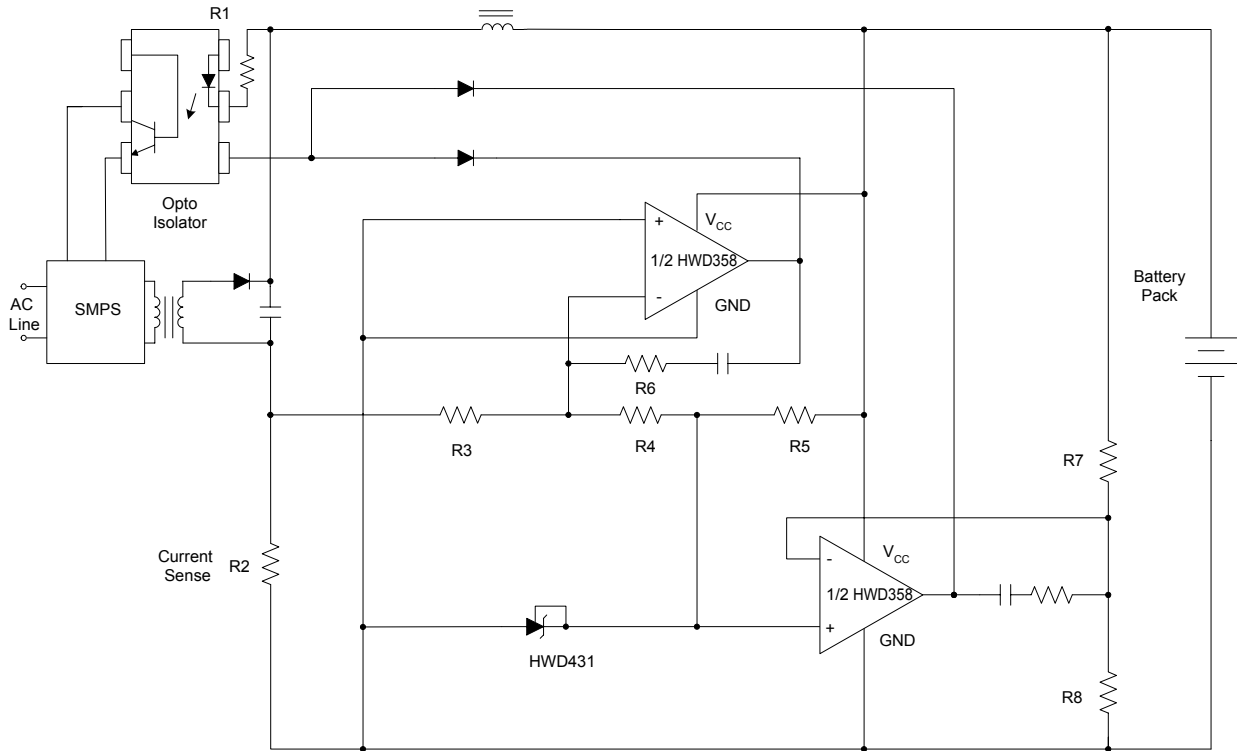

Figure 15. Battery Charger

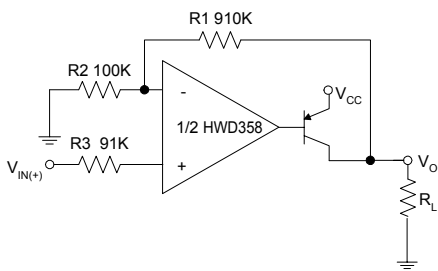

Figure 16. Power Amplifier

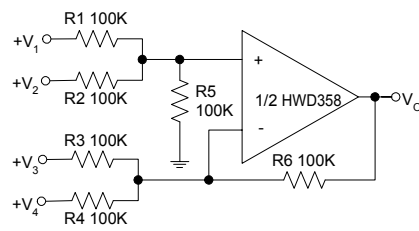

Figure 17. DC Summing Amplifier

Typical Application (Continued)

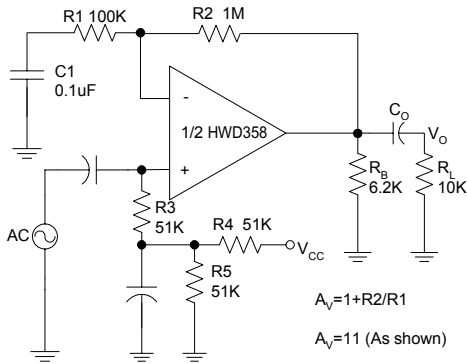

Figure 18. AC Coupled Non-Inverting Amplifier

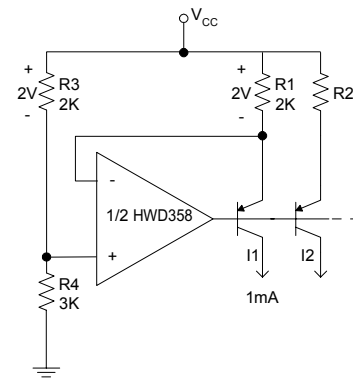

Figure 19. Fixed Current Sources

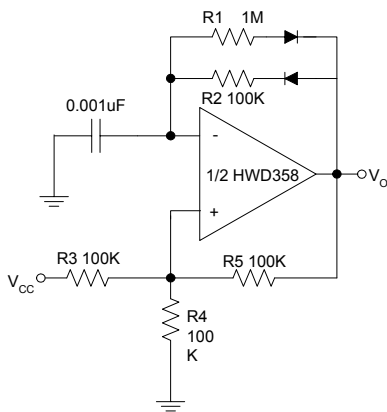

Figure 20. Pulse Generator

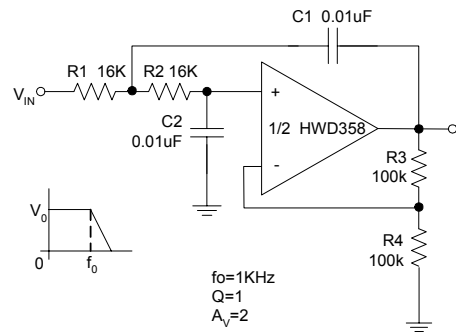
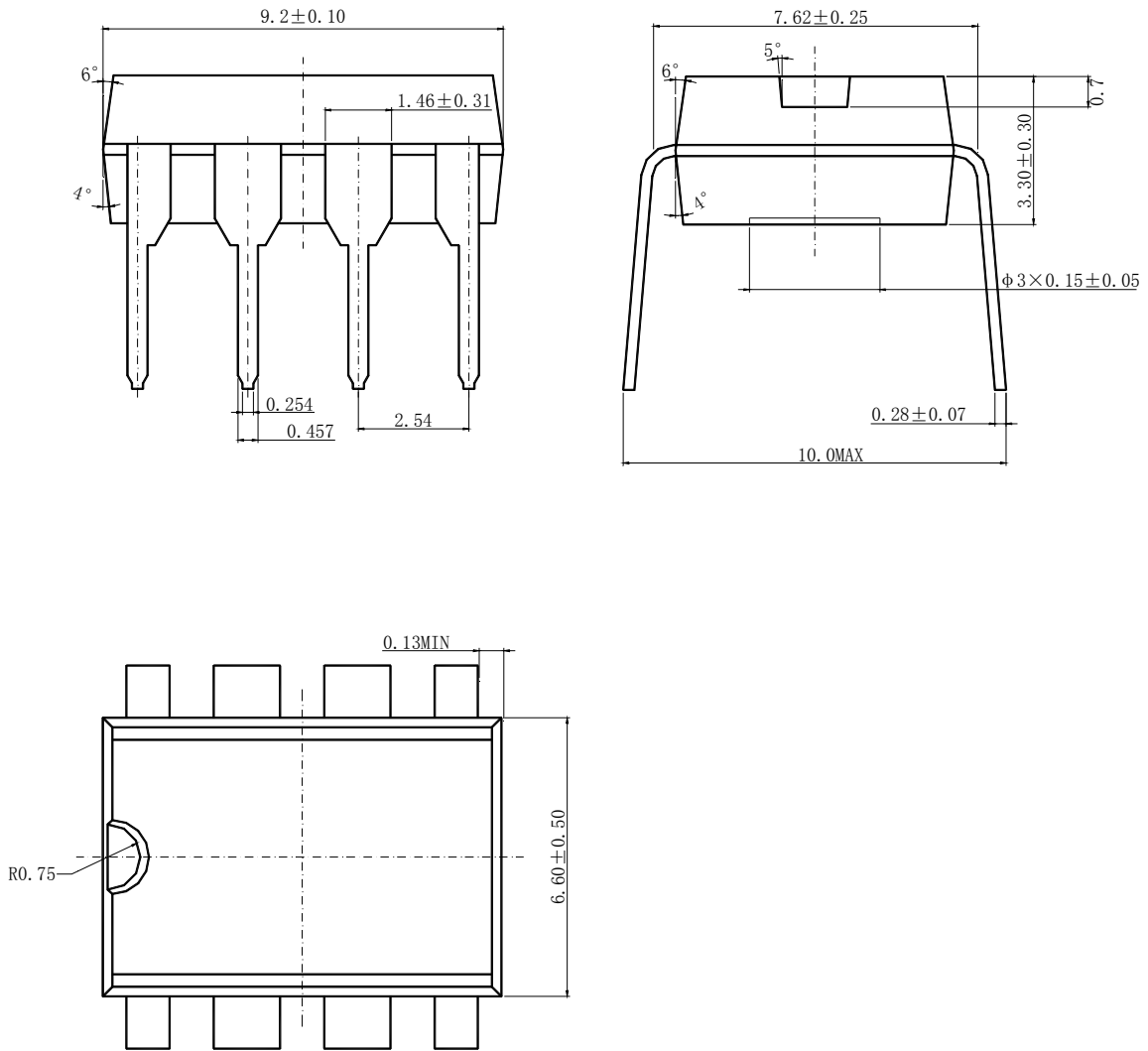

Figure 21. DC Coupled Low-Pass Active Filter

Mechanical Dimensions

DIP-8



Mechanical Dimensions (Continued)

SOIC-8

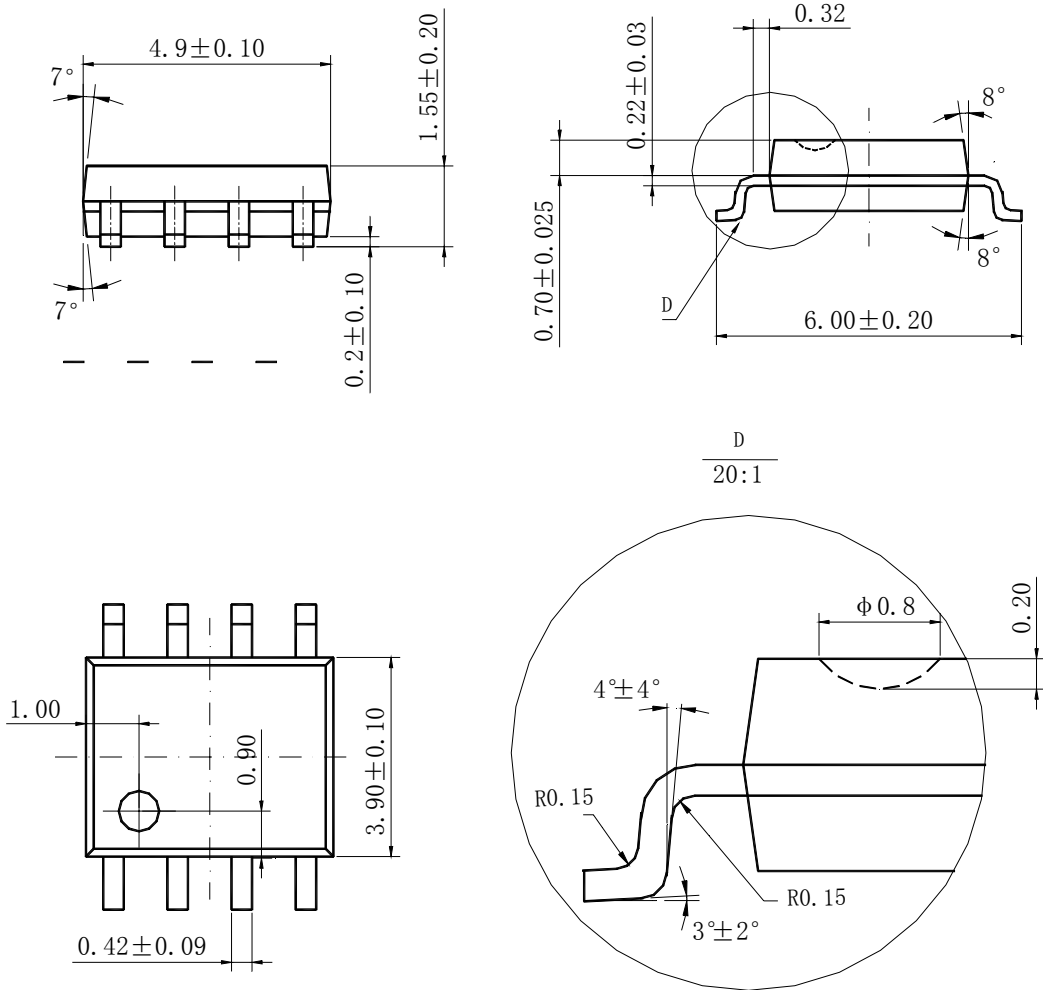

Chengdu Sino Microelectronics System Co.,Ltd

([Http://www.csmsc.com](http://www.csmsc.com))



Headquarters of CSMSC

Address: 2nd floor, Building D,
Science & Technology
Industrial Park, 11 Gaopeng
Avenue, Chengdu High-Tech
Zone, Chengdu City, Sichuan
Province, P.R.China

PC: 610041

Tel: +86-28-8517-7737

Fax: +86-28-8517-5097

Beijing Office:

Address: Room 505, No. 6 Building,
Zijin Garden, 68 Wanquanhe
Rd., Haidian District,
Beijing, P.R.China

PC: 100000

Tel: +86-10-8265-8662

Fax: +86-10-8265-8663

Shenzhen Office:

Address: Room 1110-1112, Building
A, Zhongshen Garden,
Caitian Rd., Futian District,
Shenzhen, P.R.China

PC: 518000

Tel: +86-775-8299-5768

+86-775-8299-2622

Fax: +86-775-8299-6142

+86-775-8299-1022

Shanghai Office:

Address: Room B-906, High-Tech
King World, Beijing East
Rd., Shanghai, P.R.China

PC: 200001

Tel: +86-21-5308-2272 ext. 210

+86-21-5308-2273 ext. 210

Fax: +86-21-5308-2863