

RECOMMENDED PCB LAYOUT

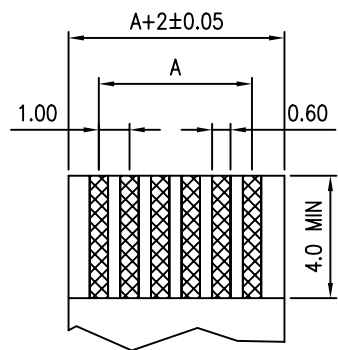
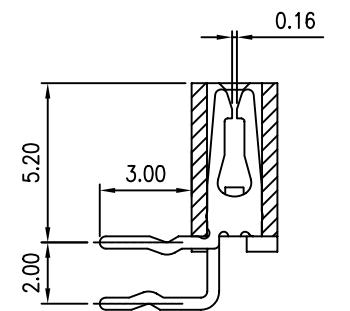

FPC/FFCT=0.30±0.05

- MATERIAL
  - INSULATOR: GLASS-REINFORCED THERMOPLASTIC.
  - CONTACT: COPPER ALLOY.
  - PLATING: TIN/LEAD PLATED OVER NICKEL
- ELECTRICAL
  - CURRENT RATING: 0.5 AMP.
  - DIELECTRIC WITHSTANDING VOLTAGE: 500 VAC MIN.
  - INSULATION RESISTANCE: 1000 MEGAOHMS MIN.
  - CONTACT RESISTANCE: 30 MILLIOHMS MAX.
- ENVIRONMENTAL
  - TEMPERATURE RANGE: -55°C TO +85°C.

■ DIMENSION TABLE

Circuits	Dimension			Circuits	Dimension		
	A	B	C		A	B	C
2	1.00	3.1	5	20	19.00	21.1	23
3	2.00	4.1	6	21	20.00	22.1	24
4	3.00	5.1	7	22	21.00	23.1	25
5	4.00	6.1	8	23	22.00	24.1	26
6	5.00	7.1	9	24	23.00	25.1	27
7	6.00	8.1	10	25	24.00	26.1	28
8	7.00	9.1	11	26	25.00	27.1	29
9	8.00	10.1	12	27	26.00	28.1	30
10	9.00	11.1	13	28	27.00	29.1	31
11	10.00	12.1	14	29	28.00	30.1	32
12	11.00	13.1	15	30	29.00	31.1	33
13	12.00	14.1	16	31	30.00	32.1	34
14	13.00	15.1	17	32	31.00	33.1	35
15	14.00	16.1	18	33	32.00	34.1	36
16	15.00	17.1	19	34	33.00	35.1	37
17	16.00	18.1	20	35	34.00	36.1	38
18	17.00	19.1	21	36	35.00	37.1	39
19	18.00	20.1	22				

**MORETHANALL**  
CONNECTORS  
ASSEMBLIES

煜倫有限公司

PART NO. FPA-RL2R-xx

DWG NO. FPA-RL2R-xx

FILE NO. GFP-232XXX-2XX0X

UNIT / mm

SCALE 1:1

APPROVED BY CY

DRAWING BY

PROJECTION

TOLERANCES ARE

.X ± 0.3  
.XX ± 0.2  
.XXX ± 0.1  
AWG

DESCRIP TION:

FPC/FFC 1.0 PITCH NON ZIF SIDE ENTRY DUAL CONTACT  
DIP TYPE - SPECIAL PCB LAYOUT

AREA

REVISIONS

HK

DATE