

#### DESCRIPTION

The LX8117/8117A/8117B series are positive Low Dropout (LDO) regulators. At the designed maximum load current, the LX8117 series dropout voltage is guaranteed to be 1.2V or lower at 0.8A (LX8117A 1.3V @ 1A). The dropout voltage decreases with load current.

An adjustable output voltage version of the LX8117/17A/17B is available, as well as versions with fixed outputs of 2.5V, 2.85V, 3.3V and 5V. The 2.85V version is specifically designed for use as a component of active termination networks for the SCSI bus. On-chip trimming of the internal voltage reference allows specification of the initial output voltage to within  $\pm 1\%$  of its nominal value. The output current-limit point is also trimmed, which helps to minimize stress on both the regulator and the system power source when they are operated under short-circuit conditions. The regulator's internal circuitry will

operate at input-to-output differential voltages down to 1V.

Most regulator circuit designs include output capacitors with values in the range of tens to hundreds of microfarads or more. The LX8117/17A/17B typically requires at least 10 $\mu$ F of output capacitance for stable operation.

PNP-type regulators can waste current equal to as much as 10 percent of their output as a quiescent current which flows directly to ground, bypassing the load. Quiescent current from the LX8117/17A/17B flows through the load, increasing power-use efficiency and allowing cooler operation.

The LX8117 is available in low-profile plastic SOT-223 and D-Pak packages for applications where space is at a premium. The LX8117 is also available in a plastic TO-263 package for instances when the thermal resistance from the circuit die to the environment must be minimized.

**NOTE:** For current data & package dimensions, visit our web site: <http://www.linfinity.com>.

#### KEY FEATURES

- 0.2% Line Regulation Maximum
- 0.4% Load Regulation Maximum
- Output Current Of 800mA
- Regulates Down To 1.2V Dropout (LX8117) And 1.3V Dropout (LX8117A)
- Operates Down To 1V Dropout
- Space Saving SOT-223 Surface Mount Package
- Guaranteed Dropout Voltage At Multiple Current Levels
- Three-Terminal Adjustable Or Fixed 2.5V, 2.85V, 3.3V & 5V

#### APPLICATIONS

- Battery Chargers
- Active SCSI Terminators
- 5V To 3.3V Linear Regulators
- High-Efficiency Linear Regulators
- Post Regulators For Switching Supplies

#### PRODUCT HIGHLIGHT

##### ACTIVE TERMINATOR FOR SCSI-2 BUS

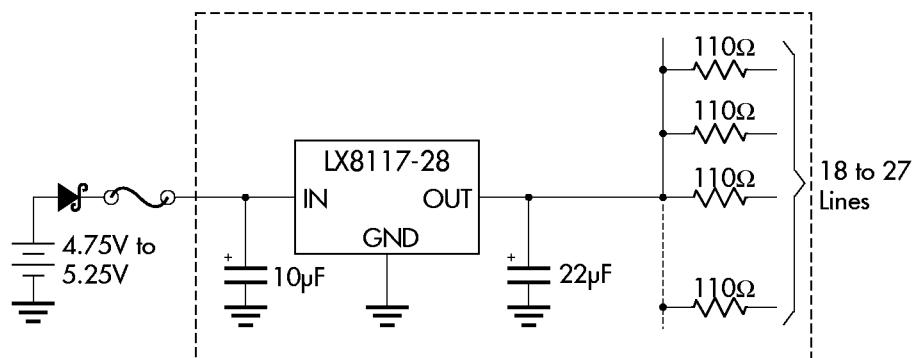

#### AVAILABLE OPTIONS PER PART #

| Part #                | Output Voltage |
|-----------------------|----------------|
| LX8117/8117A/8117B-00 | Adjustable     |
| LX8117/8117A/8117B-25 | 2.5V           |
| LX8117/8117A/8117B-28 | 2.85V          |
| LX8117/8117A/8117B-33 | 3.3V           |
| LX8117/8117A/8117B-05 | 5V             |

#### PACKAGE ORDER INFORMATION

| $T_A$ (°C) | O/P Current | ST                    | DD                   | DT                           |
|------------|-------------|-----------------------|----------------------|------------------------------|
|            |             | Plastic SOT-223 3-pin | Plastic TO-263 3-pin | Plastic TO-252 (D-Pak) 3-pin |
| 0 to 125   | 0.8A        | LX8117-xxCST          | LX8117-xxCDD         | LX8117-xxCDT                 |
|            | 1.0A        | LX8117A-xxCST         | LX8117A-xxCDD        | LX8117A-xxCDT                |
|            | 1.2A        | LX8117B-xxCST         | LX8117B-xxCDD        | LX8117B-xxCDT                |

Note: All surface-mount packages are available in Tape & Reel. Append the letter "T" to part number (i.e. LX8117-28CSTT). "xx" refers to output voltage, please see table above.

# LX8117-xx/8117A-xx/8117B-xx

## 0.8, 1 & 1.2A LOW DROPOUT POSITIVE REGULATORS

### PRODUCTION DATA SHEET

#### ABSOLUTE MAXIMUM RATINGS (Note 1)

|   |                    |
|---|--------------------|
| Power Dissipation .....   | Internally Limited |
| Input Voltage   |                    |
| LX8117-00/8117A-00/8117B-00 (Adj.) .....                                    | 15V                |
| LX8117-33/8117A-33/8117B-33 (3.3V), LX8117-05/8117A-05/8117B-05 (5.0V) .... | 15V                |
| LX8117-25/8117A-25/8117B-25 (2.5V), LX8117-28/8117A-28/8117B-28 (2.85V) ..  | 12V                |
| Surge Voltage .....   | 15V                |
| Operating Junction Temperature  |                    |
| Plastic (ST, DD & DT Packages) .....  | 150°C              |
| Storage Temperature Range .....   | -65°C to 150°C     |
| Lead Temperature (Soldering, 10 seconds) .....                              | 300°C              |
| Short-Circuit Protection .....  | Indefinite         |

Note 1. Exceeding these ratings could cause damage to the device. All voltages are with respect to Ground. Currents are positive into, negative out of the specified terminal.

#### THERMAL DATA

##### ST PACKAGE:

|   |          |
|---|----------|
| THERMAL RESISTANCE-JUNCTION TO TAB, $\theta_{JT}$     | 15°C/W   |
| THERMAL RESISTANCE-JUNCTION TO AMBIENT, $\theta_{JA}$ | *150°C/W |

##### DD PACKAGE:

|   |         |
|---|---------|
| THERMAL RESISTANCE-JUNCTION TO TAB, $\theta_{JT}$     | 10°C/W  |
| THERMAL RESISTANCE-JUNCTION TO AMBIENT, $\theta_{JA}$ | *60°C/W |

##### DT PACKAGE:

|   |         |
|---|---------|
| THERMAL RESISTANCE-JUNCTION TO TAB, $\theta_{JT}$     | 9°C/W   |
| THERMAL RESISTANCE-JUNCTION TO AMBIENT, $\theta_{JA}$ | *80°C/W |

Junction Temperature Calculation:  $T_J = T_A + (P_D \times \theta_{JA})$ . The  $\theta_{JA}$  numbers are guidelines for the thermal performance of the device/pc-board system. All of the above assume no ambient airflow.

\*  $\theta_{JA}$  can be improved with package soldered to 0.5IN<sup>2</sup> copper area over backside ground plane or internal power plane.  $\theta_{JA}$  can vary from 20°C/W to > 40°C/W depending on mounting technique. (See Application Notes Section: Thermal Considerations)

#### PACKAGE PIN OUTS

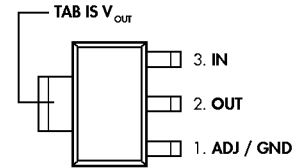

ST PACKAGE  
(Top View)

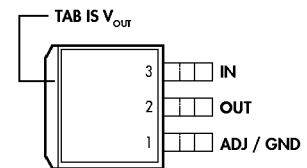

DD PACKAGE (D<sup>2</sup> Pak)  
(Top View)

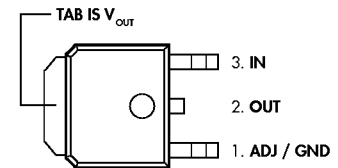

DT PACKAGE (D-Pak)  
(Top View)

#### BLOCK DIAGRAM

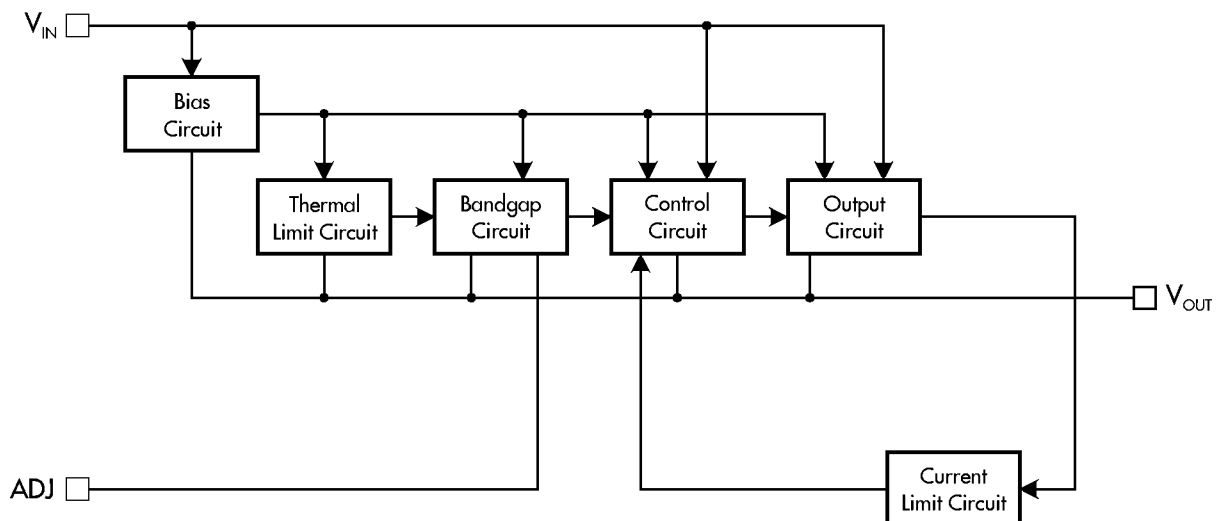

# LX8117-xx/8117A-xx/8117B-xx

## 0.8, 1 & 1.2A LOW DROPOUT POSITIVE REGULATORS

### PRODUCTION DATA SHEET

#### RECOMMENDED OPERATING CONDITIONS (Note 2)

| Parameter                           | Symbol                        | Recommended Operating Conditions |      |      | Units |
|-------------------------------------|-------------------------------|----------------------------------|------|------|-------|
|                                     |                               | Min.                             | Typ. | Max. |       |
| Input Voltage                       |                               |                                  |      |      |       |
| Operating Voltage                   | LX8117(A/B)-00 / 8117(A/B)-05 |                                  |      | 15   | V     |
|                                     | LX8117(A/B)-25 / -28 / -33    |                                  |      | 12   | V     |
| Input-Output Differential           | LX8117(A/B)-00                |                                  |      | 10   | V     |
| Operating Ambient Temperature Range |                               | 0                                |      | 125  | °C    |

Note 2. Range over which the device is functional.

#### ELECTRICAL CHARACTERISTICS

(Unless otherwise specified:  $0^{\circ}\text{C} \leq T_J \leq 125^{\circ}\text{C}$ ,  $I_{\text{MAX}} = 0.8\text{A}$  for the LX8117-xx,  $I_{\text{MAX}} = 1.0\text{A}$  for the LX8117A-xx, and  $I_{\text{MAX}} = 1.2\text{A}$  for the LX8117B-xx.)

#### LX8117-00 / 8117A-00 / 8117B-00 (Adjustable)

| Parameter                                 | Symbol                                  | Test Conditions  | LX8117 / 17A / 17B-00 |       |       | Units         |
|---|---|--|-----------------------|-------|-------|---------------|
|   |   |  | Min.                  | Typ.  | Max.  |               |
| Reference Voltage                         | $V_{\text{REF}}$                        | $I_{\text{OUT}} = 10\text{mA}$ , $(V_{\text{IN}} - V_{\text{OUT}}) = 2\text{V}$ , $T_J = 25^{\circ}\text{C}$                     | 1.238                 | 1.250 | 1.262 | V             |
|   |   | $10\text{mA} \leq I_{\text{OUT}} \leq I_{\text{OUT(MAX)}}$ , $1.4\text{V} \leq (V_{\text{IN}} - V_{\text{OUT}}) \leq 10\text{V}$ | 1.225                 | 1.250 | 1.270 | V             |
| Line Regulation (Note 3)                  | $\Delta V_{\text{REF}}(V_{\text{IN}})$  | $I_{\text{OUT}} = 10\text{mA}$ , $1.5\text{V} \leq (V_{\text{IN}} - V_{\text{OUT}}) \leq 7\text{V}$                              |                       | 0.05  | 0.2   | %             |
| Load Regulation (Note 3)                  | $\Delta V_{\text{REF}}(I_{\text{OUT}})$ | $(V_{\text{IN}} - V_{\text{OUT}}) = 3\text{V}$ , $10\text{mA} \leq I_{\text{OUT}} \leq I_{\text{OUT(MAX)}}$                      |                       | 0.15  | 0.4   | %             |
| Dropout Voltage<br>(Note 4)               | $\Delta V$                              | $I_{\text{OUT}} = 100\text{mA}$  |                       | 0.97  | 1.10  | V             |
|   |   | $I_{\text{OUT}} = 500\text{mA}$  |                       | 1.00  | 1.15  | V             |
|   |   | $I_{\text{OUT}} = I_{\text{OUT(MAX)}}$   |                       | 1.05  | 1.20  | V             |
|   |   | $I_{\text{OUT}} = I_{\text{OUT(MAX)}}$   |                       | 1.15  | 1.30  | V             |
| Current Limit                             | $I_{\text{OUT(MAX)}}$                   | $(V_{\text{IN}} - V_{\text{OUT}}) = 5\text{V}$ , $T_J = 25^{\circ}\text{C}$  | 800                   | 950   |       | mA            |
|   |   | $(V_{\text{IN}} - V_{\text{OUT}}) = 5\text{V}$ , $T_J = 25^{\circ}\text{C}$  | 1000                  | 1200  |       | mA            |
|   |   | $(V_{\text{IN}} - V_{\text{OUT}}) = 5\text{V}$ , $T_J = 25^{\circ}\text{C}$  | 1200                  | 1500  |       | mA            |
| Minimum Load Current (Note 5)             | $I_{\text{OUT(MIN)}}$                   | $V_{\text{IN}} \leq 10\text{V}$  |                       | 0.5   | 5     | mA            |
| Thermal Regulation                        | $\Delta V_{\text{OUT(PWR)}}$            | $T_A = 25^{\circ}\text{C}$ , 30ms pulse  |                       | 0.08  | 0.2   | %/W           |
| Ripple Rejection                          |   | $f_{\text{RIPPLE}} = 120\text{Hz}$ , $(V_{\text{IN}} - V_{\text{OUT}}) = 3\text{V}$ , $V_{\text{RIPPLE}} = 1\text{Vp-p}$         | 60                    | 75    |       | dB            |
| Adjust Pin Current                        | $I_{\text{ADJ}}$                        |  |                       | 45    | 100   | $\mu\text{A}$ |
| Adjust Pin Current Change                 | $\Delta I_{\text{ADJ}}$                 | $10\text{mA} \leq I_{\text{OUT}} \leq I_{\text{OUT(MAX)}}$ , $1.4\text{V} \leq (V_{\text{IN}} - V_{\text{OUT}}) \leq 10\text{V}$ |                       | 0.2   | 5     | $\mu\text{A}$ |
| Temperature Stability                     | $\Delta V_{\text{OUT}}(T)$              |  |                       | 0.5   |       | %             |
| Long Term Stability                       | $\Delta V_{\text{OUT}}(t)$              | $T_A = 125^{\circ}\text{C}$ , 1000 hours   |                       | 0.3   |       | %             |
| RMS Output Noise (% of $V_{\text{OUT}}$ ) | $V_{\text{OUT(RMS)}}$                   | $10\text{Hz} \leq f \leq 10\text{kHz}$   |                       | 0.003 |       | %             |

Notes: 3. See thermal regulation specification for changes in output voltage due to heating effects. Load regulation and line regulation are measured at a constant junction temperature by low duty cycle pulse testing.

4. Dropout voltage is specified over the full output current range of the device. Dropout voltage is defined as the minimum input/output differential measured at the specified output current. Test points and limits are also shown on the Dropout Voltage Curve.

5. Minimum load current is defined as the minimum output current required to maintain regulation.

(Other Voltage Options on following pages.)

# LX8117-xx/8117A-xx/8117B-xx

## 0.8, 1 & 1.2A LOW DROPOUT POSITIVE REGULATORS

### PRODUCTION DATA SHEET

#### ELECTRICAL CHARACTERISTICS (continued)

##### LX8117-25 / 8117A-25 / 8117B-25 (2.5V Fixed)

| Parameter                          | Symbol                    | Test Conditions   | LX8117 / 17A / 17B-25 |       |       | Units |
|------------------------------------|---------------------------|---|-----------------------|-------|-------|-------|
|                                    |                           |   | Min.                  | Typ.  | Max.  |       |
| Output Voltage                     | $V_{OUT}$                 | $I_{OUT} = 10mA, V_{IN} = 5V, T_A = 25^\circ C$                   | 2.475                 | 2.500 | 2.525 | V     |
|                                    |                           | $0mA \leq I_{OUT} \leq I_{OUT(MAX)}, 4.75V \leq V_{IN} \leq 10V$  | 2.450                 | 2.500 | 2.550 | V     |
| Line Regulation (Note 3)           | $\Delta V_{OUT}(V_{IN})$  | $I_{OUT} = 0mA, 4.25V \leq V_{IN} \leq 10V$                       |                       | 1     | 6     | mV    |
| Load Regulation (Note 3)           | $\Delta V_{OUT}(I_{OUT})$ | $V_{IN} = 4.25V, 0mA \leq I_{OUT} \leq I_{OUT(MAX)}$              |                       | 2     | 10    | mV    |
| Dropout Voltage<br>(Note 4)        | $\Delta V$                | $I_{OUT} = 100mA$   |                       | 0.97  | 1.10  | V     |
|                                    |                           | $I_{OUT} = 500mA$   |                       | 1.00  | 1.15  | V     |
|                                    |                           | $I_{OUT} = I_{OUT(MAX)}$  |                       | 1.05  | 1.20  | V     |
|                                    |                           | $I_{OUT} = I_{OUT(MAX)}$  |                       | 1.15  | 1.30  | V     |
| Current Limit                      | $I_{OUT(MAX)}$            | $(V_{IN} - V_{OUT}) = 5V, T_J = 25^\circ C$                       | 800                   | 950   |       | mA    |
|                                    |                           | $(V_{IN} - V_{OUT}) = 5V, T_J = 25^\circ C$                       | 1000                  | 1200  |       | mA    |
|                                    |                           | $(V_{IN} - V_{OUT}) = 5V, T_J = 25^\circ C$                       | 1200                  | 1500  |       | mA    |
| Quiescent Current                  | $I_Q$                     | $V_{IN} \leq 10V$   |                       | 4.5   | 10    | mA    |
| Thermal Regulation                 | $\Delta V_{OUT(PWR)}$     | $T_A = 25^\circ C, 30ms$ pulse                                    |                       | 0.08  | 0.2   | %/W   |
| Ripple Rejection                   |                           | $f_{RIPPLE} = 120Hz, (V_{IN} - V_{OUT}) = 3V, V_{RIPPLE} = 1Vp-p$ | 60                    | 75    |       | dB    |
| Temperature Stability              | $\Delta V_{OUT}(T)$       |   |                       | 0.5   |       | %     |
| Long Term Stability                | $\Delta V_{OUT}(t)$       | $T_A = 125^\circ C, 1000$ hours                                   |                       | 0.3   |       | %     |
| RMS Output Noise (% of $V_{OUT}$ ) | $V_{OUT(RMS)}$            | $10Hz \leq f \leq 10kHz$  |                       | 0.003 |       | %     |

##### LX8117-28 / 8117A-28 / 8117B-28 (2.8V Fixed)

| Parameter                          | Symbol                    | Test Conditions   | LX8117 / 17A / 17B-28 |       |       | Units |
|------------------------------------|---------------------------|---|-----------------------|-------|-------|-------|
|                                    |                           |   | Min.                  | Typ.  | Max.  |       |
| Output Voltage                     | $V_{OUT}$                 | $I_{OUT} = 10mA, V_{IN} = 4.85V, T_A = 25^\circ C$                | 2.820                 | 2.850 | 2.880 | V     |
|                                    |                           | $0mA \leq I_{OUT} \leq I_{OUT(MAX)}, 4.25V \leq V_{IN} \leq 10V$  | 2.790                 | 2.850 | 2.910 | V     |
|                                    |                           | $0mA \leq I_{OUT} \leq 500mA, V_{IN} = 3.95V$                     | 2.790                 | 2.850 | 2.910 | V     |
| Line Regulation (Note 3)           | $\Delta V_{OUT}(V_{IN})$  | $I_{OUT} = 0mA, 4.25V \leq V_{IN} \leq 10V$                       |                       | 1     | 6     | mV    |
| Load Regulation (Note 3)           | $\Delta V_{OUT}(I_{OUT})$ | $V_{IN} = 4.25V, 0mA \leq I_{OUT} \leq I_{OUT(MAX)}$              |                       | 2     | 10    | mV    |
| Dropout Voltage<br>(Note 4)        | $\Delta V$                | $I_{OUT} = 100mA$   |                       | 0.97  | 1.10  | V     |
|                                    |                           | $I_{OUT} = 500mA$   |                       | 1.00  | 1.15  | V     |
|                                    |                           | $I_{OUT} = I_{OUT(MAX)}$  |                       | 1.05  | 1.20  | V     |
|                                    |                           | $I_{OUT} = I_{OUT(MAX)}$  |                       | 1.15  | 1.30  | V     |
| Current Limit                      | $I_{OUT(MAX)}$            | $(V_{IN} - V_{OUT}) = 5V, T_J = 25^\circ C$                       | 800                   | 950   |       | mA    |
|                                    |                           | $(V_{IN} - V_{OUT}) = 5V, T_J = 25^\circ C$                       | 1000                  | 1200  |       | mA    |
|                                    |                           | $(V_{IN} - V_{OUT}) = 5V, T_J = 25^\circ C$                       | 1200                  | 1500  |       | mA    |
| Quiescent Current                  | $I_Q$                     | $V_{IN} \leq 10V$   |                       | 4.5   | 10    | mA    |
| Thermal Regulation                 | $\Delta V_{OUT(PWR)}$     | $T_A = 25^\circ C, 30ms$ pulse                                    |                       | 0.08  | 0.2   | %/W   |
| Ripple Rejection                   |                           | $f_{RIPPLE} = 120Hz, (V_{IN} - V_{OUT}) = 3V, V_{RIPPLE} = 1Vp-p$ | 60                    | 75    |       | dB    |
| Temperature Stability              | $\Delta V_{OUT}(T)$       |   |                       | 0.5   |       | %     |
| Long Term Stability                | $\Delta V_{OUT}(t)$       | $T_A = 125^\circ C, 1000$ hours                                   |                       | 0.3   |       | %     |
| RMS Output Noise (% of $V_{OUT}$ ) | $V_{OUT(RMS)}$            | $10Hz \leq f \leq 10kHz$  |                       | 0.003 |       | %     |

- Notes:
- See thermal regulation specification for changes in output voltage due to heating effects. Load regulation and line regulation are measured at a constant junction temperature by low duty cycle pulse testing.
  - Dropout voltage is specified over the full output current range of the device. Dropout voltage is defined as the minimum input/output differential measured at the specified output current. Test points and limits are also shown on the Dropout Voltage Curve.
  - Minimum load current is defined as the minimum output current required to maintain regulation.

# LX8117-xx/8117A-xx/8117B-xx

## 0.8, 1 & 1.2A LOW DROPOUT POSITIVE REGULATORS

### PRODUCTION DATA SHEET

#### ELECTRICAL CHARACTERISTICS (continued)

##### LX8117-33 / 8117A-33 / 8117B-33 (3.3V Fixed)

| Parameter                          | Symbol                    | Test Conditions   | LX8117 / 17A / 17B-33 |       |       | Units |
|------------------------------------|---------------------------|---|-----------------------|-------|-------|-------|
|                                    |                           |   | Min.                  | Typ.  | Max.  |       |
| Output Voltage                     | $V_{OUT}$                 | $I_{OUT} = 10mA, V_{IN} = 5V, T_A = 25^\circ C$                   | 3.267                 | 3.300 | 3.333 | V     |
|                                    |                           | $0mA \leq I_{OUT} \leq I_{OUT(MAX)}, 4.75V \leq V_{IN} \leq 10V$  | 3.235                 | 3.300 | 3.365 | V     |
| Line Regulation (Note 3)           | $\Delta V_{OUT}(V_{IN})$  | $I_{OUT} = 0mA, 4.25V \leq V_{IN} \leq 10V$                       |                       | 1     | 6     | mV    |
| Load Regulation (Note 3)           | $\Delta V_{OUT}(I_{OUT})$ | $V_{IN} = 4.25V, 0mA \leq I_{OUT} \leq I_{OUT(MAX)}$              |                       | 2     | 10    | mV    |
| Dropout Voltage<br>(Note 4)        | $\Delta V$                | $I_{OUT} = 100mA$   |                       | 0.97  | 1.10  | V     |
|                                    |                           | $I_{OUT} = 500mA$   |                       | 1.00  | 1.15  | V     |
|                                    |                           | $I_{OUT} = I_{OUT(MAX)}$  |                       | 1.05  | 1.20  | V     |
|                                    |                           | $I_{OUT} = I_{OUT(MAX)}$  |                       | 1.15  | 1.30  | V     |
| Current Limit                      | $I_{OUT(MAX)}$            | $(V_{IN} - V_{OUT}) = 5V, T_J = 25^\circ C$                       | 800                   | 950   |       | mA    |
|                                    |                           | $(V_{IN} - V_{OUT}) = 5V, T_J = 25^\circ C$                       | 1000                  | 1200  |       | mA    |
|                                    |                           | $(V_{IN} - V_{OUT}) = 5V, T_J = 25^\circ C$                       | 1200                  | 1500  |       | mA    |
| Quiescent Current                  | $I_Q$                     | $V_{IN} \leq 10V$   |                       | 4.5   | 10    | mA    |
| Thermal Regulation                 | $\Delta V_{OUT}(PWR)$     | $T_A = 25^\circ C, 30ms$ pulse                                    |                       | 0.08  | 0.2   | %/W   |
| Ripple Rejection                   |                           | $f_{RIPPLE} = 120Hz, (V_{IN} - V_{OUT}) = 3V, V_{RIPPLE} = 1Vp-p$ | 60                    | 75    |       | dB    |
| Temperature Stability              | $\Delta V_{OUT}(T)$       |   |                       | 0.5   |       | %     |
| Long Term Stability                | $\Delta V_{OUT}(t)$       | $T_A = 125^\circ C, 1000$ hours                                   |                       | 0.3   |       | %     |
| RMS Output Noise (% of $V_{OUT}$ ) | $V_{OUT(RMS)}$            | $10Hz \leq f \leq 10kHz$  |                       | 0.003 |       | %     |

##### LX8117-05 / 8117A-05 / 8117B-05 (5.0V Fixed)

| Parameter                          | Symbol                    | Test Conditions   | LX8117 / 17A / 17B-05 |       |       | Units |
|------------------------------------|---------------------------|---|-----------------------|-------|-------|-------|
|                                    |                           |   | Min.                  | Typ.  | Max.  |       |
| Output Voltage                     | $V_{OUT}$                 | $I_{OUT} = 10mA, V_{IN} = 7V, T_A = 25^\circ C$                   | 4.950                 | 5.000 | 5.050 | V     |
|                                    |                           | $0mA \leq I_{OUT} \leq I_{OUT(MAX)}, 6.50V \leq V_{IN} \leq 10V$  | 4.900                 | 5.000 | 5.100 | V     |
| Line Regulation (Note 3)           | $\Delta V_{OUT}(V_{IN})$  | $I_{OUT} = 0mA, 6.5V \leq V_{IN} \leq 10V$                        |                       | 1     | 10    | mV    |
| Load Regulation (Note 3)           | $\Delta V_{OUT}(I_{OUT})$ | $V_{IN} = 6.5V, 0mA \leq I_{OUT} \leq I_{OUT(MAX)}$               |                       | 2.5   | 15    | mV    |
| Dropout Voltage<br>(Note 4)        | $\Delta V$                | $I_{OUT} = 100mA$   |                       | 0.97  | 1.10  | V     |
|                                    |                           | $I_{OUT} = 500mA$   |                       | 1.00  | 1.15  | V     |
|                                    |                           | $I_{OUT} = I_{OUT(MAX)}$  |                       | 1.05  | 1.20  | V     |
|                                    |                           | $I_{OUT} = I_{OUT(MAX)}$  |                       | 1.15  | 1.30  | V     |
| Current Limit                      | $I_{OUT(MAX)}$            | $(V_{IN} - V_{OUT}) = 5V, T_J = 25^\circ C$                       | 800                   | 950   |       | mA    |
|                                    |                           | $(V_{IN} - V_{OUT}) = 5V, T_J = 25^\circ C$                       | 1000                  | 1200  |       | mA    |
|                                    |                           | $(V_{IN} - V_{OUT}) = 5V, T_J = 25^\circ C$                       | 1200                  | 1500  |       | mA    |
| Quiescent Current                  | $I_Q$                     | $V_{IN} \leq 10V$   |                       | 4.5   | 10    | mA    |
| Thermal Regulation                 | $\Delta V_{OUT}(PWR)$     | $T_A = 25^\circ C, 30ms$ pulse                                    |                       | 0.08  | 0.2   | %/W   |
| Ripple Rejection                   |                           | $f_{RIPPLE} = 120Hz, (V_{IN} - V_{OUT}) = 3V, V_{RIPPLE} = 1Vp-p$ | 60                    | 75    |       | dB    |
| Temperature Stability              | $\Delta V_{OUT}(T)$       |   |                       | 0.5   |       | %     |
| Long Term Stability                | $\Delta V_{OUT}(t)$       | $T_A = 125^\circ C, 1000$ hours                                   |                       | 0.3   |       | %     |
| RMS Output Noise (% of $V_{OUT}$ ) | $V_{OUT(RMS)}$            | $10Hz \leq f \leq 10kHz$  |                       | 0.003 |       | %     |

- Notes:
- See thermal regulation specification for changes in output voltage due to heating effects. Load regulation and line regulation are measured at a constant junction temperature by low duty cycle pulse testing.
  - Dropout voltage is specified over the full output current range of the device. Dropout voltage is defined as the minimum input/output differential measured at the specified output current. Test points and limits are also shown on the Dropout Voltage Curve.
  - Minimum load current is defined as the minimum output current required to maintain regulation.

# LX8117-xx/8117A-xx/8117B-xx

## 0.8, 1 & 1.2A LOW DROPOUT POSITIVE REGULATORS

### PRODUCTION DATA SHEET

#### APPLICATION NOTES

The LX8117 series ICs are easy to use Low-Dropout (LDO) voltage regulators. They have all of the standard self-protection features expected of a voltage regulator: short circuit protection, safe operating area protection and automatic thermal shutdown if the device temperature rises above approximately 165°C.

Use of an output capacitor is REQUIRED with the LX8117 series. Please see the table below for recommended minimum capacitor values.

These regulators offer a more tightly controlled reference voltage tolerance and superior reference stability when measured against the older pin-compatible regulator types that they replace.

#### STABILITY

The output capacitor is part of the regulator's frequency compensation system. Many types of capacitors are available, with different capacitance value tolerances, capacitance temperature coefficients, and equivalent series impedances. For all operating conditions, connection of a 220µF aluminum electrolytic capacitor or a 47µF solid tantalum capacitor between the output terminal and ground will guarantee stable operation.

If a bypass capacitor is connected between the output voltage adjust (ADJ) pin and ground, ripple rejection will be improved (please see the section entitled "RIPPLE REJECTION"). When ADJ pin bypassing is used, the required output capacitor value increases. Output capacitor values of 220µF (aluminum) or 47µF (tantalum) provide for all cases of bypassing the ADJ pin. If an ADJ pin bypass capacitor is not used, smaller output capacitor values are adequate. The table below shows recommended minimum capacitance values for stable operation.

#### RECOMMENDED CAPACITOR VALUES

| INPUT | OUTPUT                        | ADJ  |
|-------|-------------------------------|------|
| 10µF  | 15µF Tantalum, 100µF Aluminum | None |
| 10µF  | 47µF Tantalum, 220µF Aluminum | 15µF |

In order to ensure good transient response from the power supply system under rapidly changing current load conditions, designers generally use several output capacitors connected in parallel. Such an arrangement serves to minimize the effects of the parasitic resistance (ESR) and inductance (ESL) that are present in all capacitors. Cost-effective solutions that sufficiently limit ESR and ESL effects generally result in total capacitance values in the range of hundreds to thousands of microfarads, which is more than adequate to meet regulator output capacitor specifications. Output capacitance values may be increased without limit.

The circuit shown in Figure 1 can be used to observe the transient response characteristics of the regulator in a power system under changing loads. The effects of different capacitor types and values on transient response parameters, such as overshoot and undershoot, can be quickly compared in order to develop an optimum solution.

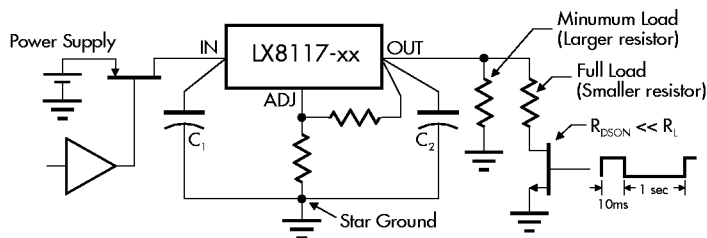

FIGURE 1 — DYNAMIC INPUT and OUTPUT TEST

#### OVERLOAD RECOVERY

Like almost all IC power regulators, the LX8117 regulators are equipped with Safe Operating Area (SOA) protection. The SOA circuit limits the regulator's maximum output current to progressively lower values as the input-to-output voltage difference increases. By limiting the maximum output current, the SOA circuit keeps the amount of power that is dissipated in the regulator itself within safe limits for all values of input-to-output voltage within the operating range of the regulator. The LX8117 SOA protection system is designed to be able to supply some output current for all values of input-to-output voltage, up to the device breakdown voltage.

Under some conditions, a correctly operating SOA circuit may prevent a power supply system from returning to regulated operation after removal of an intermittent short circuit at the output of the regulator. This is a normal mode of operation which can be seen in most similar products, including older devices such as 7800 series regulators. It is most likely to occur when the power system input voltage is relatively high and the load impedance is relatively low.

When the power system is started "cold", both the input and output voltages are very close to zero. The output voltage closely follows the rising input voltage, and the input-to-output voltage difference is small. The SOA circuit therefore permits the regulator to supply large amounts of current as needed to develop the designed voltage level at the regulator output. Now consider the case where the regulator is supplying regulated voltage to a resistive load under steady state conditions. A moderate input-to-output voltage appears across the regulator but the voltage difference is small enough that the SOA circuitry allows sufficient current to flow through the regulator to develop the designed output voltage across the load resistance. If the output resistor is short-circuited to ground, the input-to-output voltage difference across the regulator suddenly becomes larger by the amount of voltage that had appeared across the load resistor. The SOA circuit reads the increased input-to-output voltage, and cuts back the amount of current that it will permit the regulator to supply to its output terminal. When the short circuit across the output resistor is removed, all the regulator output current will again flow through the output resistor. The maximum current that the regulator can supply to the resistor will be limited by the SOA circuit, based on the large input-to-output voltage across the regulator at the time the short circuit is removed from the output.

# LX8117-xx/8117A-xx/8117B-xx

## 0.8, 1 & 1.2A LOW DROPOUT POSITIVE REGULATORS

### PRODUCTION DATA SHEET

#### APPLICATION NOTES

##### OVERLOAD RECOVERY (continued)

If this limited current is not sufficient to develop the designed voltage across the output resistor, the voltage will stabilize at some lower value, and will *never* reach the designed value. Under these circumstances, it may be necessary to cycle the input voltage down to zero in order to make the regulator output voltage return to regulation.

##### RIPPLE REJECTION

Ripple rejection can be improved by connecting a capacitor between the ADJ pin and ground. The value of the capacitor should be chosen so that the impedance of the capacitor is equal in magnitude to the resistance of R1 *at the ripple frequency*. The capacitor value can be determined by using this equation:

$$C = 1 / (6.28 * F_r * R1)$$

where: C ≡ the value of the capacitor in Farads;  
select an equal or larger standard value.

F<sub>r</sub> ≡ the ripple frequency in Hz  
R1 ≡ the value of resistor R1 in ohms

At a ripple frequency of 120Hz, with R1 = 100Ω:

$$C = 1 / (6.28 * 120\text{Hz} * 100\Omega) = 13.3\mu\text{F}$$

The closest equal or larger standard value should be used, in this case, 15μF.

When an ADJ pin bypass capacitor is used, output ripple amplitude will be essentially independent of the output voltage. If an ADJ pin bypass capacitor is not used, output ripple will be proportional to the ratio of the output voltage to the reference voltage:

$$M = V_{\text{OUT}} / V_{\text{REF}}$$

where: M ≡ a multiplier for the ripple seen when the ADJ pin is optimally bypassed.

$$V_{\text{REF}} = 1.25\text{V}$$

For example, if V<sub>OUT</sub> = 2.5V the output ripple will be:

$$M = 2.5\text{V} / 1.25\text{V} = 2$$

Output ripple will be twice as bad as it would be if the ADJ pin were to be bypassed to ground with a properly selected capacitor.

##### OUTPUT VOLTAGE

The LX8117 ICs develop a 1.25V reference voltage between the output and the adjust terminal (See Figure 2). By placing a resistor, R1, between these two terminals, a constant current is caused to flow through R1 and down through R2 to set the overall output voltage. Normally this current is the specified minimum load current of 10mA. Because I<sub>ADJ</sub> is very small and constant when compared with the current through R1, it represents a small error and can usually be ignored.

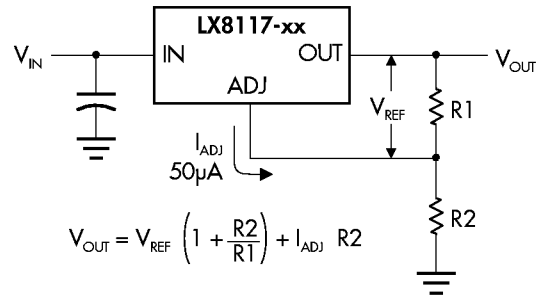

FIGURE 2 — BASIC ADJUSTABLE REGULATOR

##### LOAD REGULATION

Because the LX8117 regulators are three-terminal devices, it is not possible to provide true remote load sensing. Load regulation will be limited by the resistance of the wire connecting the regulator to the load. The data sheet specification for load regulation is measured at the bottom of the package. Negative side sensing is a true Kelvin connection, with the bottom of the output divider returned to the negative side of the load. Although it may not be immediately obvious, best load regulation is obtained when the top of the resistor divider, (R1), is connected *directly* to the case of the regulator, *not to the load*. This is illustrated in Figure 3. If R1 were connected to the load, the effective resistance between the regulator and the load would be:

$$R_{\text{Peff}} = R_p * \left( \frac{R2+R1}{R1} \right)$$

where: R<sub>p</sub> ≡ Actual parasitic line resistance.

When the circuit is connected as shown in Figure 3, the parasitic resistance appears as its actual value, rather than the higher R<sub>Peff</sub>.

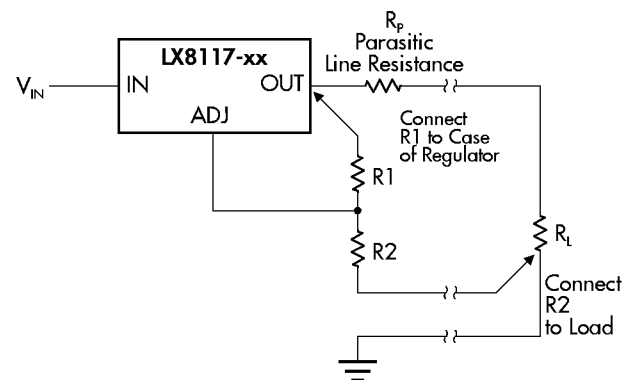

FIGURE 3 — CONNECTIONS FOR BEST LOAD REGULATION

# LX8117-xx/8117A-xx/8117B-xx

## 0.8, 1 & 1.2A LOW DROPOUT POSITIVE REGULATORS

### PRODUCTION DATA SHEET

#### APPLICATION NOTES

##### LOAD REGULATION (continued)

Even when the circuit is optimally configured, parasitic resistance can be a significant source of error. A 100 mil (2.54 mm) wide PC trace built from 1 oz. copper-clad circuit board material has a parasitic resistance of about 5 milliohms per inch of its length at room temperature. If a 3-terminal regulator used to supply 2.50 volts is connected by 2 inches of this trace to a load which draws 5 amps of current, a 50 millivolt drop will appear between the regulator and the load. Even when the regulator output voltage is precisely 2.50 volts, the load will only see 2.45 volts, which is a 2% error. It is important to keep the connection between the regulator output pin and the load as short as possible, and to use wide traces or heavy-gauge wire.

The minimum specified output capacitance for the regulator should be located near the regulator package. If several capacitors are used in parallel to construct the power system output capacitance, any capacitors beyond the minimum needed to meet the specified requirements of the regulator should be located near the sections of the load that require rapidly-changing amounts of current. Placing capacitors near the sources of load transients will help ensure that power system transient response is not impaired by the effects of trace impedance.

To maintain good load regulation, wide traces should be used on the input side of the regulator, especially between the input capacitors and the regulator. Input capacitor ESR must be small enough that the voltage at the input pin does not drop below  $V_{IN(MIN)}$  during transients.

$$V_{IN(MIN)} = V_{OUT} + V_{DROPOUT(MAX)}$$

- where:  $V_{IN(MIN)}$   $\equiv$  the lowest allowable instantaneous voltage at the input pin.  
 $V_{OUT}$   $\equiv$  the designed output voltage for the power supply system.  
 $V_{DROPOUT(MAX)}$   $\equiv$  the specified dropout voltage for the installed regulator.

##### THERMAL CONSIDERATIONS

The LX8117 regulators have internal power and thermal limiting circuitry designed to protect each device under overload conditions. For continuous normal load conditions, however, maximum junction temperature ratings must not be exceeded. It is important to give careful consideration to all sources of thermal resistance from junction to ambient. This includes junction to case, case to heat sink interface, and heat sink thermal resistance itself.

##### THERMAL CONSIDERATIONS (continued)

###### Example

Given:  $V_{IN} = 5.0V \pm 5\%$ ,  $V_{OUT} = 2.5V \pm 3\%$   
 $I_{OUT} = 0.5A$ ,  $T_A = 55^\circ C$ ,  $T_J = 125^\circ C$   
 $R_{\theta JT} = 15^\circ C/W$ ,  $R_{\theta TS} = 5^\circ C/W$

Find: The size of a square area of 1oz. copper circuit-board trace-foil that will serve as a heatsink, adequate to maintain the junction temperature of the LX8117 in the ST (SOT-223) package within specified limits.

Solution: The junction temperature is:

$$T_J = P_D (R_{\theta JT} + R_{\theta CS} + R_{\theta SA}) + T_A$$

where:  $P_D \equiv$  Dissipated power.

$R_{\theta JT} \equiv$  Thermal resistance from the junction to the mounting tab of the package.

$R_{\theta TS} \equiv$  Thermal resistance through the interface between the IC and the surface on which it is mounted.

$R_{\theta SA} \equiv$  Thermal resistance from the mounting surface of the heatsink to ambient.

$T_S \equiv$  Heat sink temperature.

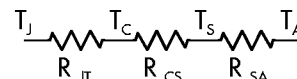

First, find the maximum allowable thermal resistance of the heat sink:

$$P_D = [(V_{IN} * (1 + Tol_{VIN})) - [V_{OUT} * (1 - Tol_{VOUT})]] * I_{OUT}$$

$$P_D = 1.4W$$

$$R_{\theta SA} = \frac{T_J - T_A}{P_D} - (R_{\theta JT} + R_{\theta TS}), \quad R_{\theta SA} = 29.6^\circ C/W$$

A test was conducted to determine the thermal characteristics of 1 oz. copper circuit-board trace material. The following equation describes the observed relationship between the area of a square copper pad, and the thermal resistance from the tab of a SOT-223 package soldered at the center of the pad to ambient.

$$Area_{SINK} = \frac{3.1^\circ C/W}{R_{\theta SA} - 22.3^\circ C/W} \text{ in}^2$$

Substituting the value for  $R_{\theta SA}$  calculated above, we find that a square pad with area:

$$Area_{SINK} = 0.43 \text{ in}^2 (0.66" \times 0.66"), 280\text{mm}^2 (17 \times 17 \text{ mm})$$

will be required to maintain the LX8117 junction temperature within specified limits.



# LX8117-xx/8117A-xx/8117B-xx

## 0.8, 1 & 1.2A LOW DROPOUT POSITIVE REGULATORS

### PRODUCTION DATA SHEET

#### TYPICAL APPLICATIONS

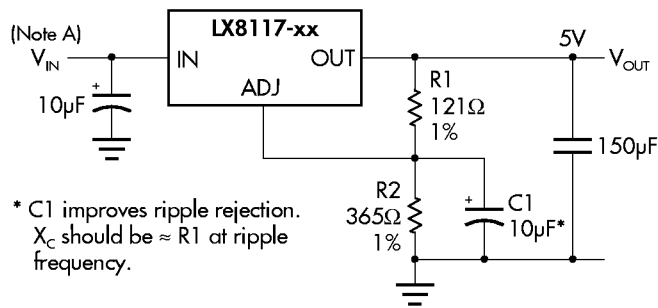

FIGURE 4 — IMPROVING RIPPLE REJECTION

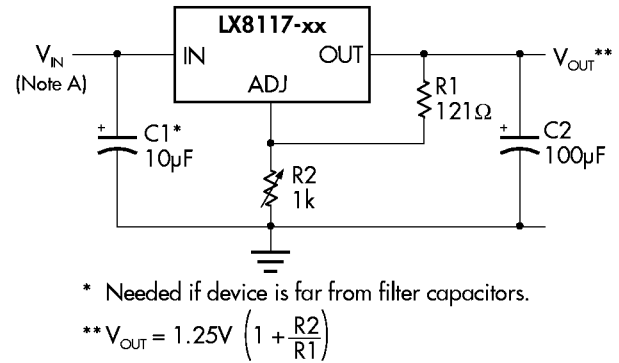

FIGURE 5 — 1.2V - 8V ADJUSTABLE REGULATOR

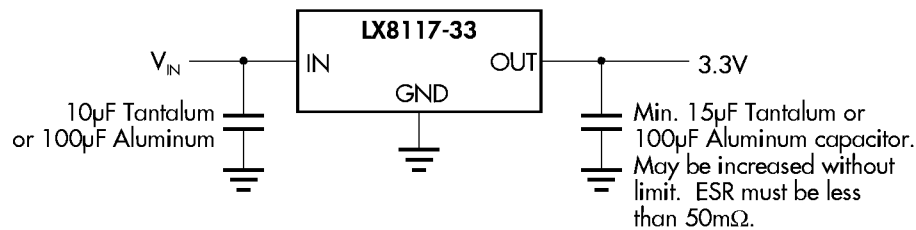

FIGURE 6 — FIXED 3.3V OUTPUT REGULATOR

Note A:  $V_{IN(MIN)} = (Intended V_{OUT}) + (V_{DROPOUT(MAX)})$

PRODUCTION DATA - Information contained in this document is proprietary to Linfinty, and is current as of publication date. This document may not be modified in any way without the express written consent of Linfinty. Product processing does not necessarily include testing of all parameters. Linfinty reserves the right to change the configuration and performance of the product and to discontinue product at any time.