

November 1994

CMOS NOR Gate

Features

- High-Voltage Types (20V Rating)
- Propagation Delay Time = 60ns (typ.) at $CL = 50pF$, $VDD = 10V$
- Buffered Inputs and Outputs
- Standard Symmetrical Output Characteristics
- 100% Tested for Maximum Quiescent Current at 20V
- 5V, 10V and 15V Parametric Ratings
- Maximum Input Current of $1\mu A$ at 18V Over Full Package-Temperature Range; 100nA at 18V and $+25^{\circ}C$
- Noise Margin (Over Full Package Temperature Range):
 - 1V at $VDD = 5V$
 - 2V at $VDD = 10V$
 - 2.5V at $VDD = 15V$
- Meets All Requirements of JEDEC Tentative Standards No. 13B, "Standard Specifications for Description of "B" Series CMOS Device's

Description

- CD4000BMS - Dual 3 Plus Inverter
- CD4001BMS - Quad 2 Input
- CD4002BMS - Dual 4 Input
- CD4025BMS - Triple 3 Input

CD4000BMS, CD4001BMS, CD4002BMS, and CD4025BMS NOR gates provide the system designer with direct implementation of the NOR function and supplement the existing family of CMOS gates. All inputs and outputs are buffered.

The CD4000BMS, CD4001BMS, CD4002BMS and the CD4025BMS is supplied in these 14 lead outline packages:

	CD4000B	CD4001B	CD4002B	CD4025B
Braze Seal DIP	H4X	H4Q	H4Q	H4Q
Frit Seal DIP	H1B	H1B	H1B	H1B
Ceramic Flatpack	H3W	H3W	H3W	H3W

Pinouts

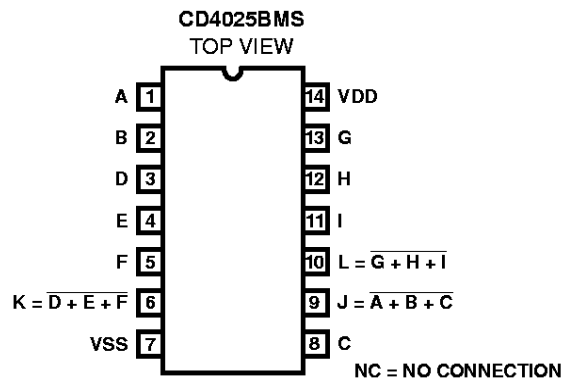
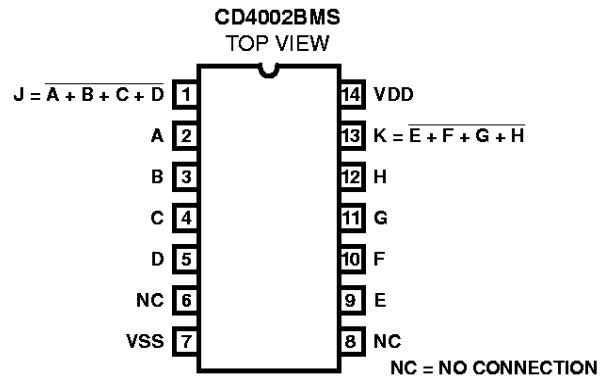
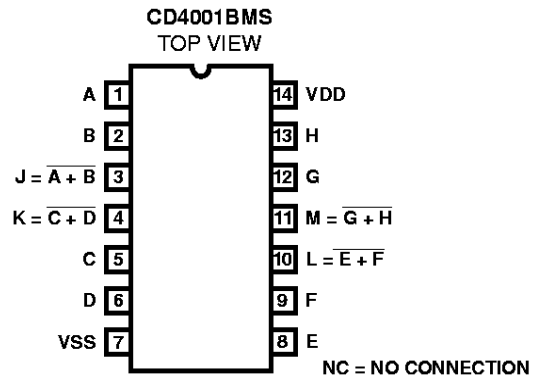
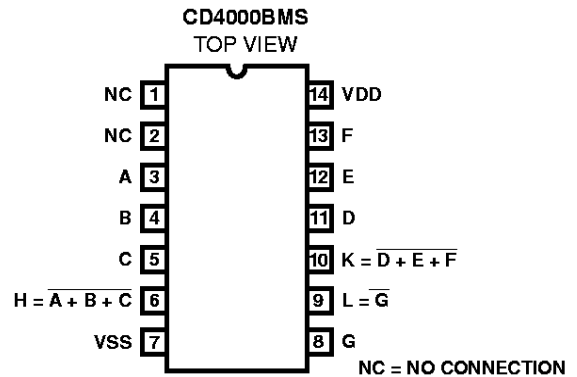

Functional Diagrams

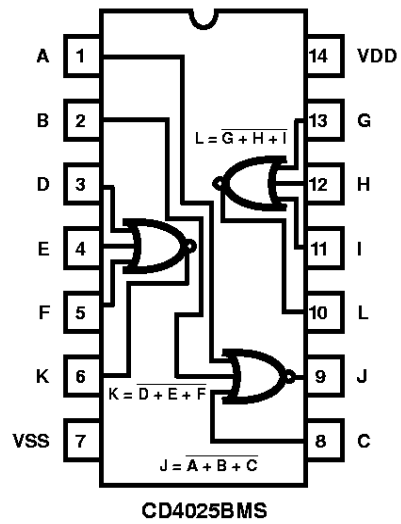
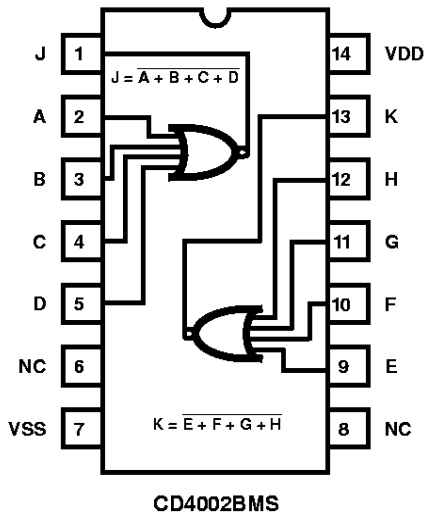
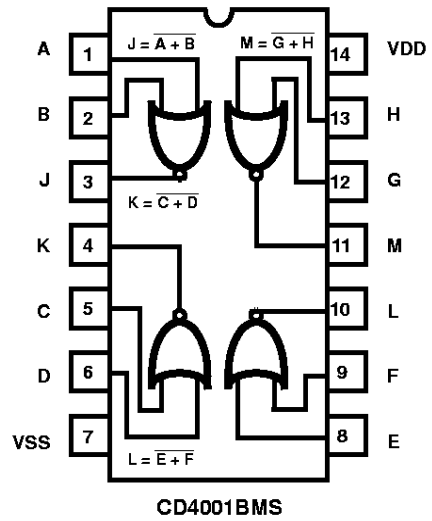
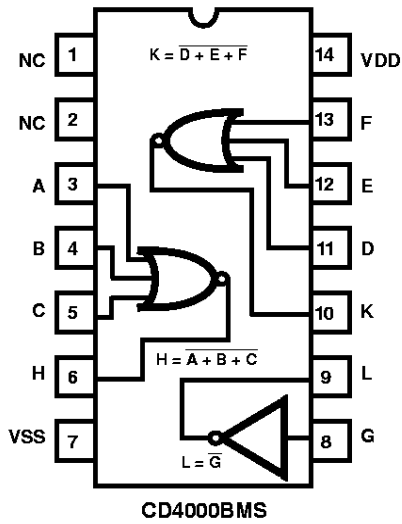

Specifications CD400BMS, CD4001BMS, CD4002BMS, CD4025BMS

Absolute Maximum Ratings

DC Supply Voltage Range, (VDD)	-0.5V to +20V (Voltage Referenced to VSS Terminals)
Input Voltage Range, All Inputs	-0.5V to VDD +0.5V
DC Input Current, Any One Input	±10mA
Operating Temperature Range	-55°C to +125°C Package Types D, F, K, H
Storage Temperature Range (TSTG)	-65°C to +150°C
Lead Temperature (During Soldering)	+265°C At Distance 1/16 ± 1/32 Inch (1.59mm ± 0.79mm) from case for 10s Maximum

Reliability Information

Thermal Resistance	θ_{ja}	θ_{jc}
Ceramic DIP and FRIT Package	80°C/W	20°C/W
Flatpack Package	70°C/W	20°C/W
Maximum Package Power Dissipation (PD) at +125°C		
For TA = -55°C to +100°C (Package Type D, F, K)	500mW	
For TA = +100°C to +125°C (Package Type D, F, K)	Derate Linearity at 12mW/°C to 200mW	
Device Dissipation per Output Transistor	100mW	
For TA = Full Package Temperature Range (All Package Types)		
Junction Temperature	+175°C	

TABLE 1. DC ELECTRICAL PERFORMANCE CHARACTERISTICS

PARAMETER	SYMBOL	CONDITIONS (NOTE 1)		GROUP A SUBGROUPS	TEMPERATURE	LIMITS		UNITS
						MIN	MAX	
Supply Current	IDD	VDD = 20V, VIN = VDD or GND		1	+25°C	-	0.5	µA
				2	+125°C	-	50	µA
		3	-55°C	-	0.5	µA		
Input Leakage	IIL	VIN = VDD or GND	VDD = 20	1	+25°C	-100	-	nA
				2	+125°C	-1000	-	nA
				3	-55°C	-100	-	nA
Input Leakage	IIH	VIN = VDD or GND	VDD = 20	1	+25°C	-	100	nA
				2	+125°C	-	1000	nA
				3	-55°C	-	100	nA
Output Voltage	VOL15	VDD = 15V, No Load		1, 2, 3	+25°C, +125°C, -55°C	-	50	mV
Output Voltage	VOH15	VDD = 15V, No Load (Note 3)		1, 2, 3	+25°C, +125°C, -55°C	14.95	-	V
Output Current (Sink)	IOL5	VDD = 5V, VOUT = 0.4V		1	+25°C	0.53	-	mA
Output Current (Sink)	IOL10	VDD = 10V, VOUT = 0.5V		1	+25°C	1.4	-	mA
Output Current (Sink)	IOL15	VDD = 15V, VOUT = 1.5V		1	+25°C	3.5	-	mA
Output Current (Source)	IOH5A	VDD = 5V, VOUT = 4.6V		1	+25°C	-	-0.53	mA
Output Current (Source)	IOH5B	VDD = 5V, VOUT = 2.5V		1	+25°C	-	-1.8	mA
Output Current (Source)	IOH10	VDD = 10V, VOUT = 9.5V		1	+25°C	-	-1.4	mA
Output Current (Source)	IOH15	VDD = 15V, VOUT = 13.5V		1	+25°C	-	-3.5	mA
N Threshold Voltage	VNTH	VDD = 10V, ISS = -10µA		1	+25°C	-2.8	-0.7	V
P Threshold Voltage	VPTH	VSS = 0V, IDD = 10µA		1	+25°C	0.7	2.8	V
Functional	F	VDD = 2.8V, VIN = VDD or GND		7	+25°C	VOH > VDD/2	VOL < VDD/2	V
		VDD = 20V, VIN = VDD or GND		7	+25°C			
		VDD = 18V, VIN = VDD or GND		8A	+125°C			
		VDD = 3V, VIN = VDD or GND		8B	-55°C			
Input Voltage Low (Note 2)	VIL	VDD = 5V, VOH > 4.5V, VOL < 0.5V		1, 2, 3	+25°C, +125°C, -55°C	-	1.5	V
Input Voltage High (Note 2)	VIH	VDD = 5V, VOH > 4.5V, VOL < 0.5V		1, 2, 3	+25°C, +125°C, -55°C	3.5	-	V
Input Voltage Low (Note 2)	VIL	VDD = 15V, VOH > 13.5V, VOL < 1.5V		1, 2, 3	+25°C, +125°C, -55°C	-	4	V
Input Voltage High (Note 2)	VIH	VDD = 15V, VOH > 13.5V, VOL < 1.5V		1, 2, 3	+25°C, +125°C, -55°C	11	-	V

NOTES: 1. All voltages referenced to device GND, 100% testing being implemented.
 2. Go/No Go test with limits applied to inputs
 3. For accuracy, voltage is measured differentially to VDD. Limit is 0.050V max.

Specifications CD400BMS, CD4001BMS, CD4002BMS, CD4025BMS

TABLE 2. AC ELECTRICAL PERFORMANCE CHARACTERISTICS

PARAMETER	SYMBOL	CONDITIONS (NOTE 1, 2)	GROUP A SUBGROUPS	TEMPERATURE	LIMITS		UNITS
					MIN	MAX	
Propagation Delay	TPHL TPLH	VDD = 5V, VIN = VDD or GND	9	+25°C	-	250	ns
			10, 11	+125°C, -55°C	-	338	ns
Transition Time	TTHL TTLH	VDD = 5V, VIN = VDD or GND	9	+25°C	-	200	ns
			10, 11	+125°C, -55°C	-	270	ns

NOTES:

1. CL = 50pF, RL = 200K, Input TR, TF < 20ns.
2. -55°C and +125°C limits guaranteed, 100% testing being implemented.

TABLE 3. ELECTRICAL PERFORMANCE CHARACTERISTICS

PARAMETER	SYMBOL	CONDITIONS	NOTES	TEMPERATURE	LIMITS		UNITS
					MIN	MAX	
Supply Current	IDD	VDD = 5V, VIN = VDD or GND	1, 2	-55°C, +25°C	-	0.25	μA
				+125°C	-	7.5	μA
		VDD = 10V, VIN = VDD or GND	1, 2	-55°C, +25°C	-	0.5	μA
				+125°C	-	1.5	μA
		VDD = 15V, VIN = VDD or GND	1, 2	-55°C, +25°C	-	0.5	μA
				+125°C	-	3.0	μA
Output Voltage	VOL	VDD = 5V, No Load	1, 2	+25°C, +125°C, -55°C	-	50	mV
Output Voltage	VOL	VDD = 10V, No Load	1, 2	+25°C, +125°C, -55°C	-	50	mV
Output Voltage	VOH	VDD = 5V, No Load	1, 2	+25°C, +125°C, -55°C	4.95	-	V
Output Voltage	VOH	VDD = 10V, No Load	1, 2	+25°C, +125°C, -55°C	9.95	-	V
Output Current (Sink)	IOL5	VDD = 5V, VOUT = 0.4V	1, 2	+125°C	0.36	-	mA
				-55°C	0.64	-	mA
Output Current (Sink)	IOL10	VDD = 10V, VOUT = 0.5V	1, 2	+125°C	0.9	-	mA
				-55°C	1.6	-	mA
Output Current (Sink)	IOL15	VDD = 15V, VOUT = 1.5V	1, 2	+125°C	2.4	-	mA
				-55°C	4.2	-	mA
Output Current (Source)	IOH5A	VDD = 5V, VOUT = 4.6V	1, 2	+125°C	-	-0.36	mA
				-55°C	-	-0.64	mA
Output Current (Source)	IOH5B	VDD = 5V, VOUT = 2.5V	1, 2	+125°C	-	-1.15	mA
				-55°C	-	-2.0	mA
Output Current (Source)	IOH10	VDD = 10V, VOUT = 9.5V	1, 2	+125°C	-	-0.9	mA
				-55°C	-	-1.6	mA
Output Current (Source)	IOH15	VDD = 15V, VOUT = 13.5V	1, 2	+125°C	-	-2.4	mA
				-55°C	-	-4.2	mA
Input Voltage Low	VIL	VDD = 10V, VOH > 9V, VOL < 1V	1, 2	+25°C, +125°C, -55°C	-	3	V
Input Voltage High	VIH	VDD = 10V, VOH > 9V, VOL < 1V	1, 2	+25°C, +125°C, -55°C	7	-	V
Propagation Delay	TPHL TPLH	VDD = 10V	1, 2, 3	+25°C	-	120	ns
		VDD = 15V	1, 2, 3	+25°C	-	90	ns
Transition Time	TTHL TTLH	VDD = 10V	1, 2, 3	+25°C	-	100	ns
		VDD = 15V	1, 2, 3	+25°C	-	80	ns

Specifications CD400BMS, CD4001BMS, CD4002BMS, CD4025BMS

TABLE 3. ELECTRICAL PERFORMANCE CHARACTERISTICS (Continued)

PARAMETER	SYMBOL	CONDITIONS	NOTES	TEMPERATURE	LIMITS		UNITS
					MIN	MAX	
Input Capacitance	CIN	Any Input	1, 2	+25°C	-	7.5	pF

NOTES:

1. All voltages referenced to device GND.
2. The parameters listed on Table 3 are controlled via design or process and are not directly tested. These parameters are characterized on initial design release and upon design changes which would affect these characteristics.
3. CL = 50pF, RL = 200K, Input TR, TF < 20ns.

TABLE 4. POST IRRADIATION ELECTRICAL PERFORMANCE CHARACTERISTICS

PARAMETER	SYMBOL	CONDITIONS	NOTES	TEMPERATURE	LIMITS		UNITS
					MIN	MAX	
Supply Current	IDD	VDD = 20V, VIN = VDD or GND	1, 4	+25°C	-	2.5	μA
N Threshold Voltage	VNTH	VDD = 10V, ISS = -10μA	1, 4	+25°C	-2.8	-0.2	V
N Threshold Voltage Delta	ΔVNTH	VDD = 10V, ISS = -10μA	1, 4	+25°C	-	±1	V
P Threshold Voltage	VPTH	VSS = 0V, IDD = 10μA	1, 4	+25°C	0.2	2.8	V
P Threshold Voltage Delta	ΔVPTH	VSS = 0V, IDD = 10μA	1, 4	+25°C	-	±1	V
Functional	F	VDD = 18V, VIN = VDD or GND VDD = 3V, VIN = VDD or GND	1	+25°C	VOH > VDD/2	VOL < VDD/2	V
Propagation Delay Time	TPHL TPLH	VDD = 5V	1, 2, 3, 4	+25°C	-	1.35 x +25°C Limit	ns

- NOTES: 1. All voltages referenced to device GND. 2. CL = 50pF, RL = 200K, Input TR, TF < 20ns. 3. See Table 2 for +25°C limit. 4. Read and Record

TABLE 5. BURN-IN AND LIFE TEST DELTA PARAMETERS +25°C

PARAMETER	SYMBOL	DELTA LIMIT
Supply Current - SSI	IDD	±0.1μA
Output Current (Sink)	IOL5	± 20% x Pre-Test Reading
Output Current (Source)	IOH5A	± 20% x Pre-Test Reading

TABLE 6. APPLICABLE SUBGROUPS

CONFORMANCE GROUP		MIL-STD-883 METHOD	GROUP A SUBGROUPS	READ AND RECORD
Initial Test (Pre Burn-In)		100% 5004	1, 7, 9	IDD, IOL5
Interim Test 1 (Post Burn-In)		100% 5004	1, 7, 9	IDD, IOL5
Interim Test 2 (Post Burn-In)		100% 5004	1, 7, 9	IDD, IOL5
PDA (Note 1)		100% 5004	1, 7, 9, Deltas	
Interim Test 3 (Post Burn-In)		100% 5004	1, 7, 9	IDD, IOL5, IOH5A
PDA (Note 1)		100% 5004	1, 7, 9, Deltas	
Final Test		100% 5004	2, 3, 8A, 8B, 10, 11	
Group A		Sample 5005	1, 2, 3, 7, 8A, 8B, 9, 10, 11	
Group B	Subgroup B-5	Sample 5005	1, 2, 3, 7, 8A, 8B, 9, 10, 11, Deltas	Subgroups 1, 2, 3, 9, 10, 11
	Subgroup B-6	Sample 5005	1, 7, 9	
Group D		Sample 5005	1, 2, 3, 8A, 8B, 9	Subgroups 1, 2, 3

NOTE: 1. 5% Parametric, 3% Functional; Cumulative for Static 1 and 2.

Specifications CD400BMS, CD4001BMS, CD4002BMS, CD4025BMS

TABLE 7. TOTAL DOSE IRRADIATION

CONFORMANCE GROUPS	MIL-STD-883 METHOD	TEST		READ AND RECORD	
		PRE-IRRAD	POST-IRRAD	PRE-IRRAD	POST-IRRAD
Group E Subgroup 2	5005	1, 7, 9	Table 4	1, 9	Table 4

TABLE 8. BURN-IN AND IRRADIATION TEST CONNECTIONS

FUNCTION	OPEN	GROUND	VDD	9V ± -0.5V	OSCILLATOR	
					50kHz	25kHz
PART NUMBER CD4000BMS						
Static Burn-In 1 Note 1	1, 2, 6, 9, 10	3 - 5, 7, 8, 11 - 13	14			
Static Burn-In 2 Note 1	1, 2, 6, 9, 10	7	3 - 5, 8, 11 - 14			
Dynamic Burn-In Note 1	1, 2	7	14	6, 9, 10	3 - 5, 8, 11 - 13	
Irradiation Note 2	1, 2, 6, 9, 10	7	3 - 5, 8, 11 - 14			
PART NUMBER CD4001BMS						
Static Burn-In 1 Note 1	3, 4, 10, 11	1, 2, 5 - 9, 12, 13	14			
Static Burn-In 2 Note 1	3, 4, 10, 11	7	1, 2, 5, 6, 8, 9, 12 - 14			
Dynamic Burn-In Note 1	-	7	14	3, 4, 10, 11	1, 2, 5, 6, 8, 9, 12, 13	
Irradiation Note 2	3, 4, 10, 11	7	1, 2, 5, 6, 8, 9, 12 - 14			
PART NUMBER CD4002BMS						
Static Burn-In 1 Note 1	1, 6, 8, 13	2 - 5, 7, 9 - 12	14			
Static Burn-In 2 Note 1	1, 6, 8, 13	7	2 - 5, 9 - 12, 14			
Dynamic Burn-In Note 1	6, 8	7	14	1, 13	2 - 5, 9 - 12	
Irradiation Note 2	1, 6, 8, 13	7	2 - 5, 9 - 12, 14			
PART NUMBER CD4025BMS						
Static Burn-In 1 Note 1	6, 9, 10	1 - 5, 7, 8, 11 - 13	14			
Static Burn-In 2 Note 1	6, 9, 10	7	1 - 5, 8, 11 - 14			
Dynamic Burn-In Note 1	-	7	14	6, 9, 10	1 - 5, 8, 11 - 13	
Irradiation Note 2	6, 9, 10	7	1 - 5, 8, 11 - 14			

NOTE:

1. Each pin except VDD and GND will have a series resistor of $10K \pm 5\%$, $VDD = 18V \pm 0.5V$
2. Each pin except VDD and GND will have a series resistor of $47K \pm 5\%$; Group E, Subgroup 2, sample size is 4 dice/wafer, 0 failures, $VDD = 10V \pm 0.5V$

Schematic and Logic Diagrams

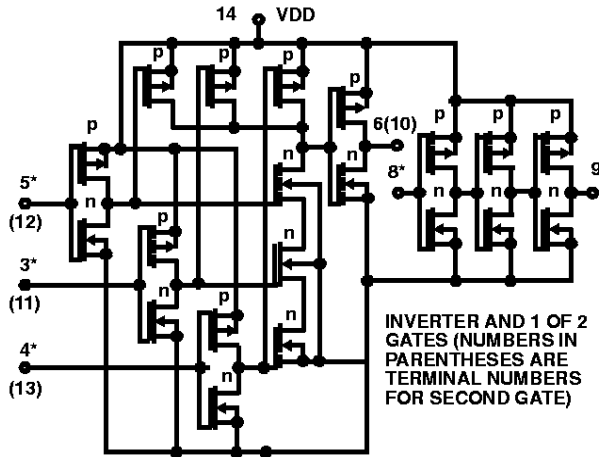

INVERTER AND 1 OF 2 GATES (NUMBERS IN PARENTHESES ARE TERMINAL NUMBERS FOR SECOND GATE)

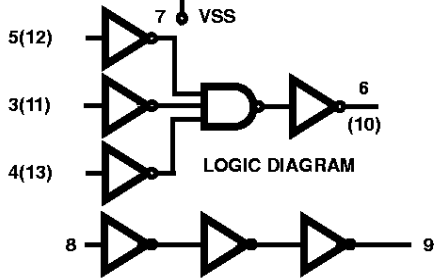

CD4000BMS

*ALL INPUTS ARE PROTECTED BY CMOS PROTECTION NETWORK

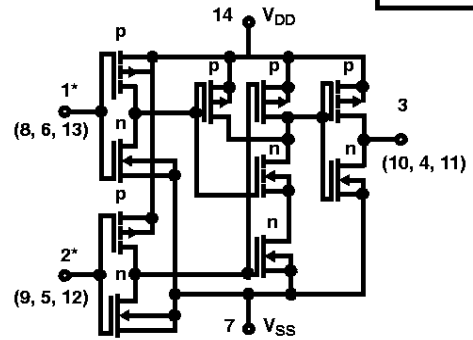
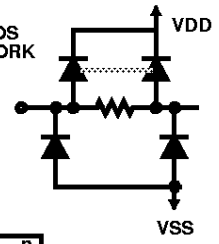

1 OF 4 GATES (NUMBERS IN PARANTHESES ARE TERMINAL NUMBERS FOR OTHER GATES)

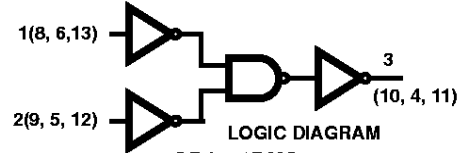

CD4001BMS

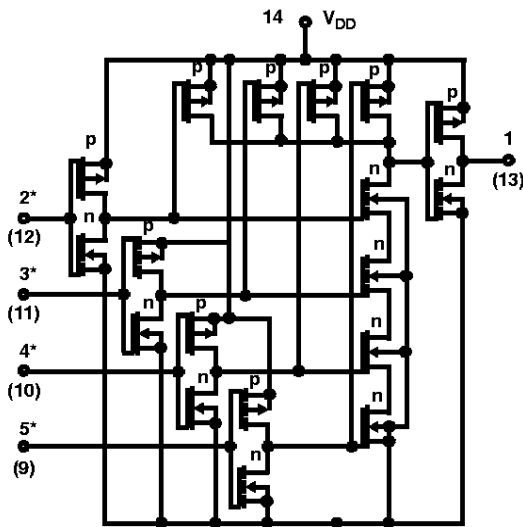

1 OF 2 GATES (NUMBERS IN PARENTHESES ARE TERMINAL NUMBERS FOR SECOND GATE)

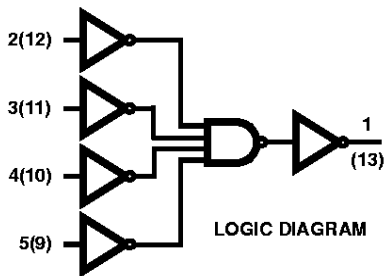

CD4002BMS

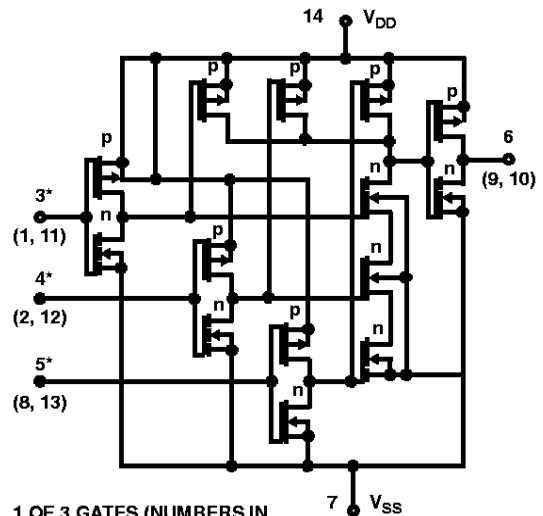

1 OF 3 GATES (NUMBERS IN PARENTHESES ARE TERMINAL NUMBERS FOR OTHER GATES)

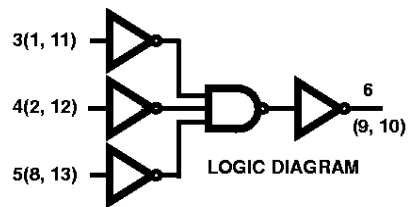

CD4025BMS

Typical Performance Characteristics

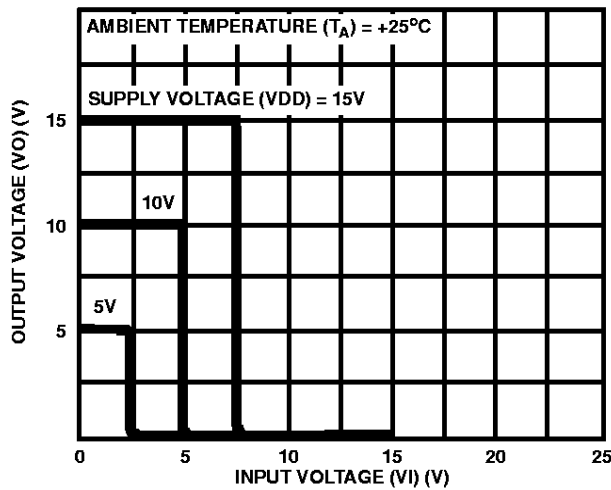

FIGURE 1. TYPICAL VOLTAGE TRANSFER CHARACTERISTICS

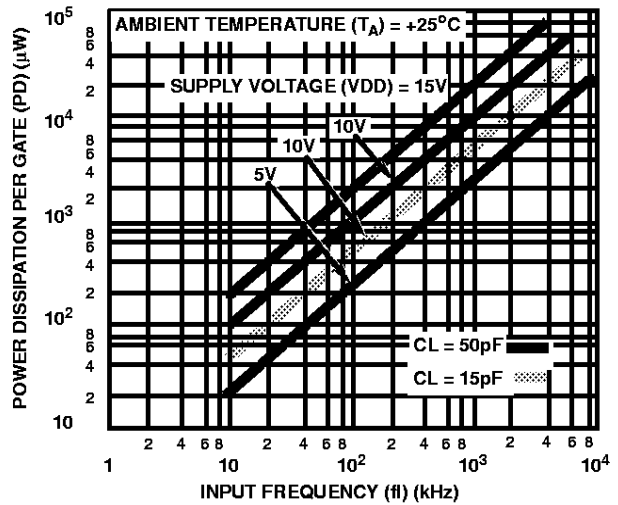

FIGURE 2. TYPICAL POWER DISSIPATION vs FREQUENCY

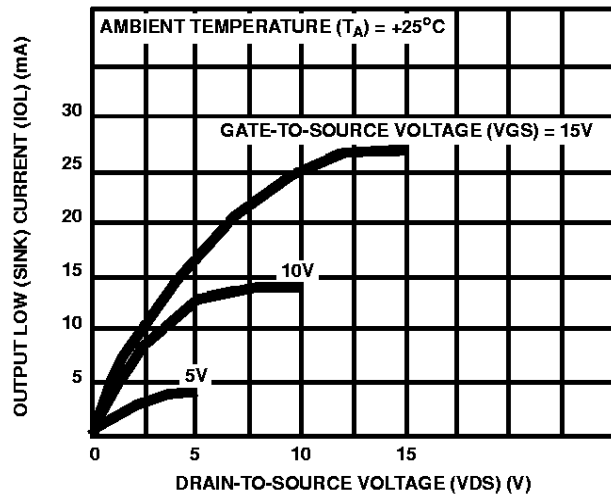

FIGURE 3. TYPICAL OUTPUT LOW (SINK) CURRENT CHARACTERISTICS

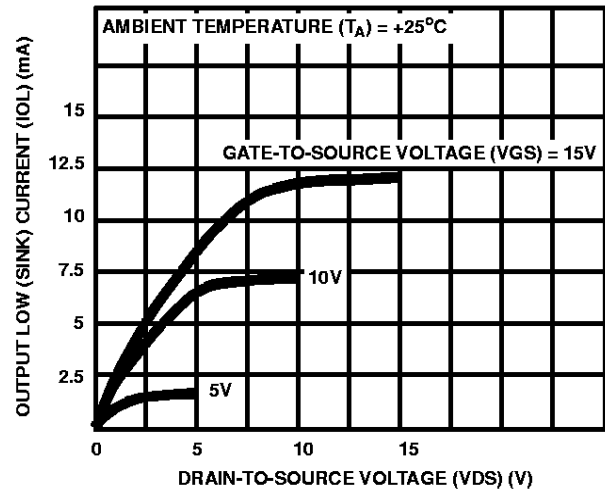

FIGURE 4. MINIMUM OUTPUT LOW (SINK) CURRENT CHARACTERISTICS

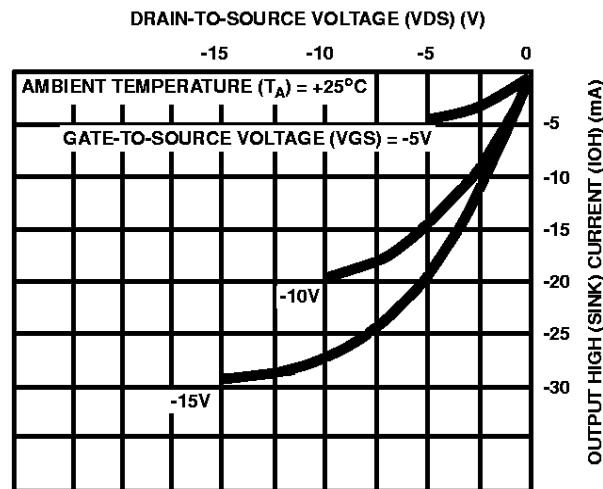

FIGURE 5. TYPICAL OUTPUT HIGH (SOURCE) CURRENT CHARACTERISTICS

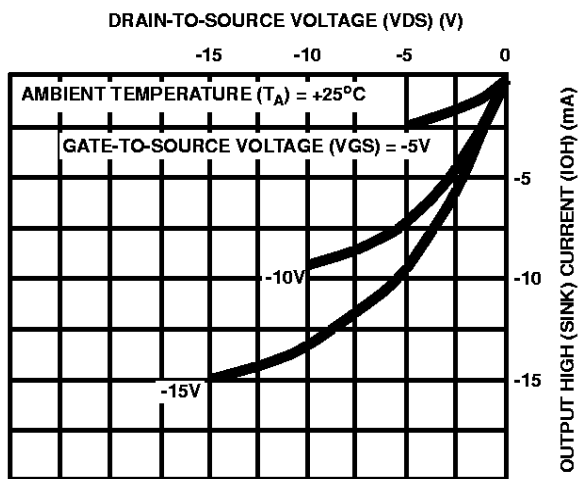

FIGURE 6. MINIMUM OUTPUT HIGH (SOURCE) CURRENT CHARACTERISTICS

Typical Performance Characteristics (Continued)

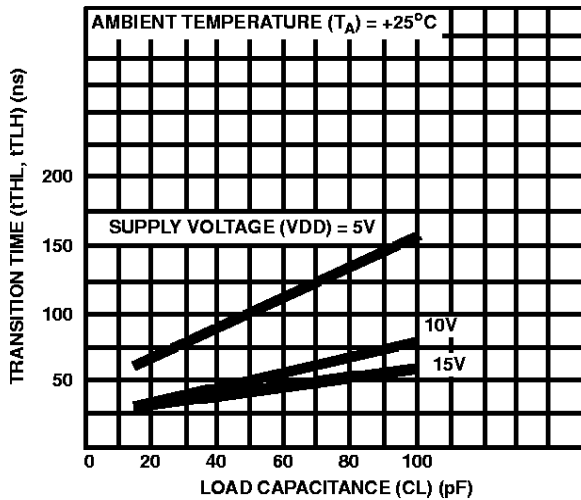

FIGURE 7. TYPICAL TRANSITION TIME vs LOAD CAPACITANCE

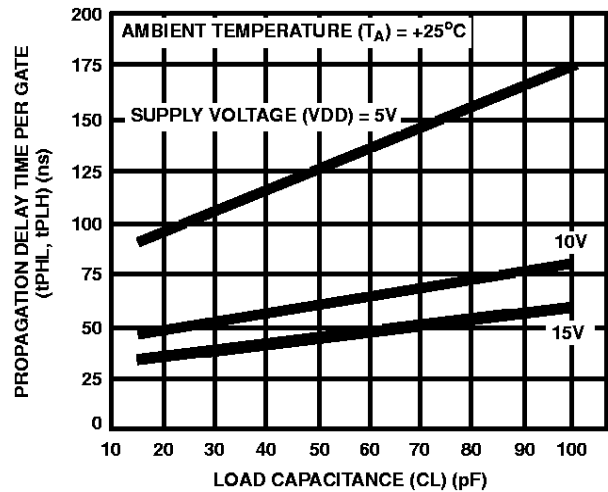
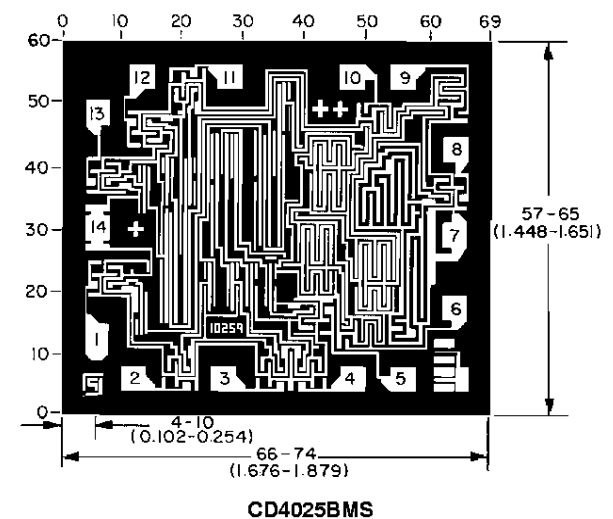
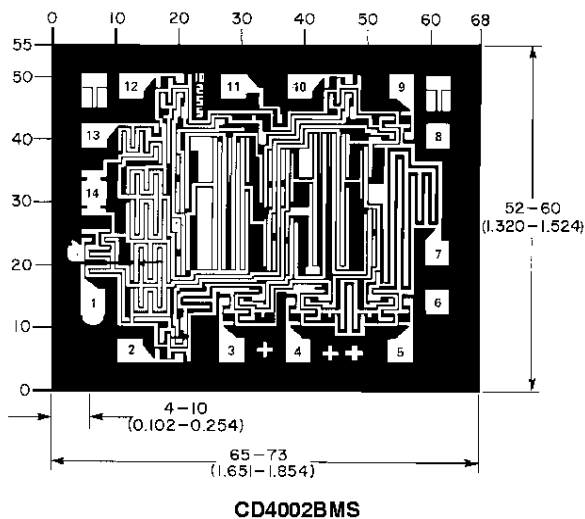
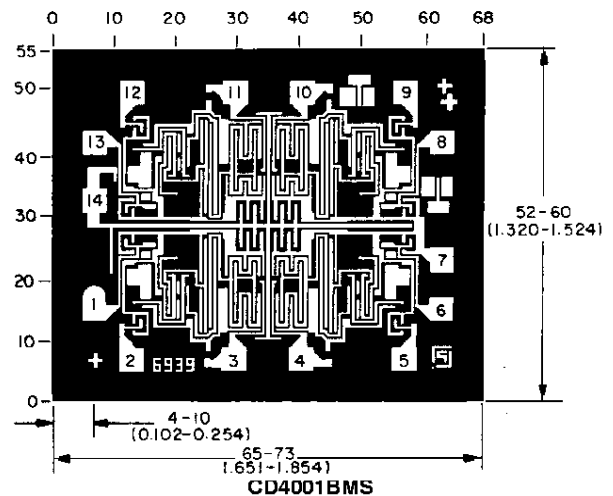
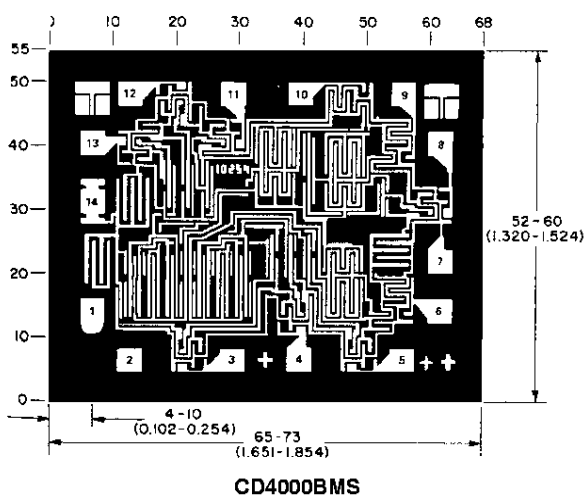

FIGURE 8. TYPICAL PROPAGATION DELAY TIME vs LOAD CAPACITANCE

Chip Dimensions and Pad Layouts



Dimensions in parentheses are in millimeters and are derived from the basic inch dimensions as indicated. Grid graduations are in mils (10^{-3} inch)