

SN54F240, SN74F240 OCTAL BUFFERS/DRIVERS WITH 3-STATE OUTPUTS

SDFS061A - D2932, MARCH 1987 - REVISED OCTOBER 1993

- 3-State Outputs Drive Bus Lines or Buffer Memory Address Registers
- Package Options Include Plastic Small-Outline (SOIC) and Shrink Small-Outline (SSOP) Packages, Ceramic Chip Carriers, and Plastic and Ceramic DIPs

description

These octal buffers and line drivers are designed specifically to improve both the performance and density of 3-state memory address drivers, clock drivers, and bus-oriented receivers and transmitters. Taken together with the 'F241 and 'F244, these devices provide the choice of selected combinations of inverting and noninverting outputs, symmetrical \overline{OE} (active-low output-enable) inputs, and complementary OE and \overline{OE} inputs.

The 'F240 is organized as two 4-bit buffers/line drivers with separate output enable (\overline{OE}) inputs. When \overline{OE} is low, the device passes data from the A inputs to the Y outputs. When \overline{OE} is high, the outputs are in the high-impedance state.

The SN74F240 is available in TI's shrink small-outline package (DB), which provides the same I/O pin count and functionality of standard small-outline packages in less than half the printed-circuit-board area.

The SN54F240 is characterized for operation over the full military temperature range of -55°C to 125°C . The SN74F240 is characterized for operation from 0°C to 70°C .

SN54F240 ... J PACKAGE
SN74F240 ... DB, DW, OR N PACKAGE
(TOP VIEW)

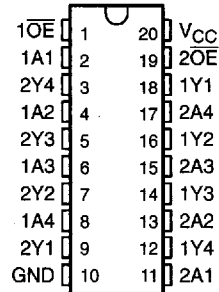

SN54F240 ... FK PACKAGE
(TOP VIEW)

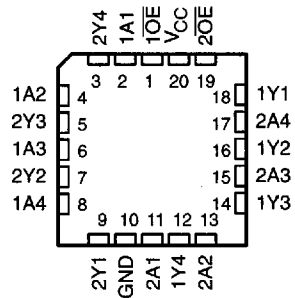

FUNCTION TABLE
(each buffer)

INPUTS		OUTPUT
\overline{OE}	A	Y
L	H	L
L	L	H
H	X	Z

SN54F240, SN74F240 OCTAL BUFFERS/DRIVERS WITH 3-STATE OUTPUTS

SDFS061A - D2932, MARCH 1987 - REVISED OCTOBER 1993

logic symbol†

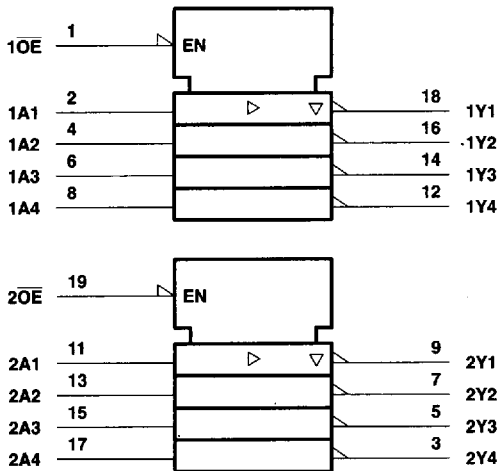

† This symbol is in accordance with ANSI/IEEE Std 91-1984 and IEC Publication 617-12.

logic diagram (positive logic)

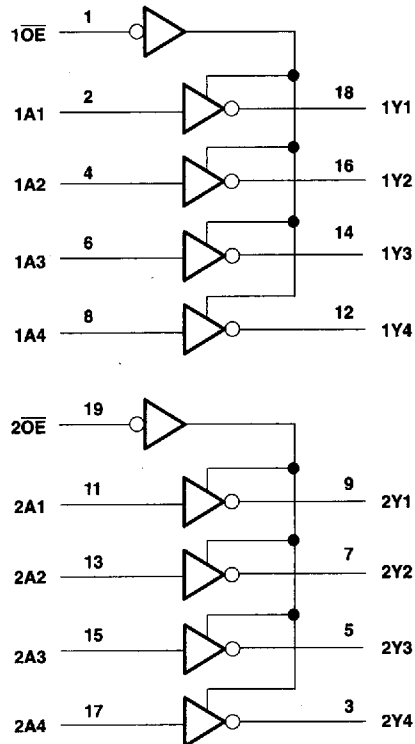

absolute maximum ratings over operating free-air temperature range (unless otherwise noted)‡

Supply voltage range, V_{CC}	-0.5 V to 7 V
Input voltage range, V_I (see Note 1)	-1.2 V to 7 V
Input current range	-30 mA to 5 mA
Voltage range applied to any output in the disabled or power-off state	-0.5 V to 5.5 V
Voltage range applied to any output in the high state	-0.5 V to V_{CC}
Current into any output in the low state: SN54F240	96 mA
SN74F240	128 mA
Operating free-air temperature range: SN54F240	-55°C to 125°C
SN74F240	0°C to 70°C
Storage temperature range	-65°C to 150°C

‡ Stresses beyond those listed under "absolute maximum ratings" may cause permanent damage to the device. These are stress ratings only and functional operation of the device at these or any other conditions beyond those indicated under "recommended operating conditions" is not implied. Exposure to absolute-maximum-rated conditions for extended periods may affect device reliability.

NOTE 1: The input voltage ratings may be exceeded provided the input current ratings are observed.

SN54F240, SN74F240 OCTAL BUFFERS/DRIVERS WITH 3-STATE OUTPUTS

SDFS061A - D2932, MARCH 1987 - REVISED OCTOBER 1993

recommended operating conditions

		SN54F240			SN74F240			UNIT
		MIN	NOM	MAX	MIN	NOM	MAX	
V _{CC}	Supply voltage	4.5	5	5.5	4.5	5	5.5	V
V _{IH}	High-level input voltage	2			2			V
V _{IL}	Low-level input voltage				0.8			V
I _{IK}	Input clamp current				-18			mA
I _{OH}	High-level output current				-12			mA
I _{OL}	Low-level output current				48			mA
T _A	Operating free-air temperature	-55		125	0		70	°C

electrical characteristics over recommended operating free-air temperature range (unless otherwise noted)

PARAMETER	TEST CONDITIONS		SN54F240			SN74F240			UNIT
			MIN	TYP†	MAX	MIN	TYP†	MAX	
V _{IK}	V _{CC} = 4.5 V,	I _I = -18 mA	-1.2			-1.2			V
V _{OH}	V _{CC} = 4.5 V	I _{OH} = -3 mA	2.4	3.3		2.4	3.3		V
		I _{OH} = -12 mA	2	3.2					
		I _{OH} = -15 mA				2	3.1		
	V _{CC} = 4.75 V,	I _{OH} = -3 mA				2.7			
V _{OL}	V _{CC} = 4.5 V	I _{OL} = 48 mA	0.38	0.55					V
		I _{OL} = 64 mA				0.42	0.55		
I _{OZH}	V _{CC} = 5.5 V,	V _O = 2.7 V	50			50			μA
I _{OZL}	V _{CC} = 5.5 V,	V _O = 0.5 V	-50			-50			μA
I _I	V _{CC} = 5.5 V,	V _I = 7 V	0.1			0.1			mA
I _{IH}	V _{CC} = 5.5 V,	V _I = 2.7 V	20			20			μA
I _{IL}	V _{CC} = 5.5 V,	V _I = 0.5 V	-1			-1			mA
I _{OS‡}	V _{CC} = 5.5 V,	V _O = 0	-100		-225	-100		-225	mA
I _{CC}	V _{CC} = 5.5 V	Outputs high	19	29		19	29		mA
		Outputs low	50	75		50	75		
		Outputs disabled	42	63		42	63		

† All typical values are at V_{CC} = 5 V, T_A = 25°C.

‡ Not more than one output should be shorted at a time, and the duration of the short circuit should not exceed one second.

8961723 0096449 953

 **TEXAS
INSTRUMENTS**

POST OFFICE BOX 655303 • DALLAS, TEXAS 75265

SN54F240, SN74F240
OCTAL BUFFERS/DRIVERS
WITH 3-STATE OUTPUTS

SDFS061A - D2932, MARCH 1987 - REVISED OCTOBER 1993

switching characteristics (see Note 2)

PARAMETER	FROM (INPUT)	TO (OUTPUT)	V _{CC} = 5 V, C _L = 50 pF, R _L = 500 Ω, T _A = 25°C			V _{CC} = 4.5 V to 5.5 V, C _L = 50 pF, R _L = 500 Ω, T _A = MIN to MAX†				UNIT
			'F240			SN54F240		SN74F240		
			MIN	TYP	MAX	MIN	MAX	MIN	MAX	
t _{PLH}	Any A	Y	2.2	4.7	7	2.2	9	2.2	8	ns
t _{PHL}			1.2	3.1	4.7	1.2	6	1.2	5.7	
t _{PZH}	OE	Y	1.2	3.1	5.3	1.2	6.7	1.2	6.1	ns
t _{PZL}			3.2	6.5	9	3.2	10.5	3.2	10	
t _{PHZ}	OE	Y	1.2	3.6	5.3	1.2	6.5	1.2	6.3	ns
t _{PLZ}			1.2	5.6	8	1.2	12.5	1.2	9.5	

† For conditions shown as MIN or MAX, use the appropriate value specified under recommended operating conditions.

NOTE 2: Load circuits and waveforms are shown in Section 1.