

CD54/74AC109, CD54/74AC112 CD54/74ACT109, CD54/74ACT112

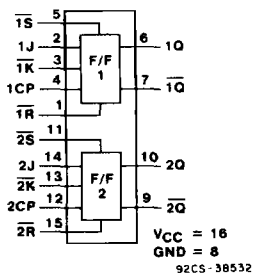

**CD54/74AC/ACT109
FUNCTIONAL DIAGRAM**

Dual "J-K" Flip-Flop with Set and Reset

CD54/74AC/ACT109 - Positive-Edge-Triggered (J, \bar{K})
CD54/74AC/ACT112 - Negative-Edge-Triggered (J, K)

Type Features:

- Buffered inputs
- Typical propagation delay:
4.8 ns @ $V_{CC} = 5\text{ V}$, $T_A = 25^\circ\text{C}$, $C_L = 50\text{ pF}$

The RCA CD54/74AC109 and CD54/74AC112 and the CD54/74ACT109 and CD54/74ACT112 dual "J-K" flip-flops with set and reset use the RCA ADVANCED CMOS technology. These flip-flops have independent J, K (or K), Set, Reset, and Clock inputs and Q and \bar{Q} outputs. The CD54/74AC/ACT112 changes state on the negative-going transition of the clock pulse. The CD54/74AC/ACT109 changes state on the positive-going transition of the clock. Set and Reset are accomplished asynchronously by low-level inputs.

The CD74AC/ACT109 and CD74AC/ACT112 are supplied in 16-lead dual-in-line plastic packages (E suffix) and in 16-lead dual-in-line small-outline plastic packages (M suffix). Both package types are operable over the following temperature ranges: Commercial (0 to 70°C); Industrial (-40 to +85°C); and Extended Industrial/Military (-55 to +125°C).

The CD54AC/ACT109 and CD54AC/ACT112, available in chip form (H suffix), are operable over the -55 to +125°C temperature range.

Family Features:

- Exceeds 2-kV ESD Protection - MIL-STD-883, Method 3015
- SCR-Latchup-resistant CMOS process and circuit design
- Speed of bipolar FAST*/AS/S with significantly reduced power consumption
- Balanced propagation delays
- AC types feature 1.5-V to 5.5-V operation and balanced noise immunity at 30% of the supply
- $\pm 24\text{-mA}$ output drive current
 - Fanout to 15 FAST* ICs
 - Drives 50-ohm transmission lines

*FAST is a Registered Trademark of Fairchild Semiconductor Corp.

CD54/74AC/ACT109 TRUTH TABLE

INPUTS					OUTPUTS	
\bar{S}	\bar{R}	CP	J	\bar{K}	Q	\bar{Q}
L	H	X	X	X	H	L
H	L	X	X	X	L	H
L	L	X	X	X	H*	H*
H	H		L	L	L	H
H	H		H	L	TOGGLE	
H	H		L	H	NO CHANGE	
H	H		H	H	H	L
H	H	L	X	X	NO CHANGE	

*Unpredictable and unstable condition if both \bar{S} and \bar{R} go high simultaneously.

CD54/74AC109, CD54/74AC112 CD54/74ACT109, CD54/74ACT112

CD54/74AC/ACT112 TRUTH TABLE

INPUTS					OUTPUTS	
\bar{S}	\bar{R}	\bar{CP}	J	K	Q	\bar{Q}
L	H	X	X	X	H	L
H	L	X	X	X	L	H
L	L	X	X	X	H*	H*
H	H		L	L	NO CHANGE	NO CHANGE
H	H		H	L	H	L
H	H		L	H	L	H
H	H		H	H	TOGGLE	TOGGLE
H	H	H	X	X	NO CHANGE	NO CHANGE

*Output states unpredictable if \bar{S} and \bar{R} go High simultaneously after both being Low at the same time.

H = High steady state

L = Low steady state

X = Irrelevant

= High-to-Low transition

= Low-to-High transition

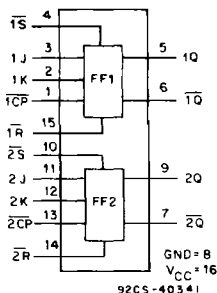

CD54/74AC/ACT112
FUNCTIONAL DIAGRAM

MAXIMUM RATINGS, Absolute-Maximum Values:

DC SUPPLY-VOLTAGE (V_{CC})	-0.5 to 6 V
DC INPUT DIODE CURRENT, I_{IK} (for $V_i < -0.5$ V or $V_i > V_{CC} + 0.5$ V)	± 20 mA
DC OUTPUT DIODE CURRENT, I_{OK} (for $V_o < -0.5$ V or $V_o > V_{CC} + 0.5$ V)	± 50 mA
DC OUTPUT SOURCE OR SINK CURRENT per Output Pin, I_o (for $V_o > -0.5$ V or $V_o < V_{CC} + 0.5$ V)	± 50 mA
DC V_{CC} or GROUND CURRENT (I_{CC} or I_{GND})	± 100 mA*
POWER DISSIPATION PER PACKAGE (P_D):	
For $T_A = -55$ to $+100^\circ\text{C}$ (PACKAGE TYPE E)	500 mW
For $T_A = +100$ to $+125^\circ\text{C}$ (PACKAGE TYPE E)	Derate Linearly at 8 mW/ $^\circ\text{C}$ to 300 mW
For $T_A = -55$ to $+70^\circ\text{C}$ (PACKAGE TYPE M)	400 mW
For $T_A = +70$ to $+125^\circ\text{C}$ (PACKAGE TYPE M)	Derate Linearly at 6 mW/ $^\circ\text{C}$ to 70 mW
OPERATING-TEMPERATURE RANGE (T_A)	-55 to $+125^\circ\text{C}$
STORAGE TEMPERATURE (T_{stg})	-65 to $+150^\circ\text{C}$
LEAD TEMPERATURE (DURING SOLDERING):	
At distance 1/16 \pm 1/32 in. (1.59 \pm 0.79 mm) from case for 10 s maximum	$+265^\circ\text{C}$
Unit inserted into PC board min. thickness 1/16 in. (1.59 mm) with solder contacting lead tips only	$+300^\circ\text{C}$

*For up to 4 outputs per device; add ± 25 mA for each additional output.

RECOMMENDED OPERATING CONDITIONS:

For maximum reliability, normal operating conditions should be selected so that operation is always within the following ranges:

CHARACTERISTICS	LIMITS		UNITS
	MIN.	MAX.	
Supply-Voltage Range, V_{CC} * (For $T_A =$ Full Package-Temperature Range) AC Types ACT Types	1.5 4.5	5.5 5.5	V V
DC Input or Output Voltage, V_i, V_o	0	V_{CC}	V
Operating Temperature, T_A	-55	+125	$^\circ\text{C}$
Input Rise and Fall Slew Rate, dt/dv at 1.5 V to 3 V (AC Types) at 3.6 V to 5.5 V (AC Types) at 4.5 V to 5.5 V (ACT Types)	0 0 0	50 20 10	ns/V ns/V ns/V

*Unless otherwise specified, all voltages are referenced to ground

CD54/74AC109, CD54/74AC112 CD54/74ACT109, CD54/74ACT112

STATIC ELECTRICAL CHARACTERISTICS: AC Series

CHARACTERISTICS	TEST CONDITIONS	V_{CC} (V)	AMBIENT TEMPERATURE (T_A) - °C						UNITS		
			+25		-40 to +85		-55 to +125				
			MIN.	MAX.	MIN.	MAX.	MIN.	MAX.			
High-Level Input Voltage V_{IH}			1.5	1.2	—	1.2	—	1.2	—	V	
			3	2.1	—	2.1	—	2.1	—		
			5.5	3.85	—	3.85	—	3.85	—		
Low-Level Input Voltage V_{IL}			1.5	—	0.3	—	0.3	—	0.3	V	
			3	—	0.9	—	0.9	—	0.9		
			5.5	—	1.65	—	1.65	—	1.65		
High-Level Output Voltage V_{OH}	V_{IH} or V_{IL}	#, *	-0.05	1.5	1.4	—	1.4	—	1.4	V	
			-0.05	3	2.9	—	2.9	—	2.9		
			-0.05	4.5	4.4	—	4.4	—	4.4		
			-4	3	2.58	—	2.48	—	2.4		
			-24	4.5	3.94	—	3.8	—	3.7		
			-75	5.5	—	—	3.85	—	—		
Low-Level Output Voltage V_{OL}	V_{IH} or V_{IL}	#, *	0.05	1.5	—	0.1	—	0.1	—	V	
			0.05	3	—	0.1	—	0.1	—		
			0.05	4.5	—	0.1	—	0.1	—		
			12	3	—	0.36	—	0.44	—		0.5
			24	4.5	—	0.36	—	0.44	—		0.5
			75	5.5	—	—	—	1.65	—		—
Input Leakage Current I_i	V_{CC} or GND		5.5	—	±0.1	—	±1	—	±1	μA	
Quiescent Supply Current, FF I_{CC}	V_{CC} or GND	0	5.5	—	4	—	40	—	80	μA	

#Test one output at a time for a 1-second maximum duration. Measurement is made by forcing current to and measuring voltage to minimize power dissipation.

* Test verifies a minimum 50-ohm transmission-line-drive capability at +85°C. 75 ohms at +125°C.

9

TERMINAL ASSIGNMENT DIAGRAMS

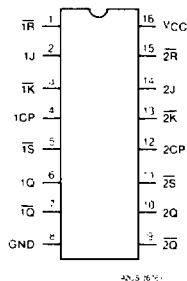

CD54/74AC/ACT109

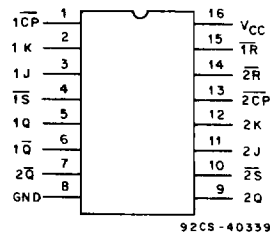

CD54/74AC/ACT112

CD54/74AC109, CD54/74AC112 CD54/74ACT109, CD54/74ACT112

STATIC ELECTRICAL CHARACTERISTICS: ACT Series

CHARACTERISTICS	TEST CONDITIONS		V _{CC} (V)	AMBIENT TEMPERATURE (T _A) - °C						UNITS	
				+25		-40 to +85		-55 to +125			
				MIN.	MAX.	MIN.	MAX.	MIN.	MAX.		
High-Level Input Voltage	V _{IH}		4.5 to 5.5	2	—	2	—	2	—	V	
Low-Level Input Voltage	V _{IL}		4.5 to 5.5	—	0.8	—	0.8	—	0.8	V	
High-Level Output Voltage	V _{OH}	V _{IH} or V _{IL} #, *	-0.05	4.5	4.4	—	4.4	—	4.4	—	V
			-24	4.5	3.94	—	3.8	—	3.7	—	
			-75	5.5	—	—	3.85	—	—	—	
			-50	5.5	—	—	—	—	3.85	—	
Low-Level Output Voltage	V _{OL}	V _{IH} or V _{IL} #, *	0.05	4.5	—	0.10	—	0.10	—	0.10	V
			24	4.5	—	0.36	—	0.44	—	0.50	
			75	5.5	—	—	—	1.65	—	—	
			50	5.5	—	—	—	—	—	1.65	
Input Leakage Current	I _I	V _{CC} or GND	5.5	—	±0.1	—	±1	—	±1	μA	
Quiescent Supply Current, FF	I _{CC}	V _{CC} or GND	0	5.5	—	4	—	40	—	80	μA
Additional Supply Current per Input Pin TTL Inputs High 1 Unit Load	ΔI _{CC}	V _{CC} -2.1	4.5 to 5.5	—	2.4	—	2.8	—	3	mA	

#Test one output at a time for a 1-second maximum duration. Measurement is made by forcing current and measuring voltage to minimize power dissipation.

*Test verifies a minimum 50-ohm transmission-line-drive capability at +85°C, 75 ohms at +125°C.

ACT INPUT LOADING TABLE

INPUT	UNIT LOADS*	
	109	112
J, CP, \overline{CP}	1	1
K	—	0.53
\overline{K}	0.53	—
\overline{S} , \overline{R}	0.58	0.58

*Unit load is ΔI_{CC} limit specified in Static Characteristics Chart, e.g., 2.4 mA max. @ 25°C.

CD54/74AC109, CD54/74AC112 CD54/74ACT109, CD54/74ACT112

PREREQUISITE FOR SWITCHING: AC Series

CHARACTERISTICS	SYMBOL	V _{CC} (V)	AMBIENT TEMPERATURE (T _A) - °C				UNITS
			-40 to +85		-55 to +125		
			MIN.	MAX.	MIN.	MAX.	
Maximum CP, (\overline{CP}) Frequency 109	f _{max}	1.5	9	—	8	—	MHz
		3.3*	81	—	71	—	
		5†	114	—	100	—	
112	f _{max}	1.5	9	—	8	—	MHz
		3.3	81	—	71	—	
		5	114	—	100	—	
CP, (\overline{CP}) Pulse Width	t _w	1.5	55	—	63	—	ns
		3.3	6	—	7	—	
		5	4.4	—	5	—	
R, \overline{S} Pulse Width	t _w	1.5	49	—	56	—	ns
		3.3	5.5	—	6.3	—	
		5	3.9	—	4.5	—	
Setup Time J, K to CP 109	t _{su}	1.5	61	—	69	—	ns
		3.3	6.8	—	7.7	—	
		5	4.8	—	5.5	—	
J, K to \overline{CP} 112	t _{su}	1.5	44	—	50	—	ns
		3.3	4.9	—	5.6	—	
		5	3.5	—	4	—	
Hold Time J, K to CP 109	t _h	1.5	0	—	0	—	ns
		3.3	0	—	0	—	
		5	0	—	0	—	
J, K to \overline{CP} 112	t _h	1.5	0	—	0	—	ns
		3.3	0	—	0	—	
		5	0	—	0	—	
Removal Time R, S to CP, (\overline{CP})	t _{rem}	1.5	27	—	31	—	ns
		3.1	3.1	—	3.5	—	
		5	2.2	—	2.5	—	

*3.3 V: min. is @ 3 V
†5 V: min is @ 4.5 V

SWITCHING CHARACTERISTICS: AC Series; t_r, t_f = 3 ns, C_L = 50 pF

CHARACTERISTICS	SYMBOL	V _{CC} (V)	AMBIENT TEMPERATURE (T _A) - °C				UNITS
			-40 to +85		-55 to +125		
			MIN.	MAX.	MIN.	MAX.	
Propagation Delays: CP, (\overline{CP}) to Q, \overline{Q}	t _{PLH} t _{PHL}	1.5	—	117	—	129	ns
		3.3*	3.7	13.1	3.6	14.4	
		5†	2.7	9.4	2.6	10.3	
\overline{S} , R to Q, \overline{Q}	t _{PLH} t _{PHL}	1.5	—	139	—	153	ns
		3.3	4.4	15.5	4.3	17.1	
		5	3.2	11.1	3.1	12.2	
Power Dissipation Capacitance	C _{PD} §	—	56 Typ.		56 Typ.		pF
Input Capacitance	C _I	—	—	10	—	10	pF

*3.3 V: min. is @ 3.6 V
max. is @ 3 V
†5 V: min. is @ 5.5 V
max. is @ 4.5 V

§C_{PD} is used to determine the dynamic power consumption, per flip-flop.

$$P_D = C_{PD}V_{CC}^2 f_i + \sum (C_L V_{CC}^2 f_o)$$

where f_i = input frequency
f_o = output frequency
C_L = output load capacitance
V_{CC} = supply voltage.

CD54/74AC109, CD54/74AC112 CD54/74ACT109, CD54/74ACT112

PREREQUISITE FOR SWITCHING: ACT Series

CHARACTERISTICS	SYMBOL	V _{CC} (V)	AMBIENT TEMPERATURE (T _A) - °C				UNITS
			-40 to +85		-55 to +125		
			MIN.	MAX.	MIN.	MAX.	
Maximum CP, (CP) Frequency 109	f _{max}	5*	114	—	100	—	MHz
112			114	—	100	—	
CP, (CP) Pulse Width	t _w	5	4.4	—	5	—	ns
R, S Pulse Width	t _w	5	4.8	—	5.5	—	ns
Setup Time J, K to CP (109)	t _{SU}	5	4.8	—	5.5	—	ns
J, K to CP (112)			3.5	—	4	—	
Hold Time J, K to CP (109)	t _H	5	0	—	0	—	ns
J, K to CP (112)			1	—	1	—	
Removal Time R, S to CP, (CP)	t _{REM}	5	2.2	—	2.5	—	ns

*5 V: min. is @ 4.5 V

SWITCHING CHARACTERISTICS: ACT Series; t_r, t_f = 3 ns, C_L = 50 pF

CHARACTERISTICS	SYMBOL	V _{CC} (V)	AMBIENT TEMPERATURE (T _A) - °C				UNITS
			-40 to +85		-55 to +125		
			MIN.	MAX.	MIN.	MAX.	
Propagation Delays CP, (CP) to Q, Q̄	t _{PLH} t _{PHL}	5*	2.7	9.4	2.6	10.3	ns
S, R, to Q, Q̄	t _{PLH} t _{PHL}	5	3.2	11.1	3.1	12.2	ns
Power Dissipation Capacitance	C _{PD} §	—	56 Typ.		56 Typ.		pF
Input Capacitance	C _I	—	—	10	—	10	pF

*5 V: min. is @ 5.5 V
max. is @ 4.5 V

§C_{PD} is used to determine the dynamic power consumption, per flip-flop.

$$P_D = C_{PD}V_{CC}^2 f_i + \sum (C_L V_{CC}^2 f_o) + V_{CC} \Delta I_{CC}$$

where f_i = input frequency
f_o = output frequency
C_L = output load capacitance
V_{CC} = supply voltage.

CD54/74AC109, CD54/74AC112 CD54/74ACT109, CD54/74ACT112

CD54/74AC/ACT109 Waveforms

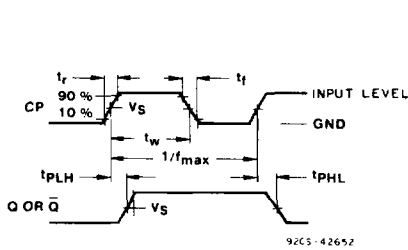

Clock to output delays and clock pulse width.

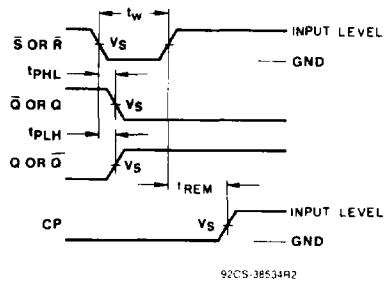

Reset or Set prerequisite and propagation delays.

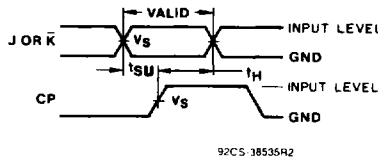

Data setup and hold times.

CD54/74/AC/ACT112 Waveforms

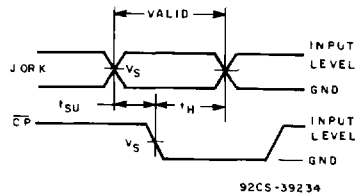
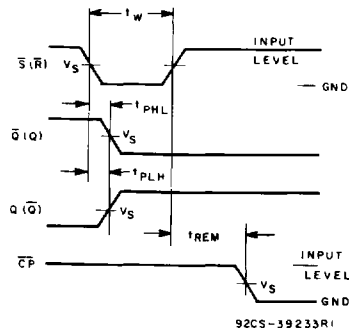
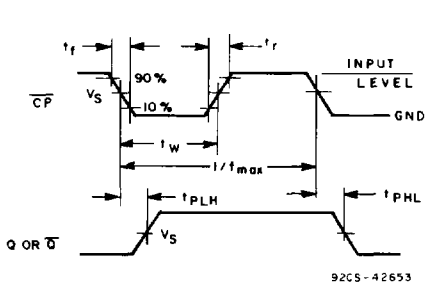

Propagation delay times, and setup and hold times.

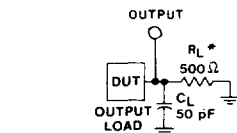

*FOR AC SERIES ONLY: WHEN
 $V_{CC} = 1.5\text{ V}$, $R_L = 1\text{ k}\Omega$

92CS-42189

Test circuit.

	CD54/74AC	CD54/74ACT
Input Level	V_{CC}	3 V
Input Switching Voltage, V_S	$0.5 V_{CC}$	1.5 V
Output Switching Voltage, V_S	$0.5 V_{CC}$	$0.5 V_{CC}$