

RECOMMENDED PANEL CUTOUT

PANEL THICKNESS	(X) DIMENSION
0.75 - 1.25	19.2
1.25 - 2.00	19.4
2.00 - 3.00	19.6

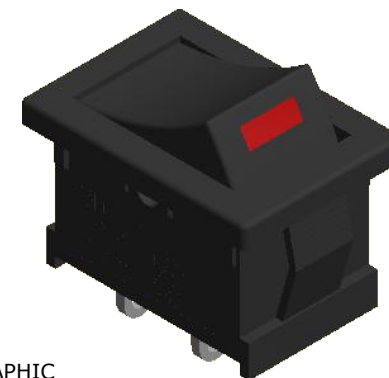
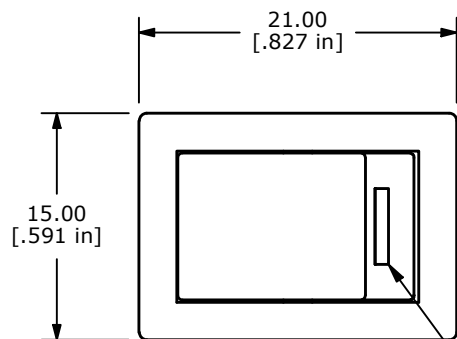

▲ CUSTOM GRAPHIC COLOR: RED

SWITCH FUNCTION	
POS. 1	POS. 2
OFF	ON
OPEN	2-1

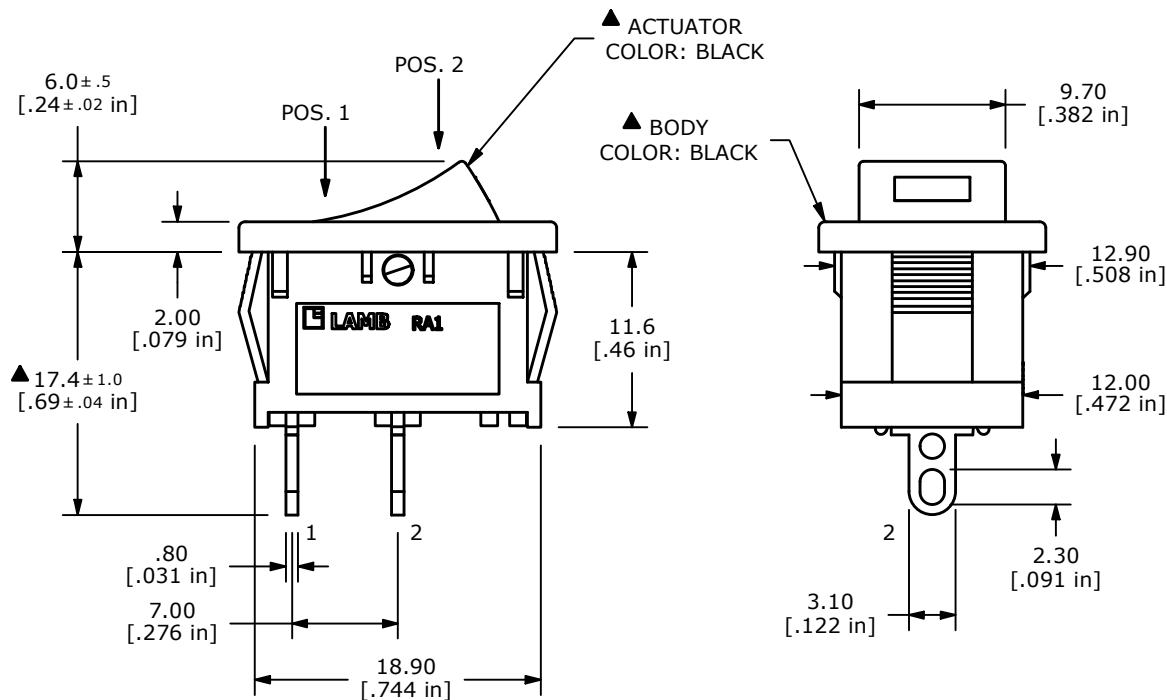
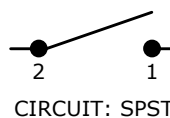

- NOTE:
1. DIMENSIONS IN MM [INCH]
 2. GENERAL TOLERANCE: X.X = ± 0.4
X.XX = ± 0.25
 3. TERMINAL NUMBERS FOR REF ONLY
 4. CONTACT MATERIAL: SILVER
 - ▲ 5. CONTACT RATINGS: 10A @ 125VAC [UR, cUR]
 6. CONTACT RESISTANCE: 35mΩ MAX. @ 50VAC
 7. INSULATION RESISTANCE: 100MΩ MIN. @ 500VAC
 8. DIELECTRIC STRENGTH: 1,500VAC FOR 1 MINUTE
 9. ELECTRICAL LIFE: 6,000 CYCLES [UR, cUR]
 10. OPERATING TEMPERATURE: -20°C TO 105°C [UR, cUR]
 11. ▲ DENOTES CRITICAL PARAMETER

REV	ECO NO	DESCRIPTION	DATE	BY
D	ECO-101272	RA1 SERIES UPDATE	10/11/22	MR
C	ECO-100450	REMOVE VDE/ENEC	01/10/22	JS



OBJECT ID
000001404

TITLE RA12131185				
SCALE 2:1	DATE 12/2/2010	DR CAB	DWG 38-RA12131185	REV D

THE INFORMATION CONTAINED IN THIS DOCUMENT IS PROPRIETARY TO E-SWITCH AND IS NOT TO BE COPIED OR TRANSFERRED