



Transient Voltage Suppressor

Breakdown Voltage 6.8 to 440 Volts
Peak Pulse Power 600 Watts

Features

- Breakdown Voltages (V_{BR}) from 6.8 to 440V
- 600W peak pulse power capability with a 10/1000 μ s waveform, repetitive rate (duty cycle):0.01%
- Fast Response Time
- Low incremental surge resistance
- Excellent clamping capability
- Available in uni-directional and bi-directional
- High temperature soldering guaranteed: 265 $^{\circ}$ C /10 seconds, 0.375" (9.5mm) lead length, 5lbs. (2.3kg) tension

Application

- Use in sensitive electronics protection against voltage transients induced by inductive load switching and lighting on ICs, MOSFE, signal lines of sensor units for consumer, computer, industrial, automotive and telecommunication

Mechanical Data

- **Case:** Void-free transfer molded thermosetting epoxy body meeting UL94V-O
- **Terminals:** Tin-Lead or ROHS Compliant annealed matte-Tin plating readily solderable per MIL-STD-750, Method 2026
- **Marking:** Body marked with part number
- **Polarity:** Cathode indicated by band. No marking on bi-directional devices
- **Weight:** 0.093g (Approximately)

CASE: SMB (DO214AA)

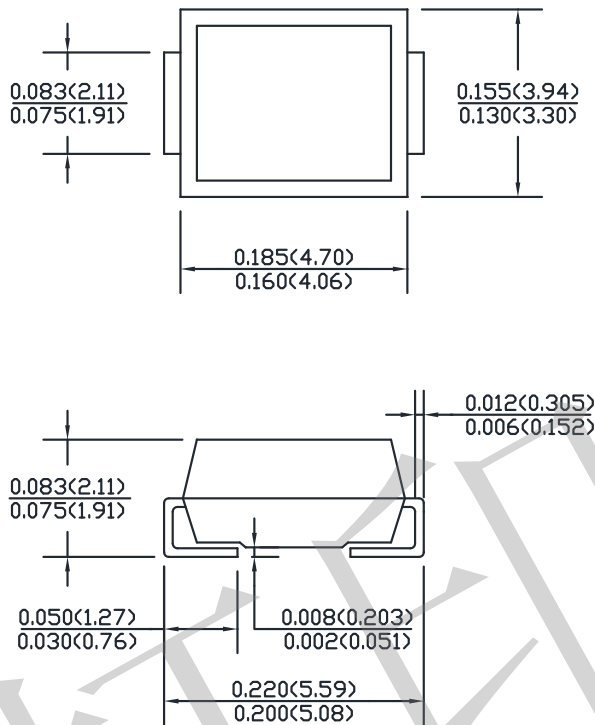

Dimensions in inches and (millimeters)

Maximum Ratings and Electrical Characteristics @ 25 $^{\circ}$ C unless otherwise specified

Symbol	Conditions	Value	Unit
P_{PPM}	Peak pulse power capability with a 10/1000 μ s	600	W
I_{PPM}	Peak pulse current with a 10/1000 μ s	SEE TABLE 1	A
$P_{M(AV)}$	Steady state power dissipation at $T_L=25^{\circ}$ C, Lead lengths 0.375"(10mm)	5.0	W
	Steady state power dissipation at $T_A=25^{\circ}$ C when mounted on FR4 PC described for thermal resistance	1.38	W
I_{FSM}	Peak forward surge current, 8.3ms single half sine-wave unidirectional only(1)	100	A
V_F	Maximum instantaneous forward voltage at 30A for unidirectional only	3.5/5.0	V
$R_{\theta JL}$	Thermal resistance junction to lead	25	$^{\circ}$ C/W
$R_{\theta JA}$	Thermal resistance junction to ambient	90	$^{\circ}$ C/W
T_J, T_{STG}	Operating and Storage Temperature	-65 to +150	$^{\circ}$ C

Notes:

- (1) Measured on 8.3ms single half sine-wave or equivalent square wave, duty cycle=4 pulses per minute maximum
- (2) $V_F=3.5V$ for P4KE220(A) and below; $V_F=5.0V$ for P4KE250(A) and above



Electrical Characteristics @ 25°C (Unless Otherwise Noted) TABLE1

Microsemi Part Number	Breakdown Voltage V_{BR} @ I_{BR}			Rated Stand Off Voltage $V_{WM}(V)$	Maximum Standby current I_D @ V_{WM}	Maximum Peak Pulse Current I_{PP} (A)	Maximum Clamping Voltage V_C @ I_{PP}	Maximum Temperature Coefficient of $V_{(BR)}$ $\alpha_{V(BR)}$ (%/°C)
	MIN	MAX						
	$V_{BR}(V)$		$I_{BR}(mA)$					
SMBJP6KE6.8	6.12	7.48	10	5.50	1000	56.0	10.8	.057
SMBJP6KE6.8A	6.45	7.14	10	5.80	1000	57.0	10.5	.057
SMBJP6KE7.5	6.75	8.25	10	6.05	500	51.0	11.7	.061
SMBJP6KE7.5A	7.13	7.88	10	6.40	500	53.0	11.3	.061
SMBJP6KE8.2	7.38	9.02	10	6.63	200	48.0	12.5	.065
SMBJP6KE8.2A	7.79	8.61	10	7.02	200	50.0	12.1	.065
SMBJP6KE9.1	8.19	10.0	1	7.37	50	44.0	13.8	.068
SMBJP6KE9.1A	8.65	9.55	1	7.78	50	45.0	13.4	.068
SMBJP6KE10	9.0	11.0	1	8.10	10	40.0	15.0	.073
SMBJP6KE10A	9.5	10.5	1	8.55	10	41.0	14.5	.073
SMBJP6KE11	9.9	12.1	1	8.92	5	37.0	16.2	.075
SMBJP6KE11A	10.5	11.6	1	9.40	5	38.0	15.6	.075
SMBJP6KE12	10.8	13.2	1	9.72	5	35.0	17.3	.078
SMBJP6KE12A	11.4	12.6	1	10.2	5	36.0	16.7	.078
SMBJP6KE13	11.7	14.3	1	10.5	5	32.0	19.0	.081
SMBJP6KE13A	12.4	13.7	1	11.1	5	33.0	18.2	.081
SMBJP6KE15	13.5	16.5	1	12.1	1	27.0	22.0	.084
SMBJP6KE15A	14.3	15.8	1	12.8	1	28.0	21.2	.084
SMBJP6KE16	14.4	17.6	1	12.9	1	26.0	23.5	.086
SMBJP6KE16A	15.2	16.8	1	13.6	1	27.0	22.5	.086
SMBJP6KE18	16.2	19.8	1	14.5	1	23.0	26.5	.088
SMBJP6KE18A	17.1	18.9	1	15.3	1	24.0	25.2	.088
SMBJP6KE20	18.0	22.0	1	16.2	1	21.0	29.1	.090
SMBJP6KE20A	19.0	21.0	1	17.1	1	22.0	27.7	.090
SMBJP6KE22	19.8	24.2	1	17.8	1	19.0	31.9	.092
SMBJP6KE22A	20.9	23.1	1	18.8	1	20.0	30.6	.092
SMBJP6KE24	21.6	26.4	1	19.4	1	17.0	34.7	.094
SMBJP6KE24A	22.8	25.2	1	20.5	1	18.0	33.2	.094
SMBJP6KE27	24.3	29.7	1	21.8	1	15.0	39.1	.096
SMBJP6KE27A	25.7	28.4	1	23.1	1	16.0	37.5	.096
SMBJP6KE30	27.0	33.0	1	24.3	1	14.0	43.5	.097
SMBJP6KE30A	28.5	31.5	1	25.6	1	14.4	41.4	.097
SMBJP6KE33	29.7	36.3	1	26.8	1	12.6	47.7	.098
SMBJP6KE33A	31.4	34.7	1	28.2	1	13.2	45.7	.098
SMBJP6KE36	32.4	39.6	1	29.1	1	11.6	52.0	.099
SMBJP6KE36A	34.2	37.8	1	30.8	1	12.0	49.9	.099
SMBJP6KE39	35.1	42.9	1	31.6	1	10.6	56.4	.100
SMBJP6KE39A	37.1	41.0	1	33.3	1	11.2	53.9	.100
SMBJP6KE43	38.7	47.3	1	34.8	1	9.6	61.9	.101
SMBJP6KE43A	40.9	45.2	1	36.8	1	10.1	59.3	.101
SMBJP6KE47	42.3	51.7	1	38.1	1	8.8	67.8	.101
SMBJP6KE47A	44.7	49.4	1	40.2	1	9.3	64.8	.101
SMBJP6KE51	45.9	56.1	1	41.3	1	8.2	73.5	.102
SMBJP6KE51A	48.5	53.6	1	43.6	1	8.6	70.1	.102
SMBJP6KE56	50.4	61.6	1	45.4	1	7.4	80.5	.103
SMBJP6KE56A	53.2	58.8	1	47.8	1	7.8	77.0	.103
SMBJP6KE62	55.8	68.2	1	50.2	1	6.8	89.0	.104
SMBJP6KE62A	58.9	65.1	1	53.0	1	7.1	85.0	.104
SMBJP6KE68	61.2	74.8	1	55.1	1	6.1	98.0	.104
SMBJP6KE68A	64.6	71.4	1	58.1	1	6.5	92.0	.104
SMBJP6KE75	67.5	82.5	1	60.7	1	5.5	108.0	.105
SMBJP6KE75A	71.3	78.8	1	64.1	1	5.8	103.0	.105

Electrical Characteristics @ 25°C (Unless Otherwise Noted) TABLE1

Microsemi Part Number	Breakdown Voltage V_{BR} @ I_{BR}			Rated Stand Off Voltage	Maximum Standby current I_D @ V_{WM}	Maximum Peak Pulse Current	Maximum Clamping Voltage V_C @ I_{PP}	Maximum Temperature Coefficient of V_{BR}
	MIN	MAX						
	$V_{BR}(V)$		$I_{BR}(mA)$					
SMBJP6KE82	73.8	90.2	1	66.4	1	5.1	118.0	.105
SMBJP6KE82A	77.9	86.1	1	70.1	1	5.3	113.0	.105
SMBJP6KE91	81.9	100.0	1	73.7	1	4.5	131.0	.106
SMBJP6KE91A	86.5	95.5	1	77.8	1	4.8	125.0	.106
SMBJP6KE100	90.0	110.0	1	81.0	1	4.2	144.0	.106
SMBJP6KE100A	95.0	105.0	1	85.5	1	4.4	137.0	.106
SMBJP6KE110	99.0	121.0	1	89.2	1	3.8	158.0	.107
SMBJP6KE110A	105.0	116.0	1	94.0	1	4.4	152.0	.107
SMBJP6KE120	108.0	132.0	1	97.2	1	3.5	173.0	.107
SMBJP6KE120A	114.0	126.0	1	102.0	1	3.6	165.0	.107
SMBJP6KE130	117.0	143.0	1	105.0	1	3.2	187.0	.107
SMBJP6KE130A	124.0	137.0	1	111.0	1	3.3	179.0	.107
SMBJP6KE150	135.0	165.0	1	121.0	1	2.8	215.0	.108
SMBJP6KE150A	143.0	158.0	1	128.0	1	2.9	207.0	.108
SMBJP6KE160	144.0	176.0	1	130.0	1	2.6	230.0	.108
SMBJP6KE160A	152.0	168.0	1	136.0	1	2.7	219.0	.108
SMBJP6KE170	153.0	187.0	1	138.0	1	2.5	244.0	.108
SMBJP6KE170A	161.0	179.0	1	145.0	1	2.6	234.0	.108
SMBJP6KE180	162.0	198.0	1	146.0	1	2.3	258.0	.108
SMBJP6KE180A	171.0	189.0	1	154.0	1	2.4	246.0	.108
SMBJP6KE200	180.0	220.0	1	162.0	1	2.1	287.0	.108
SMBJP6KE200A	190.0	210.0	1	171.0	1	2.2	274.0	.108
SMBJP6KE220	198.0	242.0	1	175.0	1	1.8	344.0	.110
SMBJP6KE220A	209.0	231.0	1	185.0	1	1.9	328.0	.110
SMBJP6KE250	225.0	275.0	1	202.0	1	1.7	360.0	.110
SMBJP6KE250A	237.0	263.0	1	214.0	1	1.8	344.0	.110
SMBJP6KE300	270.0	330.0	1	243.0	1	1.4	430.0	.110
SMBJP6KE300A	285.0	315.0	1	256.0	1	1.5	414.0	.110
SMBJP6KE350	315.0	385.0	1	284.0	1	1.2	504.0	.110
SMBJP6KE350A	332.0	368.0	1	300.0	1	1.3	482.0	.110
SMBJP6KE400	360.0	440.0	1	324.0	1	1.1	574.0	.110
SMBJP6KE400A	380.0	420.0	1	342.0	1	1.1	548.0	.110
SMBJP6KE440	396.0	484.0	1	356.0	1	1.0	631.0	.110
SMBJP6KE440A	418.0	462.0	1	376.0	1	1.0	600.0	.110

1. For bi-directional construction, indicate a C or CA suffix after part number, i.e. SMBJP6KE6.8C or SMBJP6KE440CA



Characteristic Curve

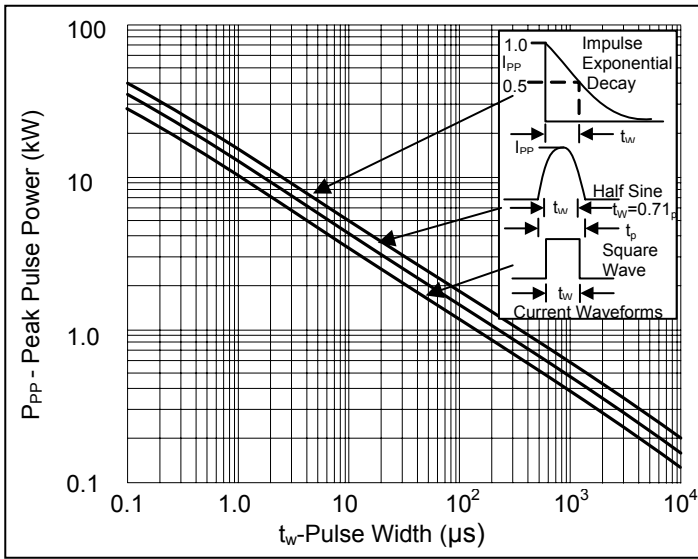

Fig. 1 Peak Pulse Power vs. Pulse Time

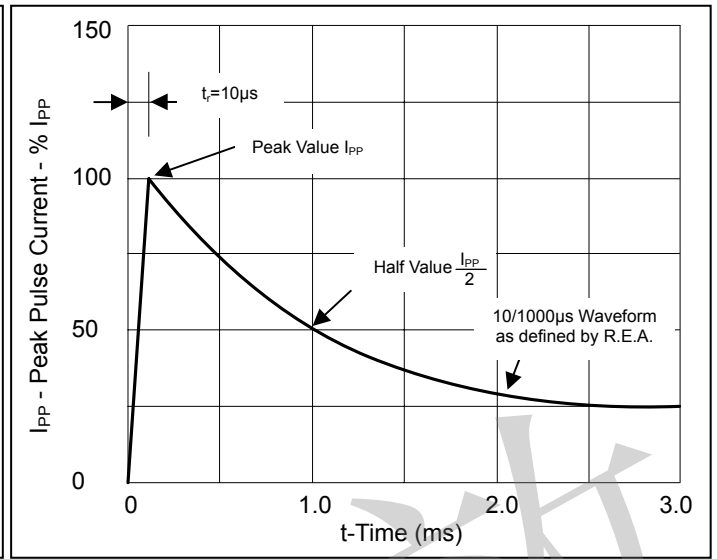

Fig. 2 Pulse Waveform for Exponential Surge

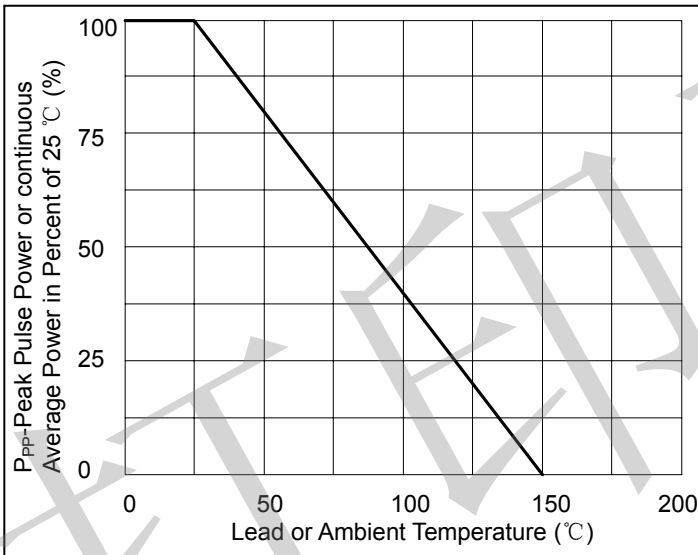

Fig. 3 Derating Curve

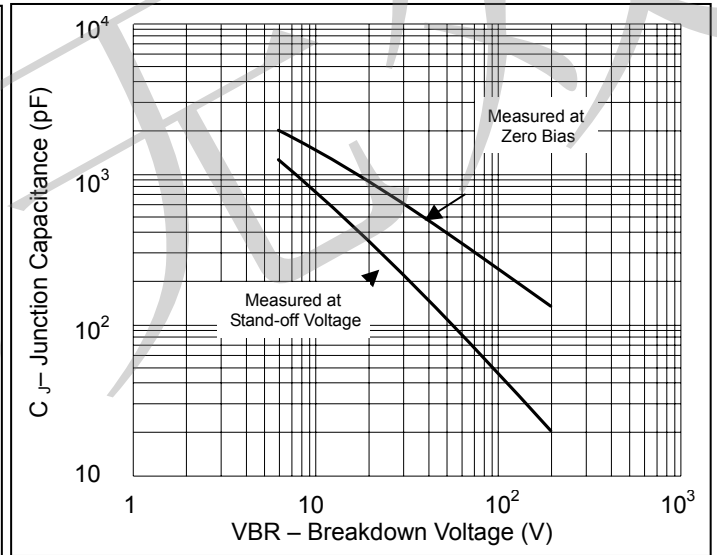

Fig. 4 Typical Capacitance vs. Breakdown Voltage (Unipolar)

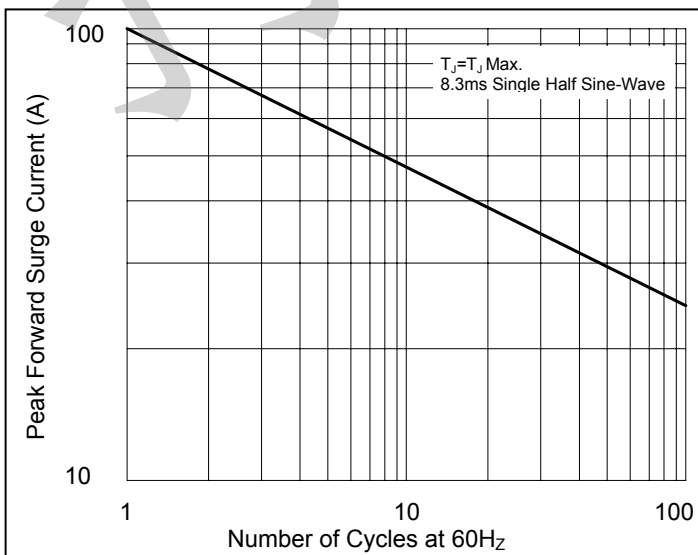

Fig. 5 Max. Non-Repetitive Forward Surge Current Uni-Directional Only