

SANKEN

SANKEN
LIGHT EMITTING DIODES

T-1 High Intensity Type (Diffused)

SEL 2210 R SEL 2810 D
SEL 2210 W SEL 2910 D
SEL 2410 G

FEATURES

- High Intensity Type
- Mounting Requires Only a Small Space
- Long-life/High Reliability
- Wide Viewing Angle/Diffused type
- Selection of 4 Colors/Intensities
- Pulse-Drivable
- CMOS/MOS, TTL Compatible

APPLICATIONS

- Panel Backlight, Display of Keyboards
- Portable Device
- LED Electric Signs
- For PCB Checking
- Display of Battery and Communication Devices

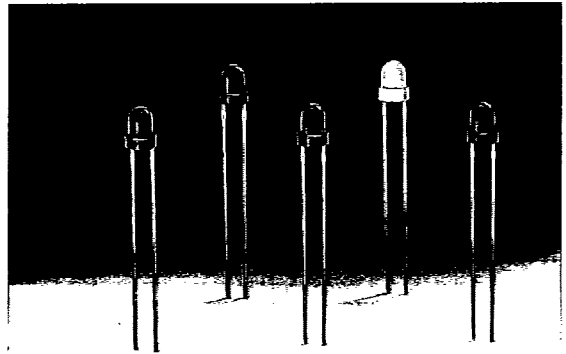

Package Dimensions

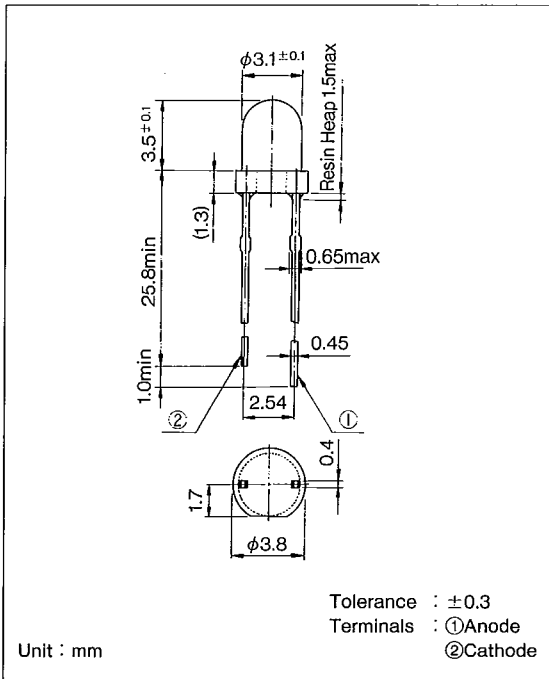

Intensity Ranks

Type No.	Intensity Min. (mcd)	Condition I _F (mA)	Color	
			Lens	Chip
SEL 2210 R A	3.0	20	R	HIR
B	3.7			
C	4.7			
D	6.8			
SEL 2210 W A	3.0	20	W	HIR
B	3.7			
C	4.7			
D	6.8			
SEL 2410 G A	3.0	20	G	HIG
B	5.0			
C	7.0			
D	10.0			
SEL 2810 D A	2.5	10	O	A
B	3.4			
C	4.4			
D	6.0			
SEL 2910 D A	1.2	10	O	O
B	2.0			
C	2.9			
D	3.9			

R=Red G=Green O=Orange W=Opaline A=Amber HIR=High Intensity Red HIG=High Intensity Green

Electro-Optical Characteristics (Ta = 25°C)							
Symbol	Description	Type No.	Min.	Typ.	Max.	Unit	Test Condition
I _v	Intensity	SEL 2210 R, 2210W	3.0	6.8		mcd	I _F =20 (mA)
		SEL 2410 G	3.0	10.0			I _F =10 (mA)
		SEL 2810 D	2.5	6.0			
		SEL 2910 D	1.2	3.9			
2θ _{1/2}	Including Angle Between Half Intensity Points	SEL 2210 R, 2210W SEL 2410 G SEL 2810 D SEL 2910 D		60°		Deg	I _F =10 (mA) See Note 1
λ _p	Peak Wavelength	SEL 2210 R, 2210W SEL 2410 G SEL 2810 D SEL 2910 D		635 560 612 583		nm	I _F =10 (mA)
Δλ	Spectral Line Halfwidth	SEL 2210 R, 2210W SEL 2410 G SEL 2810 D SEL 2910 D		40 28 40 36		nm	
λ _d	Dominant Wavelength	SEL 2210 R, 2210W SEL 2410 G SEL 2810 D SEL 2910 D		626 562 608 585		nm	See Note 2
C	Capacitance	SEL 2210 R, 2210W SEL 2410 G SEL 2810 D SEL 2910 D		15 15 15 10		pF	V _F =0 f=1 (MHz)
V _F	DC Forward Voltage	SEL 2210 R, 2210W SEL 2410 G SEL 2810 D SEL 2910 D	1.5	2.0	3.0	V	I _F =10 (mA)
V _R	DC Reverse Voltage	SEL 2210 R, 2210W SEL 2410 G SEL 2810 D SEL 2910 D	5.0			V	I _R =100 (μA)

- Notes : 1. θ_{1/2} is the off-axis angle at which the intensity is half the axial intensity.
 2. The dominant wavelength, λ_d, is derived from the CIE chromaticity diagram and it represents the single wavelength which defines the color of the device.

Absolute Maximum Ratings (Ta = 25°C)

Symbol	Description	Ratings	Unit
I_P	Peak Forward Current*1	100	mA
I_F	Max. DC Forward Current*2	30	mA
V_R	DC Reverse Voltage ($I_R=100\mu A$)	5	V
I_{FP}	Transient Max. Peak Forward Current*3 (10 μ sec Pulse)	500	mA
T_{op}	Operating Temp. Range	-55 to +100	°C
T_{stg}	Storage Temp. Range	-55 to +100	
T_{sld}	Lead Soldering Temp. (more than 4.0 mm from body)	260° C for 5 seconds	

- Notes : 1. See Figure 4
 2. This current derates linearly from 25°C at 0.33 mA/°C
 3. Only for one pulse

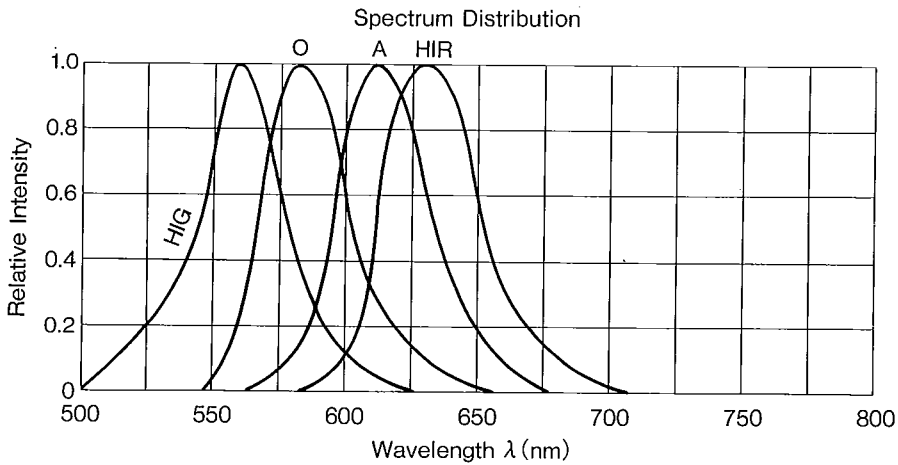

Fig. 1 : Relative Intensity vs. Wavelength

Individual Specifications

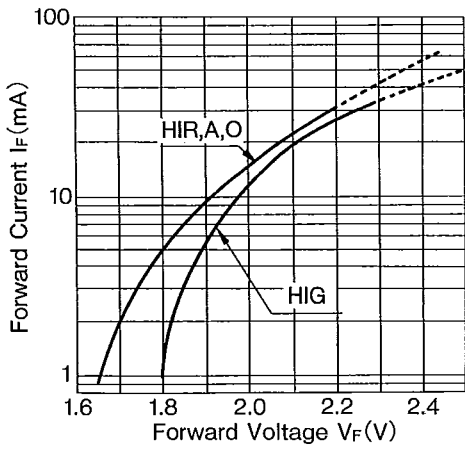

Fig.2 : Forward Current vs. Forward Voltage

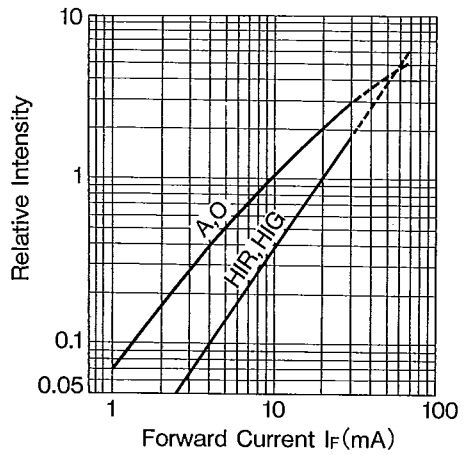

Fig.3 : Relative Intensity vs. Forward Current

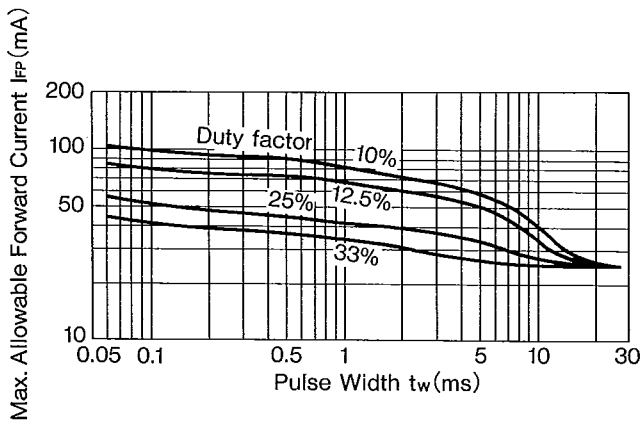

Fig.4 : Max. Allowable Forward Current vs. Pulse Width

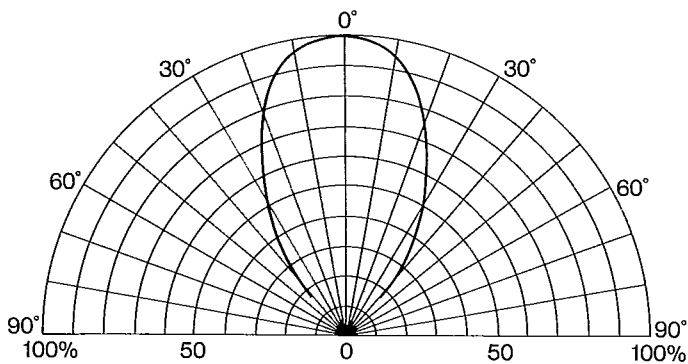

Fig.5 : Viewing Angle