



Integrated Device Technology, Inc.

# CMOS STATIC RAM 1 MEG (256K x 4-BIT)

IDT71028

### FEATURES:

- 256K x 4 advanced high-speed CMOS static RAM
- Equal access and cycle times
  - Military: 15/17/20/25ns
  - Commercial: 12/15/17ns
- One Chip Select plus one Output Enable pin
- Bidirectional data Inputs and outputs directly TTL-compatible
- Low power consumption via chip deselect
- Available in 28-pin Ceramic DIP, Plastic DIP, 300 mil and 400 mil Plastic SOJ, and LCC packages
- Military product compliant to MIL-STD-883, Class B

### DESCRIPTION:

The IDT71028 is a 1,024,576-bit high-speed static RAM organized as 256K x 4. It is fabricated using IDT's high-performance, high-reliability CMOS technology. This state-of-the-art technology, combined with innovative circuit design techniques, provides a cost-effective solution for high-speed memory needs.

The IDT71028 has an output enable pin which operates as fast as 6ns, with address access times as fast as 12ns. All bidirectional inputs and outputs of the IDT71028 are TTL-compatible and operation is from a single 5V supply. Fully static asynchronous circuitry is used, requiring no clocks or refresh for operation.

The IDT71028 is packaged in 28-pin 400 mil Ceramic DIP, 28-pin 400 mil Plastic DIP, 28-pin 300 mil Plastic SOJ, 28-pin 400 mil Plastic SOJ, and 28-pin Leadless Chip Carrier packages.

### FUNCTIONAL BLOCK DIAGRAM

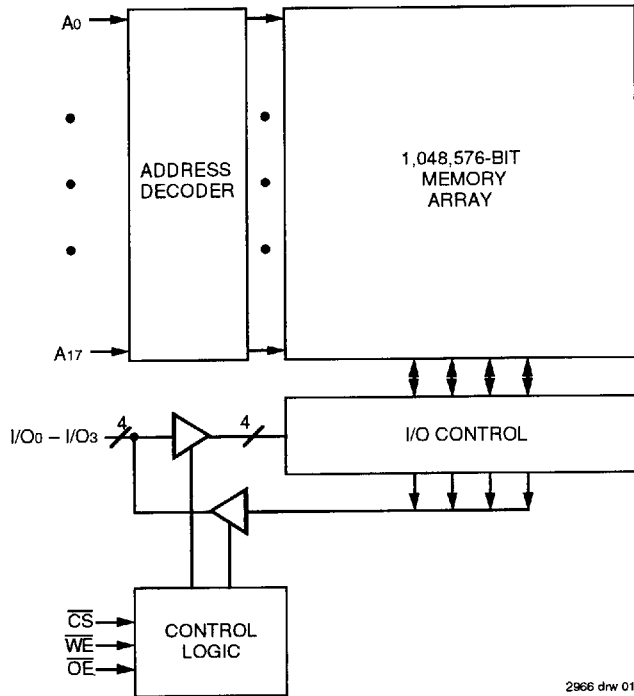

The IDT logo is a registered trademark of Integrated Device Technology, Inc.

MILITARY AND COMMERCIAL TEMPERATURE RANGES

MAY 1994

©1994 Integrated Device Technology, Inc.

8.1

DSC-10123

1

4825771 0015164 425

**PIN CONFIGURATION**

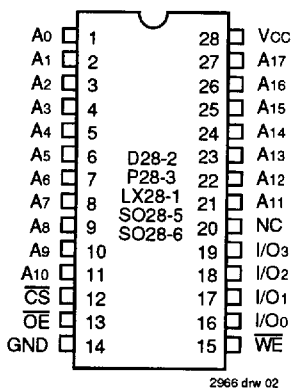

DIP/SOJ/LCC  
TOP VIEW

**ABSOLUTE MAXIMUM RATINGS<sup>(1)</sup>**

Symbol	Rating	Com'l.	MIL.	Unit
VTERM <sup>(2)</sup>	Terminal Voltage with Respect to GND	-0.5 to +7.0	-0.5 to +7.0	V
TA	Operating Temperature	0 to +70	-55 to +125	°C
TBIAS	Temperature Under Bias	-55 to +125	-65 to +135	°C
TSTG	Storage Temperature	-55 to +125	-65 to +150	°C
PT	Power Dissipation	1.25	1.25	W
IOUT	DC Output Current	50	50	mA

**NOTES:**

- 1 Stresses greater than those listed under ABSOLUTE MAXIMUM RATINGS may cause permanent damage to the device. This is a stress rating only and functional operation of the device at these or any other conditions above those indicated in the operational sections of this specification is not implied. Exposure to absolute maximum rating conditions for extended periods may affect reliability.
- 2 VTERM must not exceed Vcc + 0.5V

**TRUTH TABLE<sup>(1,2)</sup>**

CS	OE	WE	I/O	Function
L	L	H	DATAOUT	Read Data
L	X	L	DATAIN	Write Data
L	H	H	High-Z	Output Disabled
H	X	X	High-Z	Deselected - Standby (ISB)
VHC <sup>(3)</sup>	X	X	High-Z	Deselected - Standby (ISB1)

**NOTES:**

- 1 H = VIH, L = VIL, X = Don't care
- 2 VLC = 0.2V, VHC = Vcc - 0.2V.
- 3 Other inputs ≥ VHC or ≤ VLC

**CAPACITANCE**

(TA = +25°C, f = 1.0MHz, SOJ package)

Symbol	Parameter <sup>(1)</sup>	Conditions	Max.	Unit
CIN	Input Capacitance	VIN = 3dV	8	pF
CIO	I/O Capacitance	VOUT = 3dV	8	pF

**NOTE:**

- 1 This parameter is guaranteed by device characterization, but not production tested

**RECOMMENDED DC OPERATING CONDITIONS**

Symbol	Parameter	Min.	Typ.	Max.	Unit
VCC	Supply Voltage	4.5	5.0	5.5	V
GND	Supply Voltage	0	0	0	V
VIH	Input High Voltage	2.2	—	Vcc+0.5	V
VIL	Input Low Voltage	-0.5 <sup>(1)</sup>	—	0.8	V

**NOTE:**

- 1 VIL (min) = -1.5V for pulse width less than 10ns, once per cycle.

**DC ELECTRICAL CHARACTERISTICS**

Vcc = 5.0V ± 10%

Symbol	Parameter	Test Condition	IDT71028		Unit
			Min.	Max.	
IL	Input Leakage Current	Vcc = Max., VIN = GND to Vcc	—	5	µA
LO	Output Leakage Current	Vcc = Max., CS = VIH, VOUT = GND to Vcc	—	5	µA
VOL	Output Low Voltage	IOL = 8mA, Vcc = Min	—	0.4	V
VOH	Output High Voltage	IOH = -4mA, Vcc = Min.	2.4	—	V

2966 tbl 05



**DC ELECTRICAL CHARACTERISTICS<sup>(1)</sup>**

(V<sub>CC</sub> = 5.0V ± 10%, V<sub>LC</sub> = 0.2V, V<sub>HC</sub> = V<sub>CC</sub> - 0.2V)

Symbol	Parameter	71028S12 <sup>(2)</sup>		71028S15		71028S17		71028S20		71028S25		Unit
		Com'l.	Mil.	Com'l.	Mil.	Com'l.	Mil.	Com'l.	Mil.	Com'l.	Mil.	
I <sub>CC</sub>	Dynamic Operating Current, $\overline{CS} \leq V_{IL}$ , Outputs Open, V <sub>CC</sub> = Max, f = f <sub>MAX</sub> <sup>(2)</sup>	155	—	150	175	145	165	—	155	—	140	mA
I <sub>SB</sub>	Standby Power Supply Current (TTL Level), $\overline{CS} \geq V_{IH}$ , Outputs Open, V <sub>CC</sub> = Max, f = f <sub>MAX</sub> <sup>(2)</sup>	35	—	35	45	35	40	—	40	—	35	mA
I <sub>SB1</sub>	Full Standby Power Supply Current (CMOS Level), $\overline{CS} \geq V_{HC}$ , Outputs Open, V <sub>CC</sub> = Max, f = 0 <sup>(2)</sup> , V <sub>IN</sub> ≤ V <sub>LC</sub> or V <sub>IN</sub> ≥ V <sub>HC</sub>	10	—	10	15	10	15	—	15	—	15	mA

2966 tbl 06

**NOTES:**

- 1 All values are maximum guaranteed values
2. f<sub>MAX</sub> = 1/trc (all address inputs are cycling at f<sub>MAX</sub>), f = 0 means no address input lines are changing.
3. 12ns specification is preliminary.

**AC TEST CONDITIONS**

Input Pulse Levels	GND to 3.0V
Input Rise/Fall Times	3ns
Input Timing Reference Levels	1.5V
Output Reference Levels	1.5V
AC Test Load	See Figures 1 and 2

2966 tbl 07

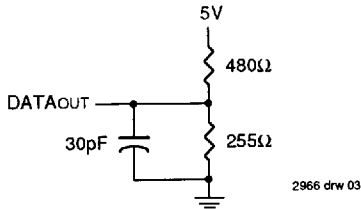

2966 drw 03

Figure 1. AC Test Load

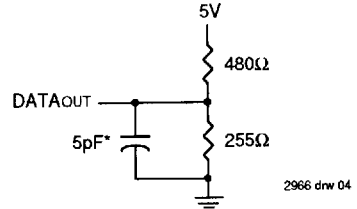

2966 drw 04

\*Including jig and scope capacitance

Figure 2. AC Test Load  
(for t<sub>CLZ</sub>, t<sub>OLZ</sub>, t<sub>CHZ</sub>, t<sub>OHZ</sub>, t<sub>LOW</sub>, and t<sub>WHZ</sub>)

**AC ELECTRICAL CHARACTERISTICS** (V<sub>CC</sub> = 5.0V ± 10%, All Temperature Ranges)

Symbol	Parameter	71028S12 <sup>(1)</sup>		71028S15		71028S17		71028S20 <sup>(2)</sup>		71028S25 <sup>(2)</sup>		Unit
		Min.	Max.	Min.	Max.	Min.	Max.	Min.	Max.	Min.	Max.	
<b>Read Cycle</b>												
t <sub>RC</sub>	Read Cycle Time	12	—	15	—	17	—	20	—	25	—	ns
t <sub>AA</sub>	Address Access Time	—	12	—	15	—	17	—	20	—	25	ns
t <sub>ACS</sub>	Chip Select Access Time	—	12	—	15	—	17	—	20	—	25	ns
t <sub>CLZ</sub> <sup>(3)</sup>	Chip Select to Output in Low-Z	3	—	3	—	3	—	3	—	3	—	ns
t <sub>CHZ</sub> <sup>(3)</sup>	Chip Deselect to Output in High-Z	0	6	0	7	0	8	0	8	0	10	ns
t <sub>OE</sub>	Output Enable to Output Valid	—	6	—	7	—	8	—	8	—	10	ns
t <sub>OLZ</sub> <sup>(3)</sup>	Output Enable to Output in Low-Z	0	—	0	—	0	—	0	—	0	—	ns
t <sub>OHZ</sub> <sup>(3)</sup>	Output Disable to Output in High-Z	0	5	0	5	0	6	0	7	0	10	ns
t <sub>OH</sub>	Output Hold from Address Change	2	—	2	—	2	—	2	—	2	—	ns
t <sub>PU</sub> <sup>(3)</sup>	Chip Select to Power Up Time	0	—	0	—	0	—	0	—	0	—	ns
t <sub>PD</sub> <sup>(3)</sup>	Chip Deselect to Power Down Time	—	12	—	15	—	17	—	20	—	25	ns
<b>Write Cycle</b>												
t <sub>WC</sub>	Write Cycle Time	12	—	15	—	17	—	20	—	25	—	ns
t <sub>AW</sub>	Address Valid to End of Write	10	—	12	—	13	—	15	—	15	—	ns
t <sub>CW</sub>	Chip Select to End of Write	10	—	12	—	13	—	15	—	15	—	ns
t <sub>AS</sub>	Address Set-up Time	0	—	0	—	0	—	0	—	0	—	ns
t <sub>WP</sub>	Write Pulse Width	10	—	12	—	13	—	15	—	15	—	ns
t <sub>WR</sub>	Write Recovery Time	0	—	0	—	0	—	0	—	0	—	ns
t <sub>DW</sub>	Data Valid to End of Write	7	—	8	—	9	—	9	—	10	—	ns
t <sub>DH</sub>	Data Hold Time	0	—	0	—	0	—	0	—	0	—	ns
t <sub>OW</sub> <sup>(3)</sup>	Output Active from End of Write	3	—	3	—	3	—	4	—	4	—	ns
t <sub>WHZ</sub> <sup>(3)</sup>	Write Enable to Output in High-Z	0	5	0	5	0	7	0	8	0	9	ns

**NOTES:**

- 0° to +70°C temperature range only. 12ns specification is preliminary
- 55°C to +125°C temperature range only
- This parameter guaranteed with the AC load (Figure 2) by device characterization, but is not production tested.

2966 tbl 08



**TIMING WAVEFORM OF READ CYCLE NO. 1<sup>(1)</sup>**

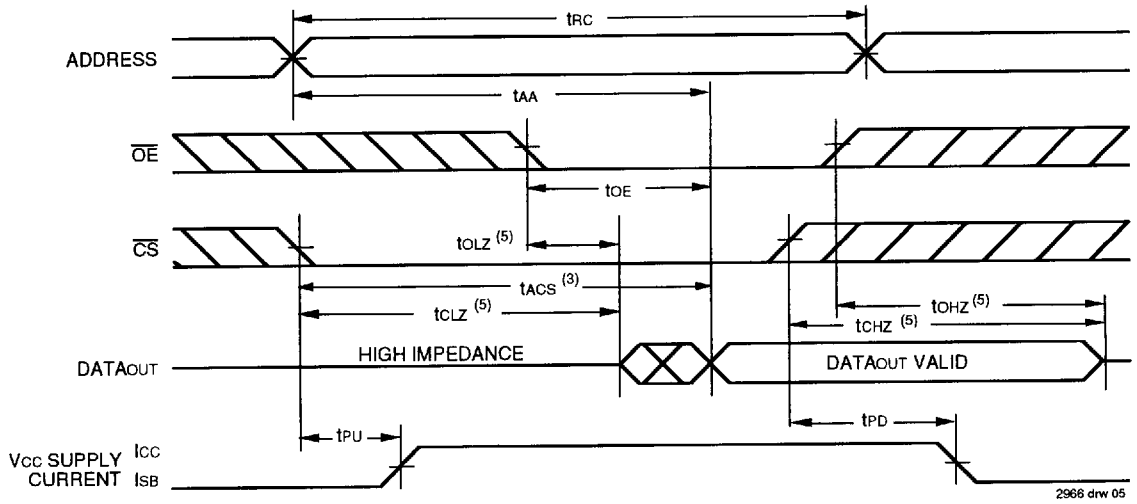

**TIMING WAVEFORM OF READ CYCLE NO. 2<sup>(1,2,4)</sup>**

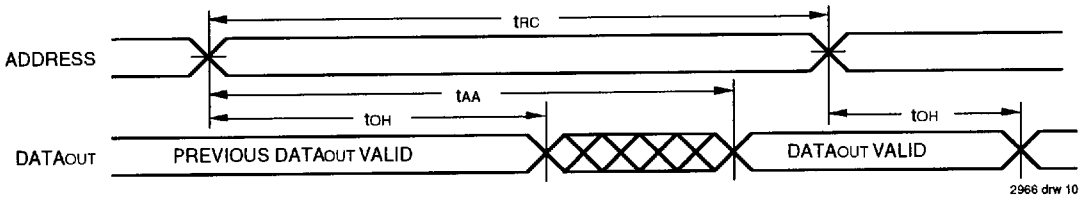

**NOTES:**

- 1 WE is HIGH for Read Cycle
- 2 Device is continuously selected, CS is LOW
- 3 Address must be valid prior to or coincident with the later of CS transition LOW; otherwise tAA is the limiting parameter.
- 4 OE is LOW
5. Transition is measured ±200mV from steady state

**TIMING WAVEFORM OF WRITE CYCLE NO.1 ( $\overline{WE}$  CONTROLLED TIMING)<sup>(1,2,3,5)</sup>**

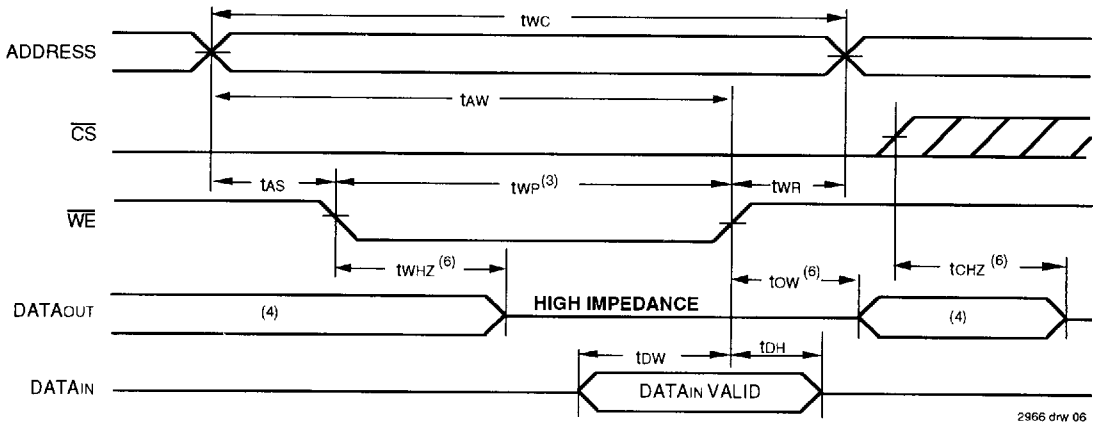

**TIMING WAVEFORM OF WRITE CYCLE NO.2 ( $\overline{CS}$  CONTROLLED TIMING)<sup>(1,2,5)</sup>**

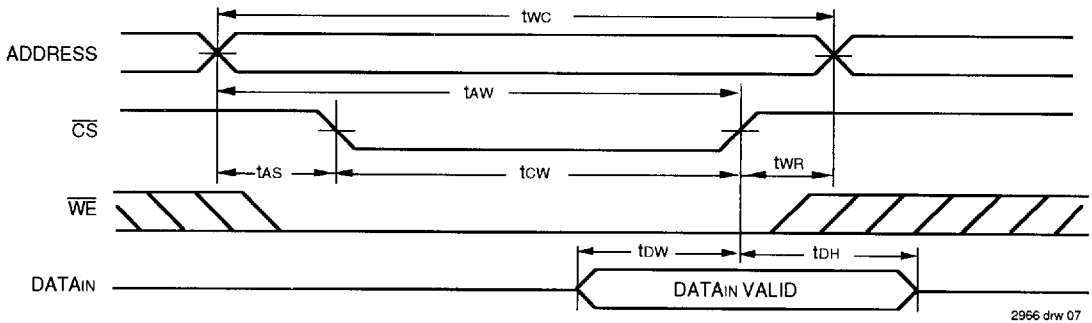

- NOTES:**
- 1  $\overline{WE}$  or  $\overline{CS}$  must be HIGH during all address transitions
  - 2 A write occurs during the overlap of a LOW  $\overline{CS}$  and a LOW  $\overline{WE}$
  - 3  $\overline{OE}$  is continuously HIGH. If during a  $\overline{WE}$  controlled write cycle  $\overline{OE}$  is LOW,  $t_{WP}$  must be greater than or equal to  $t_{WHZ} + t_{OW}$  to allow the I/O drivers to turn off and data to be placed on the bus for the required  $t_{OW}$ . If  $\overline{OE}$  is HIGH during a  $\overline{WE}$  controlled write cycle, this requirement does not apply and the minimum write pulse is as short as the specified  $t_{WP}$ .
  - 4 During this period, I/O pins are in the output state, and input signals must not be applied
  - 5 If the  $\overline{CS}$  LOW transition occurs simultaneously with or after the  $\overline{WE}$  LOW transition, the outputs remain in a high-impedance state
  - 6 Transition is measured  $\pm 200mV$  from steady state

**ORDERING INFORMATION**

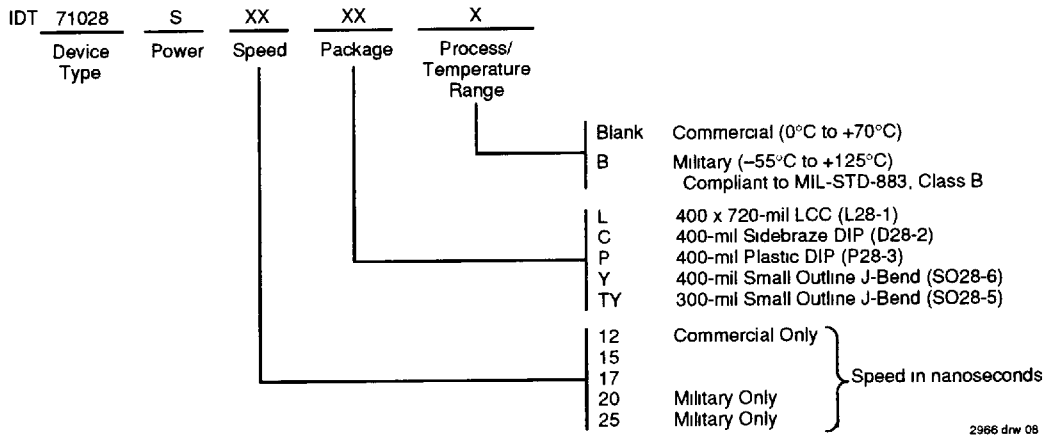

2966 drw 08