

Tous droits strictement réservés. Reproduction ou communication a des tiers interdite sous quelque forme que ce soit sans autorisation écrite du propriétaire. Propriété de c FCI. Droits de reproduction FCI.

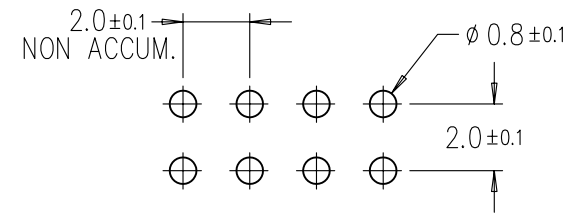

All rights strictly reserved. Reproduction or issue to third parties in any form whatever is not permitted without written authority from the proprietor. Property of FCI. Copyright FCI.

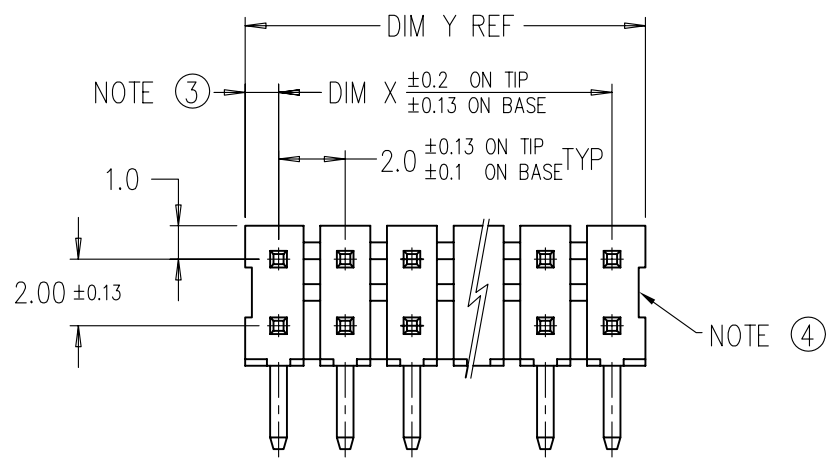

PCB THK : 1.6 ± 0.1

RECOMMENDED MOUNTING HOLE LAYOUT

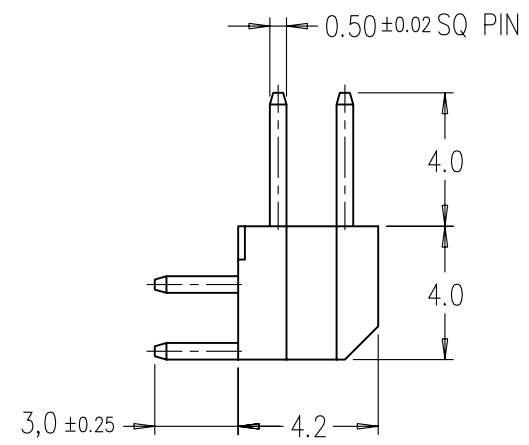
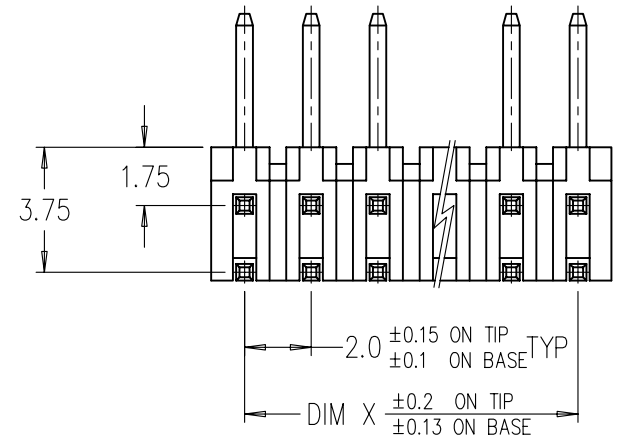

CONFIDENTIAL

| | | | | | | | | | | | | |
|-------------|----------------|-------|----------|---------------------------------------|---------|----------|----------|---------------|--------------------------------|------------------------|-------|--------|
| mat'l. code | | | | tolerances unless otherwise specified | | | | CUSTOMER COPY | | FCI www.fciconnect.com | | |
| ltr | ecn no | dr | date | linear | ±0.25 | | | projection | title | | | |
| C | S0399 | S.TAY | 1/16/90 | | | | | | MINITEK II HEADER (2 ROWS R/A) | | | |
| D | S00232 | CHWA | 9/24/90 | angles | | | | MM | product family | | code | |
| E | S00285 | BSL | 11/13/90 | | ML CHWA | | 11/13/90 | | MINITEK | | - | |
| F | S05-0053 | KBM | 2/24/05 | dr | BS LOW | 11/13/90 | scale | size | | dwg no | sheet | |
| | | | | chr | KB MAH | 2/24/05 | | A | | 86453 | | 1 of 2 |
| | | | | appd | JOEY NG | 2/24/05 | | | | | | |
| sheet index | revision sheet | F | F | | | | | | | | | |
| | | 1 | 2 | | | | | | | | | |

cage code 22526
STATUS Released

ACAD

PDM: Rev:F

Printed Jul 20, 2005

Tous droits strictement reserves. Reproduction ou communication a des tiers interdite sous quelque forme que ce soit sans autorisation écrite du propriétaire. Propriete de c FCI. Droits de reproduction FCI.



All rights strictly reserved. Reproduction or issue to third parties in any form whatever is not permitted without written authority from the proprietor. Property of FCI. Copyright FCI.

| PRODUCT NO | POS | DIM X | DIM Y |
|------------|------|--------------|-------|
| 86453-X02 | 2X1 | - OBSOLETE - | - |
| X04 | 2X2 | 2 | 4 |
| X06 | 2X3 | 4 | 6 |
| X08 | 2X4 | 6 | 8 |
| X10 | 2X5 | 8 | 10 |
| X12 | 2X6 | 10 | 12 |
| X14 | 2X7 | 12 | 14 |
| X16 | 2X8 | 14 | 16 |
| X18 | 2X9 | 16 | 18 |
| X20 | 2X10 | 18 | 20 |
| X22 | 2X11 | 20 | 22 |
| X24 | 2X12 | 22 | 24 |
| X26 | 2X13 | 24 | 26 |
| X28 | 2X14 | 26 | 28 |
| X30 | 2X15 | 28 | 30 |
| X32 | 2X16 | 30 | 32 |
| X34 | 2X17 | 32 | 34 |
| X36 | 2X18 | 34 | 36 |
| X38 | 2X19 | 36 | 38 |
| X40 | 2X20 | 38 | 40 |
| X42 | 2X21 | 40 | 42 |
| X44 | 2X22 | 42 | 44 |
| X46 | 2X23 | 44 | 46 |
| X48 | 2X24 | 46 | 48 |
| X50 | 2X25 | 48 | 50 |

PRODUCT DESCRIPTION CODE :

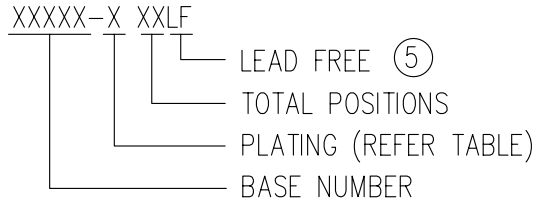

| PLATING | DESCRIPTION |
|---------|-------------|
| 0 | 0.2 um Au |
| 1 | 0.76 um Au |
| 2 | UNASSIGNED |
| 3 | 0.38 um Au |
| 4 | UNASSIGNED |
| 5 | 0.38 um GXT |
| 6 | 0.76 um GXT |

NOTES

- MATERIAL
BODY : GLASS FILLED NYLON UL 94V-0 BLACK
PIN : PHOSPHOR BRONZE
- TOLERANCE UNLESS OTHERWISE NOTED ±0,25
- (3) DIM 1.0 APPLIES TO MOLDED SIDE(S) ONLY.
IF SIDE(S) ARE SAW, DIM 0.5 MIN APPLIES.
- (4) RECESS APPLIES TO MOLDED SIDE(S) ONLY.
- (5) P/N:86453-XXXLF IS SAME AS P/N:86453-XXX. THE SUFFIX 'LF' IS ADDED JUST FOR EASY LEAD FREE IDENTIFICATION
- THE HOUSING WILL WITHSTAND EXPOSURE TO 260° C PEAK TEMPERATURE FOR 10 SECONDS IN A WAVE SOLDER APPLICATION WITH A 1.57MM MINIMUM THICK CIRCUIT BOARD.
- THIS PRODUCT MEETS EUROPEAN UNION DIRECTIVES AND OTHER COUNTRY REGULATIONS AS DESCRIBED IN GS-22-008.

CONFIDENTIAL

| | | | | | | | | | | |
|-------------|----------------|----|------|---------------------------------------|---------|----------|---------------|------------|-----------------------------------|--|
| mat'l. code | | | | tolerances unless otherwise specified | | | CUSTOMER COPY | | FCI www.fciconnect.com | |
| ltr | ecn no | dr | date | linear | ±0.25 | | | projection | title | |
| F | | | | | | | | | MINITEK II HEADER (2 ROWS R/A) | |
| | | | | angles | | | | MM | product family MINITEK | |
| | | | | dr | ML CHWA | 11/13/90 | scale | | code | |
| | | | | enrg | BS LOW | 11/13/90 | 1:1 | | size | |
| | | | | chr | KB MAH | 2/24/05 | A | | 86453 | |
| | | | | appd | JOEY NG | 2/24/05 | | | sheet | |
| sheet index | revision sheet | | | | | | | | 2 of 2 | |

cage code 22526

PDM: Rev:F

STATUS Released

Printed Jul 20, 2005

ACAD