

SN54AHCT74, SN74AHCT74 DUAL POSITIVE-EDGE-TRIGGERED D-TYPE FLIP-FLOPS WITH CLEAR AND PRESET

SCLS283B – DECEMBER 1995 – REVISED JULY 1996

- Inputs Are TTL-Voltage Compatible
- EPIC™ (Enhanced-Performance Implanted CMOS) Process
- High Latch-Up Immunity Exceeds 250 mA Per JEDEC Standard JESD-17
- ESD Protection Exceeds 2000 V Per MIL-STD-883C, Method 3015; Exceeds 200 V Using Machine Model (C = 200 pF, R = 0)
- Package Options Include Plastic Small-Outline (D), Shrink Small-Outline (DB), Thin Shrink Small-Outline (PW), and Ceramic Flat (W) Packages, Ceramic Chip Carriers (FK), and Standard Plastic (N) and Ceramic (J) 300-mil DIPs

description

The 'AHCT74 are dual positive-edge-triggered D-type flip-flops.

A low level at the preset (\overline{PRE}) or clear (\overline{CLR}) inputs sets or resets the outputs regardless of the levels of the other inputs. When \overline{PRE} and \overline{CLR} are inactive (high), data at the data (D) input meeting the setup time requirements is transferred to the outputs on the positive-going edge of the clock pulse. Clock triggering occurs at a voltage level and is not directly related to the rise time of the clock pulse. Following the hold-time interval, data at the D input can be changed without affecting the levels at the outputs.

The SN54AHCT74 is characterized for operation over the full military temperature range of -55°C to 125°C . The SN74AHCT74 is characterized for operation from -40°C to 85°C .

SN54AHCT74 ... J OR W PACKAGE
SN74AHCT74 ... D, DB, N, OR PW PACKAGE
(TOP VIEW)

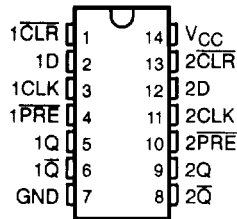

SN54AHCT74 ... FK PACKAGE
(TOP VIEW)

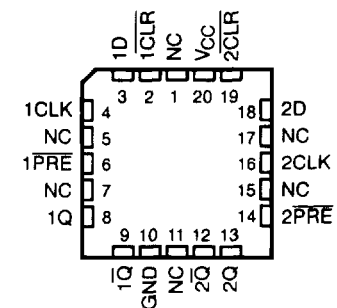

NC – No internal connection

FUNCTION TABLE

INPUTS				OUTPUTS	
PRE	CLR	CLK	D	Q	\overline{Q}
L	H	X	X	H	L
H	L	X	X	L	H
L	L	X	X	H [†]	H [†]
H	H	↑	H	H	L
H	H	↑	L	L	H
H	H	L	X	Q ₀	\overline{Q}_0

[†] This configuration is nonstable; that is, it does not persist when \overline{PRE} or \overline{CLR} returns to its inactive (high) level.

EPIC is a trademark of Texas Instruments Incorporated.

PRODUCTION DATA Information is current as of publication date. Products conform to specifications per the terms of Texas Instruments standard warranty. Production processing does not necessarily include testing of all parameters.



POST OFFICE BOX 655303 • DALLAS, TEXAS 75265

Copyright © 1996, Texas Instruments Incorporated

SN54AHCT74, SN74AHCT74
DUAL POSITIVE-EDGE-TRIGGERED D-TYPE FLIP-FLOPS
WITH CLEAR AND PRESET

SCLS263B - DECEMBER 1995 - REVISED JULY 1996

logic symbol†

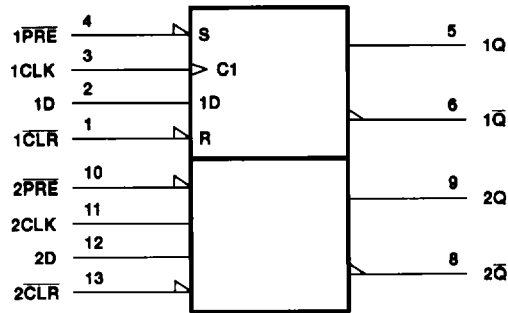

† This symbol is in accordance with ANSI/IEEE Std 91-1984 and IEC Publication 617-12. Pin numbers shown are for the D, DB, J, N, PW, and W packages.

logic diagram, each flip-flop (positive logic)

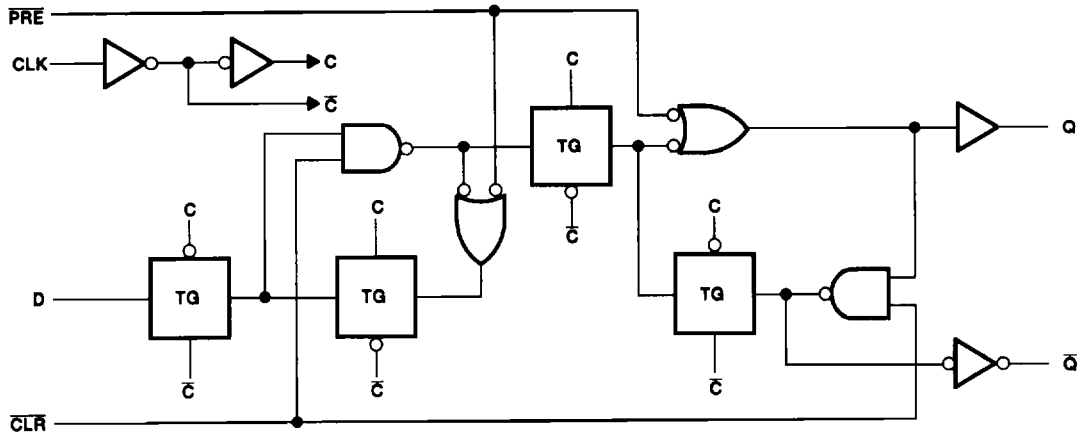

POST OFFICE BOX 655303 • DALLAS, TEXAS 75265

SN54AHCT74, SN74AHCT74 DUAL POSITIVE-EDGE-TRIGGERED D-TYPE FLIP-FLOPS WITH CLEAR AND PRESET

SCLS2638 - DECEMBER 1995 - REVISED JULY 1996

absolute maximum ratings over operating free-air temperature range (unless otherwise noted)†

Supply voltage range, V_{CC}	-0.5 V to 7 V
Input voltage range, V_I (see Note 1)	-0.5 V to 7 V
Output voltage range, V_O (see Note 1)	-0.5 V to 7 V
Input clamp current, I_{IK} ($V_I < 0$ or $V_I > V_{CC}$)	-20 mA
Output clamp current, I_{OK} ($V_O < 0$ or $V_O > V_{CC}$)	-20 mA
Continuous output current, I_O ($V_O = 0$ to V_{CC})	± 25 mA
Continuous current through V_{CC} or GND	± 50 mA
Maximum power dissipation at $T_A = 55^\circ\text{C}$ (in still air) (see Note 2): D package	1.25 W
DB or PW package	0.5 W
N package	1.1 W
Storage temperature range, T_{stg}	-65°C to 150°C

† Stresses beyond those listed under "absolute maximum ratings" may cause permanent damage to the device. These are stress ratings only, and functional operation of the device at these or any other conditions beyond those indicated under "recommended operating conditions" is not implied. Exposure to absolute-maximum-rated conditions for extended periods may affect device reliability.

- NOTES: 1. The input and output voltage ratings may be exceeded if the input and output current ratings are observed.
 2. The maximum package power dissipation is calculated using a junction temperature of 150°C and a board trace length of 750 mils, except for the N package, which has a trace length of zero.

recommended operating conditions (see Note 3)

		SN54AHCT74		SN74AHCT74		UNIT
		MIN	MAX	MIN	MAX	
V_{CC}	Supply voltage	4.5	5.5	4.5	5.5	V
V_{IH}	High-level input voltage	2		2		V
V_{IL}	Low-level input voltage		0.8		0.8	V
V_I	Input voltage	0	5.5	0	5.5	V
V_O	Output voltage	0	V_{CC}	0	V_{CC}	V
I_{OH}	High-level output current		-8		-8	mA
I_{OL}	Low-level output current		8		8	mA
$\Delta V/\Delta t$	Input transition rise or fall rate		20		20	ns/V
T_A	Operating free-air temperature	-55	125	-40	85	$^\circ\text{C}$

NOTE 3: Unused inputs must be held high or low to prevent them from floating.

electrical characteristics over recommended operating free-air temperature range (unless otherwise noted)

PARAMETER	TEST CONDITIONS	V_{CC}	$T_A = 25^\circ\text{C}$			SN54AHCT74		SN74AHCT74		UNIT
			MIN	TYP	MAX	MIN	MAX	MIN	MAX	
V_{OH}	$I_{OH} = -50 \mu\text{A}$	4.5 V	3.15	3.65		3.15			V	
	$I_{OH} = -8 \text{ mA}$				2.5		2.4			
V_{OL}	$I_{OL} = 50 \mu\text{A}$	4.5 V			0.1		0.1	0.1	V	
	$I_{OL} = 8 \text{ mA}$				0.36		0.5	0.44		
I_I	$V_I = V_{CC}$ or GND	5.5 V			± 0.1		± 1	± 1	μA	
I_{CC}	$V_I = V_{CC}$ or GND, $I_O = 0$	5.5 V			2		20	20	μA	
ΔI_{CC}^\ddagger	One input at 3.4 V, Other inputs at GND or V_{CC}	5.5 V			1.35		1.5	1.5	mA	
I_{off}	$V_O = 5.5 \text{ V}$	0 V			0.5*			5	μA	
C_i	$V_I = V_{CC}$ or GND	5 V			2	10		10	pF	

* On products compliant to MIL-PRF-38535, this parameter does not apply.

‡ This is the increase in supply current for each input at one of the specified TTL voltage levels rather than 0 V or V_{CC} .



POST OFFICE BOX 655303 • DALLAS, TEXAS 75265

SN54AHCT74, SN74AHCT74
DUAL POSITIVE-EDGE-TRIGGERED D-TYPE FLIP-FLOPS
WITH CLEAR AND PRESET

SCLS263B – DECEMBER 1995 – REVISED JULY 1996

timing requirements over recommended ranges of supply voltage and operating free-air temperature (unless otherwise noted) (see Figure 1)

PARAMETER		T _A = 25°C		SN54AHCT74		SN74AHCT74		UNIT
		MIN	MAX	MIN	MAX	MIN	MAX	
t _w	Pulse duration	PRE or CLR low	5	5	5	5	5	ns
		CLK	5	5	5	5		
t _{su}	Setup time before CLK↑	Data	5	5	5	5	5	ns
		PRE or CLR inactive	3.5	3.5	3.5	3.5		
t _h	Hold time, data after CLK↑	0	0	0	0	0	0	ns

switching characteristics over recommended ranges of supply voltage and operating free-air temperature (unless otherwise noted) (see Figure 1)

PARAMETER	FROM (INPUT)	TO (OUTPUT)	LOAD CAPACITANCE	SN54AHCT74				UNIT	
				T _A = 25°C			MIN		MAX
				MIN	TYP	MAX			
f _{max}			C _L = 15 pF	100	160		80	MHz	
			C _L = 50 pF	80	140		65		
t _{PLH} *	PRE or CLR	Q or Q̄	C _L = 15 pF	7.6	10.4	1	12	ns	
t _{PHL} *				7.6	10.4	1	12		
t _{PLH} *	CLK	Q or Q̄	C _L = 15 pF	5.8	7.8	1	9	ns	
t _{PHL} *				5.8	7.8	1	9		
t _{PLH}	PRE or CLR	Q or Q̄	C _L = 50 pF	8.1	11.4	1	13	ns	
t _{PHL}				8.1	11.4	1	13		
t _{PLH}	CLK	Q or Q̄	C _L = 50 pF	6.3	8.8	1	10	ns	
t _{PHL}				6.3	8.8	1	10		

* On products compliant to MIL-PRF-38535, this parameter is ensured but not production tested.

switching characteristics over recommended ranges of supply voltage and operating free-air temperature (unless otherwise noted) (see Figure 1)

PARAMETER	FROM (INPUT)	TO (OUTPUT)	LOAD CAPACITANCE	SN74AHCT74				UNIT	
				T _A = 25°C			MIN		MAX
				MIN	TYP	MAX			
f _{max}			C _L = 15 pF	100	160		80	MHz	
			C _L = 50 pF	80	140		65		
t _{PLH}	PRE or CLR	Q or Q̄	C _L = 15 pF	7.6	10.4	1	12	ns	
t _{PHL}				7.6	10.4	1	12		
t _{PLH}	CLK	Q or Q̄	C _L = 15 pF	5.8	7.8	1	9	ns	
t _{PHL}				5.8	7.8	1	9		
t _{PLH}	PRE or CLR	Q or Q̄	C _L = 50 pF	8.1	11.4	1	13	ns	
t _{PHL}				8.1	11.4	1	13		
t _{PLH}	CLK	Q or Q̄	C _L = 50 pF	6.3	8.8	1	10	ns	
t _{PHL}				6.3	8.8	1	10		



POST OFFICE BOX 655303 • DALLAS, TEXAS 75265

SN54AHCT74, SN74AHCT74 DUAL POSITIVE-EDGE-TRIGGERED D-TYPE FLIP-FLOPS WITH CLEAR AND PRESET

SCLS263B – DECEMBER 1995 – REVISED JULY 1996

noise characteristics, $V_{CC} = 5\text{ V}$, $C_L = 50\text{ pF}$, $T_A = 25^\circ\text{C}$ (see Note 4)

PARAMETER	SN74AHCT74		UNIT
	MIN	MAX	
$V_{OL(P)}$ Quiet output, maximum dynamic V_{OL}	0.8		V
$V_{OL(V)}$ Quiet output, minimum dynamic V_{OL}	-0.8		V
$V_{OH(V)}$ Quiet output, minimum dynamic V_{OH}	4		V
$V_{IH(D)}$ High-level dynamic input voltage	2		V
$V_{IL(D)}$ Low-level dynamic input voltage	0.8		V

NOTE 4: Characteristics are determined during product characterization and ensured by design for surface-mount packages only.

operating characteristics, $V_{CC} = 5\text{ V}$, $T_A = 25^\circ\text{C}$

PARAMETER	TEST CONDITIONS	TYP	UNIT
C_{pd} Power dissipation capacitance	No load, $f = 1\text{ MHz}$	32	pF

PARAMETER MEASUREMENT INFORMATION

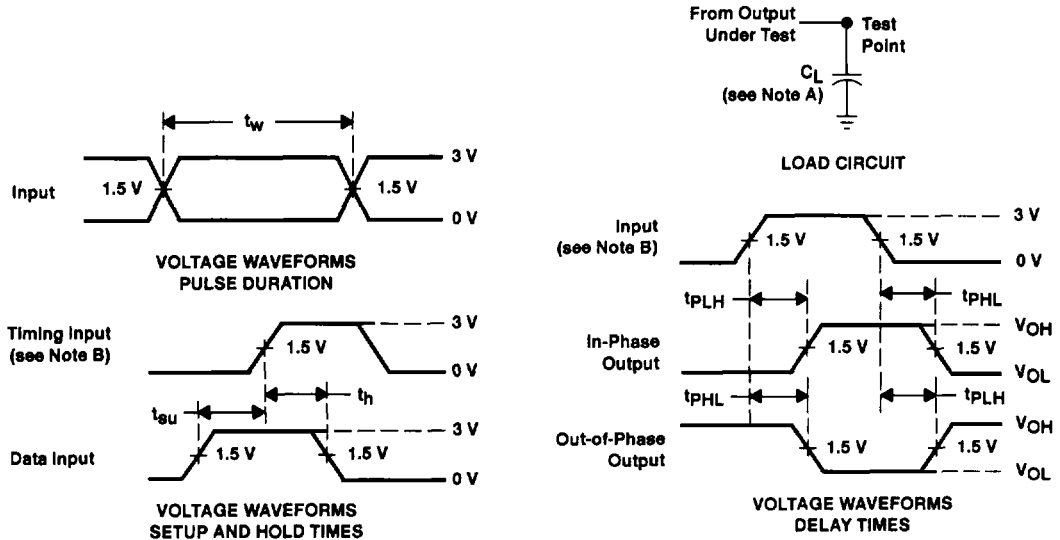

- NOTES: A. C_L includes probe and jig capacitance.
 B. All input pulses are supplied by generators having the following characteristics: $PRR \leq 1\text{ MHz}$, $Z_O = 50\ \Omega$, $t_r = 3\text{ ns}$, $t_f = 3\text{ ns}$.
 C. The outputs are measured one at a time with one input transition per measurement.

Figure 1. Load Circuit and Voltage Waveforms