

## Quad, 12-Bit, Voltage Output D/A Converter

- Four 12-Bit DAC's on a Single Chip
- Low Power — 80 mW (20mW/DAC)
- Double-Buffered Inputs
- Voltage Outputs
- Midscale Preset, Zero Volts Out
- 1MHz 4-Quadrant Multiplying Bandwidth
- 28-pin PLCC, SOIC and Plastic DIP Packages
- 28-pin Ceramic Side-Braced Package for Extended Temperature Range (-55°C to +125°C)

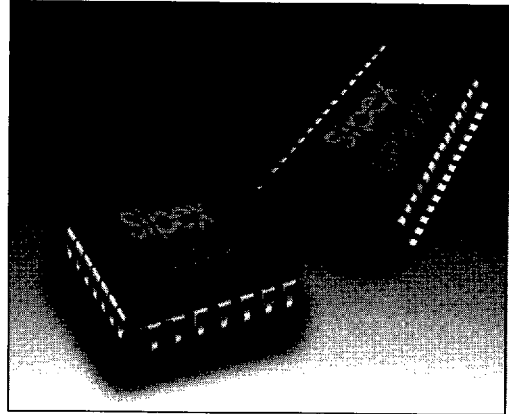

### DESCRIPTION...

The **SP9504** is a low power replacement for the popular SP9345, Quad 12-Bit Digital-to-Analog Converter. It features  $\pm 4.5V$  output swings when using  $\pm 5V$  supplies. The converter is double-buffered for easy microprocessor interface. Each 12-bit DAC is independently addressable and may be simultaneously updated using a single transfer command. The output settling-time is specified at  $4\mu s$ . The **SP9504** is available in 28-pin SOIC, PLCC and plastic DIP packages, specified over commercial and industrial temperature ranges. A ceramic side-braced package is available for extended (-55°C to +125°C) temperature range applications.

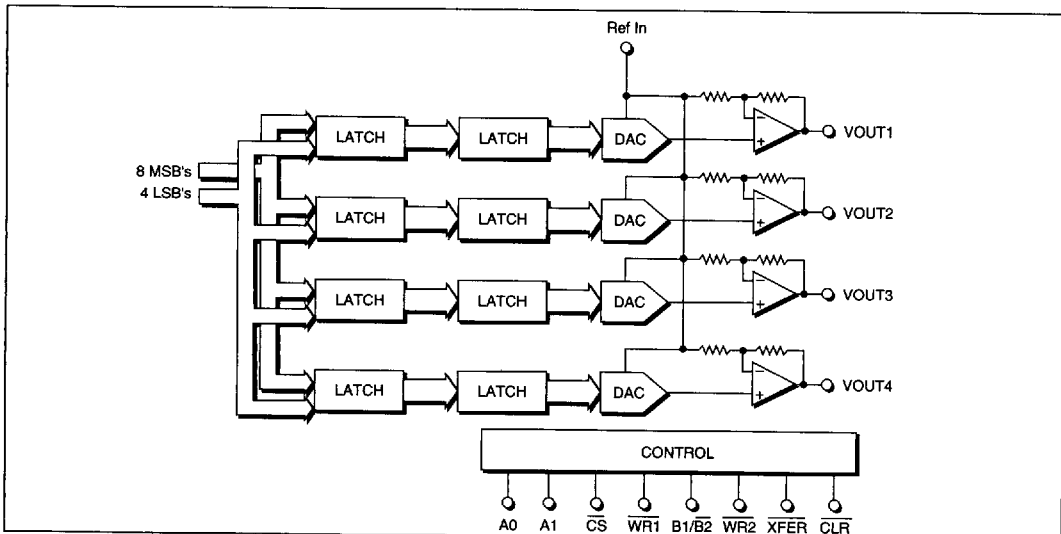

# ABSOLUTE MAXIMUM RATINGS

These are stress ratings only and functional operation of the device at these or any other above those indicated in the operation sections of the specifications below is not implied. Exposure to absolute maximum rating conditions for extended periods of time may affect reliability.

$V_{DD} - GND$ .....	-0.3V, +6.0V
$V_{SS} - GND$ .....	+0.3V, -6.0V
$V_{DD} - V_{SS}$ .....	-0.3V, +12.0V
$V_{REF}$ .....	$V_{SS}^1, V_{DD}$
$D_{IN}$ .....	$V_{SS}^1, V_{DD}$
Power Dissipation .....	375mW
Plastic DIP .....	375mW
(derate 7mW/°C above +70°C)	
Plastic LCC .....	375mW
(derate 7mW/°C above +70°C)	
Small Outline .....	375mW
(derate 7mW/°C above +70°C)	
Ceramic Side-Brazed .....	6JC 20°C/W

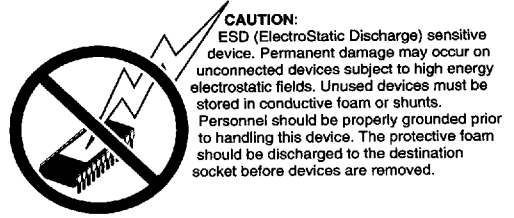

# SPECIFICATIONS

(Typical at 25°C;  $T_{MIN} \leq T_A \leq T_{MAX}$ ;  $V_{DD} = +5V, V_{SS} = -5V, V_{REF} = +3V$ ; CMOS logic level digital inputs; specifications apply to all grades unless otherwise noted.)

PARAMETER	MIN.	TYP.	MAX.	UNITS	CONDITIONS
<b>DIGITAL INPUTS</b>					
Logic Levels					
$V_{IH}$	2.4		0.8	Volts	
$V_{IL}$				Volts	
4 Quad, Bipolar Coding		Offset Binary			
<b>REFERENCE INPUT</b>					
Voltage Range		±3	±4.5	Volts	
Input Resistance	1.5	2.2		kΩ	$D_{IN} = 1,877$ ; code dependent
<b>SWITCHING CHARACTERISTICS</b>					
Strobe Width	120			ns	
Data Set-up Time	125			ns	
Data Hold Time	0			ns	
<b>ANALOG OUTPUT</b>					
Gain					
-B, -K		±0.5	±2.0	LSB	$V_{REF} = ±3V$ ; Note 3
-T		±0.5	±4.0	LSB	$V_{REF} = ±3V$ ; Note 3
-A, -J		±1.0	±4.0	LSB	$V_{REF} = ±3V$ ; Note 3
-S		±1.0	±6.0	LSB	$V_{REF} = ±3V$ ; Note 3
-B, -K, -A, -J		±1.0	±5.0	LSB	$V_{REF} = ±4.5V$ ; Note 3
Initial Offset Bipolar		±0.25	±3.0	LSB	$D_{IN} = 2,048$
Voltage Range Bipolar		±3.0	±4.5	Volts	
Output Current	±5.0			mA	$V_{REF} = ±3V$
	±0.5			mA	$V_{REF} = ±4.5V$
<b>STATIC PERFORMANCE</b>					
Resolution	12			Bits	
Integral Linearity					
-B, -K		±0.25	±0.5	LSB	$V_{REF} = ±3V$ ; Note 3
-T		±0.25	±0.80	LSB	$V_{REF} = ±3V$ ; Note 3
-A, -J		±0.5	±1.0	LSB	$V_{REF} = ±3V$ ; Note 3
-S		±0.5	±1.0	LSB	$V_{REF} = ±3V$ ; Note 3
-B, -K, -A, -J		±0.5	±3.0	LSB	$V_{REF} = ±4.5V$ ; Note 3
Differential Linearity					
-B, -K, -T		±0.25	±0.75	LSB	
-A, -J, -S		±0.25	±1.0	LSB	
Monotonicity		Guaranteed			

## SPECIFICATIONS (continued)

(Typical at 25°C;  $T_{MIN} \leq T_A \leq T_{MAX}$ ;  $V_{DD} = +5V$ ,  $V_{SS} = -5V$ ,  $V_{REF} = +3V$ ; CMOS logic level digital inputs; specifications apply to all grades unless otherwise noted.)

PARAMETER	MIN.	TYP.	MAX.	UNITS	CONDITIONS
<b>DYNAMIC PERFORMANCE</b>					
Settling Time					
Small Signal		0.5		$\mu s$	to 0.012%
Full Scale		4		$\mu s$	to 0.012%
Slew Rate		4		V/ $\mu s$	
<b>STABILITY</b>					
Gain		15		ppm/°C	$t_{MIN}$ to $t_{MAX}$
Bipolar Zero		15		ppm/°C	$t_{MIN}$ to $t_{MAX}$
<b>POWER REQUIREMENTS</b>					
$V_{DD}$					+5V, $\pm 3\%$ ; Note 4
-J, -K		8	11	mA	
-A, -B		8	15	mA	
-S, -T		8	17	mA	
$V_{SS}$					-5V, $\pm 3\%$ ; Note 4
-J, -K		8	11	mA	
-A, -B		8	15	mA	
-S, -T		8	17	mA	
Power Dissipation		80		mW	
<b>ENVIRONMENTAL AND MECHANICAL</b>					
Operating Temperature					
-J, -K	0		+70	°C	
-A, -B	-40		+85	°C	
-S, -T	-55		+125	°C	
Storage	-60		+150	°C	
Package					
-P		28-pin Plastic DIP			
-L		28-pin Plastic LCC			
-S		28-pin SOIC			
-Q		28-pin Ceramic Side-Brazed			

### Notes:

1. Integral Linearity, for the **SP9504**, is measured as the arithmetic mean value of the magnitudes of the greatest positive deviation and the greatest negative deviation from the theoretical value for any given input condition.
2. Differential Linearity is the deviation of an output step from the theoretical value of 1 LSB for any two adjacent digital input codes.
3.  $1 \text{ LSB} = 2^*V_{REF}/4,096$ .
4.  $V_{REF} = 0V$ .

## PINOUT — 28-PIN PLASTIC LCC

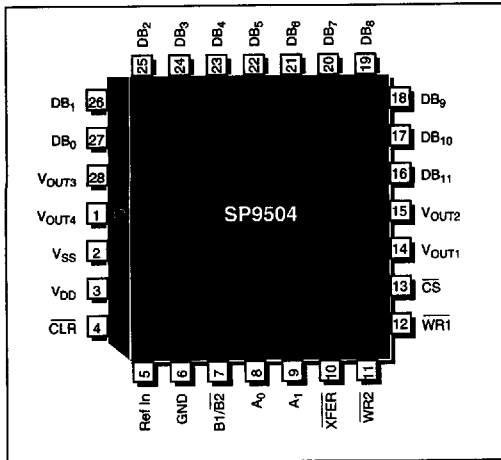

## PINOUT — 28-PIN PLASTIC DIP & SOIC

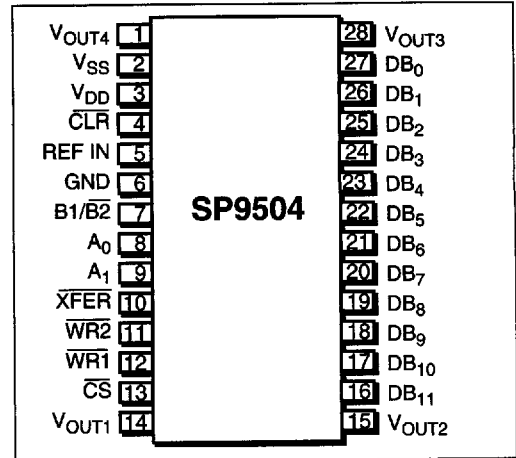

### PIN ASSIGNMENTS

Pin 1 —  $V_{OUT4}$  — Voltage Output from DAC4.

Pin 2 —  $V_{SS}$  — -5V Power Supply Input.

Pin 3 —  $V_{DD}$  — +5V Power Supply Input.

Pin 4 —  $\overline{CLR}$  — Clear. Gated with  $\overline{XFER}$  (pin 10). Active low. Clears all DAC outputs to 0V.

Pin 5 — REF IN — Reference Input for DACs.

Pin 6 — GND — Ground.

Pin 7 —  $B1/\overline{B2}$  — Byte 1/Byte 2 — Selects Data Input Format. A logic "1" on pin 7 selects the 12-bit mode, and all 12 data bits are presented to the DAC(s) unchanged; a logic "0" selects the 8-bit mode, and the four LSBs are connected to the four MSBs, allowing an 8-bit MSB-justified interface.

Pins 8 and 9 —  $A_0$  &  $A_1$  — Address for DAC Selection.  $A_0/A_1 = 0/0 = \text{DAC1}$ ;  $0/1 = \text{DAC2}$ ;  $1/0 = \text{DAC3}$ ;  $1/1 = \text{DAC4}$ .

Pin 10 —  $\overline{XFER}$  — Transfer. Gated with  $\overline{WR2}$  (pin 11); loads all DAC registers simultaneously. Active low.

Pin 11 —  $\overline{WR2}$  — Write Input 2 — In conjunction with  $\overline{XFER}$  (pin 10), controls the transfer of data from the first set of latches to the second. In conjunction with  $\overline{CLR}$  (pin 4), the second latch is reset to all 0's, and the DAC outputs will settle to 0V output.

Pin 12 —  $\overline{WR1}$  — Write Input 1 — In conjunction with Chip Select (pin 13), enables DAC selection, and controls the transfer of data from the input bus to the first set of latches.

Pin 13 —  $\overline{CS}$  — Chip Select — Enables writing data to input latches and/or transferring data from input to secondary latches, and DAC(s).

Pin 14 —  $V_{OUT1}$  — Voltage Output from DAC1.

Pin 15 —  $V_{OUT2}$  — Voltage Output from DAC2.

Pin 16 —  $DB_{11}$  — Data Bit 11; Most Significant Bit.

Pin 17 —  $DB_{10}$  — Data Bit 10.

Pin 18 —  $DB_9$  — Data Bit 9.

Pin 19 —  $DB_8$  — Data Bit 8.

Pin 20 —  $DB_7$  — Data Bit 7.

Pin 21 —  $DB_6$  — Data Bit 6.

Pin 22 —  $DB_5$  — Data Bit 5.

Pin 23 —  $DB_4$  — Data Bit 4.

Pin 24 —  $DB_3$  — Data Bit 3.

Pin 25 —  $DB_2$  — Data Bit 2.

Pin 26 —  $DB_1$  — Data Bit 1.

Pin 27 —  $DB_0$  — Data Bit 0.

Pin 28 —  $V_{OUT3}$  — Voltage Output from DAC3.

## FEATURES...

The **SP9504** is a low-power replacement the popular SP9345, Quad 12-Bit Digital-to-Analog Converter. This Quad, Voltage Output, 12-Bit Digital-to-Analog Converter features  $\pm 4.5V$  output swings when using  $\pm 5V$  supplies. The input coding format used is standard offset binary.

The converter utilizes double-buffering on each of the 12 parallel digital inputs, for easy microprocessor interface. Each 12-bit DAC is independently addressable and may be simultaneously updated using a single  $\overline{XFER}$  command. The output settling-time is specified at  $4\mu s$  to full 12-bit accuracy when driving a 5Kohm, 50pF load combination. The **SP9504**, Quad 12-Bit Digital-to-Analog Converter is ideally suited for applications such as ATE, process controllers, robotics, and instrumentation. The **SP9504** is available in 28-pin plastic leadless chip carrier (PLCC), plastic DIP or SOIC packages, specified over the commercial ( $0^{\circ}C$  to  $+70^{\circ}C$ ) and industrial ( $-40^{\circ}C$  to  $+85^{\circ}C$ ) temperature ranges. A ceramic side-brazed package is available for extended ( $-55^{\circ}C$  to  $+125^{\circ}C$ ) applications.

## THEORY OF OPERATION

The **SP9504** consists of five main functional blocks — input data multiplexer, DAC registers, control logic, four 12-bit D/A converters, and four bipolar output voltage amplifiers. The input data multiplexer is designed to interface to either 12- or 8-bit microprocessor data busses. The data selection (width) accepted by the **SP9504** is controlled by the B1/B2 signal — a logic "1" selects the 12-bit mode, while a logic "0" selects the 8-bit mode. In the 12-bit mode the data is transferred to the DAC registers without changes in its format. In the 8-bit mode, the four least

significant bits (LSBs) are connected to the four most significant bits (MSBs), allowing an 8-bit MSB-justified interface. All data inputs are enabled using the  $\overline{CS}$  signal in both modes. The digital inputs are designed to be both TTL and 5V CMOS compatible.

In order to reduce the DAC full scale output sensitivity to the large weighting of the MSB's found in conventional R-2R resistor ladders, the 3 MSB's are decoded into 8 equally weighted levels. This reduces the contribution of each bit by a factor of 4, thus, reducing the output sensitivity to mismatches in resistors and switches by the same amount. Linearity errors and stability are both improved for the same reasons.

Each D/A converter is separated from the data bus by two sets of registers, each consisting of level-triggered latches. The first set is the input register and is 12-bits wide. This register is selected by the address input  $A_0$  and  $A_1$ , and is enabled by the  $\overline{CS}$  and  $\overline{WR1}$  signals. In the 8-bit mode, the enable signal to the 8 MSB's is disabled by a logic low on B1/B2 to allow the 4 LSB's to be updated. The second register, which accepts the decoded 3 MSB's plus the 9 LSB's, is 16-bits wide. The four secondary registers are updated simultaneously for all DAC's using the  $\overline{XFER}$  and  $\overline{WR2}$  signals. Using the  $\overline{CLR}$  and  $\overline{WR2}$  signals or the power-on-reset, (enabled when the power is switched on) the second register is set to all 0's and the DAC output will settle to 0V.

Using the control logic block inputs, the user has full control of address decoding, chip enable, data transfer and clearing of the DAC's. The logic inputs are level triggered, and like the digital code inputs, are TTL and CMOS compatible. The truth table (Table 2) shows the appropriate functions associated with the states of the inputs.

The DACs themselves are implemented with a precision thin-film resistor network and CMOS transmission gate switches. Each D/A converter is used to convert the 12-bit input from the second storage register to a precision voltage.

The bipolar voltage output of the **SP9504** is created on-chip from the DAC Voltage Output ( $V_{DAC}$ ) by using an operational amplifier and two feedback resistors connected as shown in Figure 2. This configuration produces a  $\pm 4.5V$  bipolar output with standard offset binary coding.

INPUT			OUTPUT
MSB	LSB		
1111	1111	1111	$V_{REF} - 1 \text{ LSB}$
1111	1111	1110	$V_{REF} - 2 \text{ LSB}$
1000	0000	0001	$0 + 1 \text{ LSB}$
1000	0000	0000	0
0000	0000	0001	$0 + 1 \text{ LSB}$
0000	0000	0000	$-V_{REF}$
$1 \text{ LSB} = \frac{2V_{REF}}{2^{12}}$			

Table 1. Offset Binary Coding

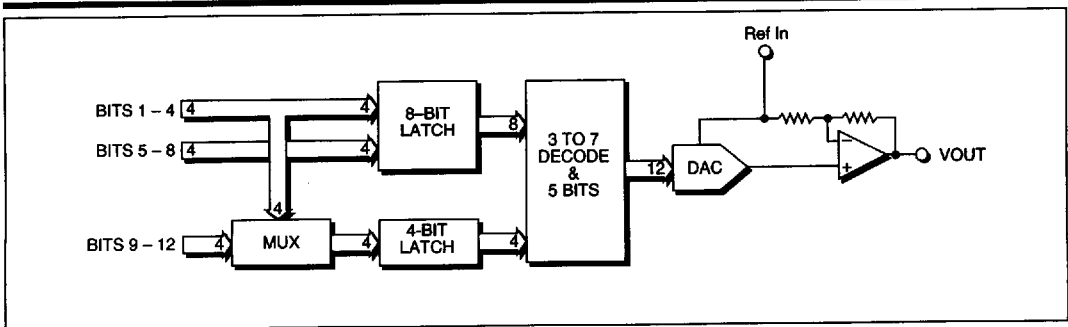

Figure 1. Detailed Block Diagram (only one DAC shown)

## USING THE SP9504

### Loading Data

The sequence necessary to load a 12-bit word on a 12-bit wide data bus is as follows:

- 1) Set  $\overline{XFER}=1$ ,  $B1/\overline{B2}=1$ ,  $\overline{CLR}=1$ ,  $\overline{WR1}=1$ ,  $\overline{WR2}=1$ ,  $\overline{CS}=1$ .
- 2) Set  $A_0$  and  $A_1$  (the DAC address) to the desired DAC—0,0 = DAC<sub>1</sub>; 0,1 = DAC<sub>2</sub>; 1,0 = DAC<sub>3</sub>; 1,1 = DAC<sub>4</sub>.
- 3) Set D11 (MSB) through D0 (LSB) to the desired digital input code.
- 4) Load the word to the selected DAC by cycling  $\overline{WR1}$  and  $\overline{CS}$  through the following sequence:  
"1" — "0" — "1"
- 5) Repeat sequence for each register.

To load a 12-bit word to the input register of each DAC, using an 8-bit data bus, the sequence is as follows:

- 1) Set  $\overline{XFER}=1$ ,  $B1/\overline{B2}=1$ ,  $\overline{CLR}=1$ ,  $\overline{WR1}=1$ ,  $\overline{WR2}=1$ ,  $\overline{CS}=1$ .
- 2) Set D11 through D4 to the 8 MSB's of the desired digital input code.
- 3) Load the 8 MSB's of the digital word to the selected input register by cycling  $\overline{WR1}$  and  $\overline{CS}$  through the "1" — "0" — "1" sequence.
- 4) Reset  $B1/\overline{B2}$  from "1" — "0"
- 5) Set D11 (MSB) through D8 to the 4 LSB's of the digital input code.
- 6) Load the 4 LSB's by cycling  $\overline{WR1}$  and  $\overline{CS}$  through the "1" — "0" — "1" sequence.

$A_1$	$A_0$	$\overline{CS}$	$\overline{WR1}$	$B1/\overline{B2}$	$\overline{WR2}$	$\overline{XFER}$	$\overline{CLR}$	FUNCTION
0	0	0	0	1	1	X	X	Address DAC 1 and load input register
0	0	0	0	0	1	X	X	Address DAC 1 and load 4 LSBs
0	1	0	0	1	1	X	X	Address DAC 2 and load input register
0	1	0	0	0	1	X	X	Address DAC 2 and load 4 LSBs
1	0	0	0	1	1	X	X	Address DAC 3 and load input register
1	0	0	0	0	1	X	X	Address DAC 3 and load 4 LSBs
1	1	0	0	1	1	X	X	Address DAC 4 and load input register
1	1	0	0	0	1	X	X	Address DAC 4 and load 4 LSBs
X	0	**	**	X	0	0	1	Transfer data from input register to DACs
X	X	X	X	X	0	X	0	Clears all DAC output voltages to 0V
X	X	1	X	X	X	X	X	Invalid state with any other control line active
X	X	X	1	X	X	X	X	Invalid state with any other control line active

X = Don't care; \*\* = Don't care; however,  $\overline{CS}$  and  $\overline{WR1} = 1$  will inhibit changes to the input registers.

Table 2. Control Truth Table

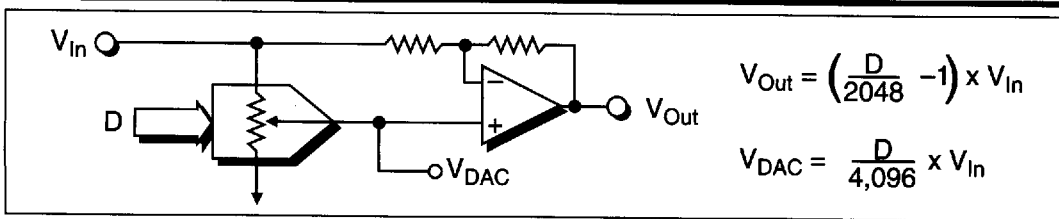

Figure 2. Transfer Function

To transfer the four 12-bit words in the four input registers to the DAC registers:

- 1) Set  $\overline{\text{CLR}}=1$ ,  $\overline{\text{CS}}=1$ ,  $\overline{\text{WR1}}=1$ .
- 2) Cycle  $\overline{\text{WR2}}$  and  $\overline{\text{XFER}}$  through the "1" — "0" — "1" sequence.

To "zero" the outputs of the two DAC's, cycle  $\overline{\text{WR2}}$  and  $\overline{\text{CLR}}$  through the "1" — "0" — "1" sequence.

### Two Latches, One Latch, or No Latches

The latches can be used in a "semi-transparent" mode, and a "fully-transparent" mode. In order to use the **SP9504** in either mode the user must be interfaced to a 12-bit bus only.

The semi-transparent mode is set up such that the first set of latches is transparent and the second set is used to latch the incoming data. Data is latched into the second set rather than the first set, in order to minimize glitch energy induced from the data formatting. In this mode,  $\overline{\text{WR1}}$  and  $\overline{\text{CS}}$  are tied low, and  $\overline{\text{WR2}}$  and  $\overline{\text{XFER}}$  are used to strobe the data to the DAC's. Each DAC is addressed using the address lines  $A_0$  and  $A_1$ . After the appropriate DAC has been selected and the data is settled at the digital inputs, bringing  $\overline{\text{WR2}}$  and  $\overline{\text{XFER}}$  low will transfer the data to the DAC's. The user should be sure to bring  $\overline{\text{XFER}}$  and  $\overline{\text{WR2}}$  high again so that the next selected DAC will not be overwritten by the last digital code. By strobing  $\overline{\text{XFER}}$  and  $\overline{\text{WR2}}$ , all DAC's will be updated simultaneously. This mode of operation may be useful in applications where preloading of the input registers is not necessary.

A fully transparent mode is realized by typing  $\overline{\text{WR1}}$ ,  $\overline{\text{CS}}$ ,  $\overline{\text{WR2}}$ , and  $\overline{\text{XFER}}$  all low. In this mode, anything that is written on the 12-bit data

bus will be passed directly to the selected DAC. Since both latches are not being used, the previous digital word will be overwritten by the new data as soon as the address changes and the data bus is switched to the appropriate DAC. This may be useful should the user want to calibrate a circuit, by taking full scale or zero scale readings for all four DAC's.

### Zeroing DAC Outputs

The DAC outputs can be set to zero volts two different ways. The first involves the  $\overline{\text{CLR}}$  and  $\overline{\text{WR2}}$  pins. In normal operation, the  $\overline{\text{CLR}}$  pin is tied high, thus, disabling the clear function. When this pin is brought low with  $\overline{\text{WR2}}$ , a digital code of 1000 0000 0000 is written to all four DAC inputs, producing a half scale output or zero volts. When the  $\overline{\text{CLR}}$  pin is brought back high, the digital code at the second register will again appear at the DAC digital input, and the analog output will return to its previous corresponding value. The second utilizes the built in power-on-reset. Using this feature, the **SP9504** can be configured such that during power-up, the second latch will be digitally "zeroed", producing a zero volt output at each of the four DAC outputs. This is achieved by powering the unit up with  $\overline{\text{XFER}}$  in a high state. Thus, with no external circuitry, the **SP9504** can be powered up with the analog outputs at a known, zero volt output level.

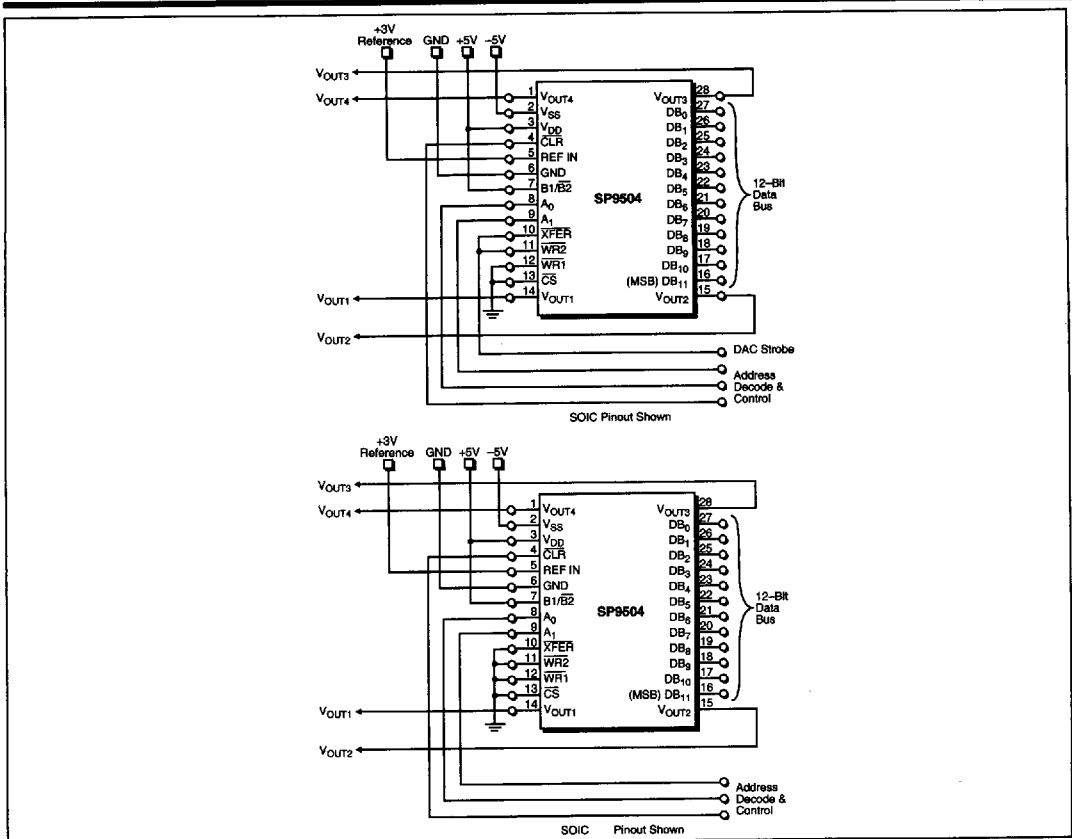

Figure 3. Latch Control Options — (Top) Semi-Transparent Latch Mode; (Bottom) Fully-Transparent Latch Mode

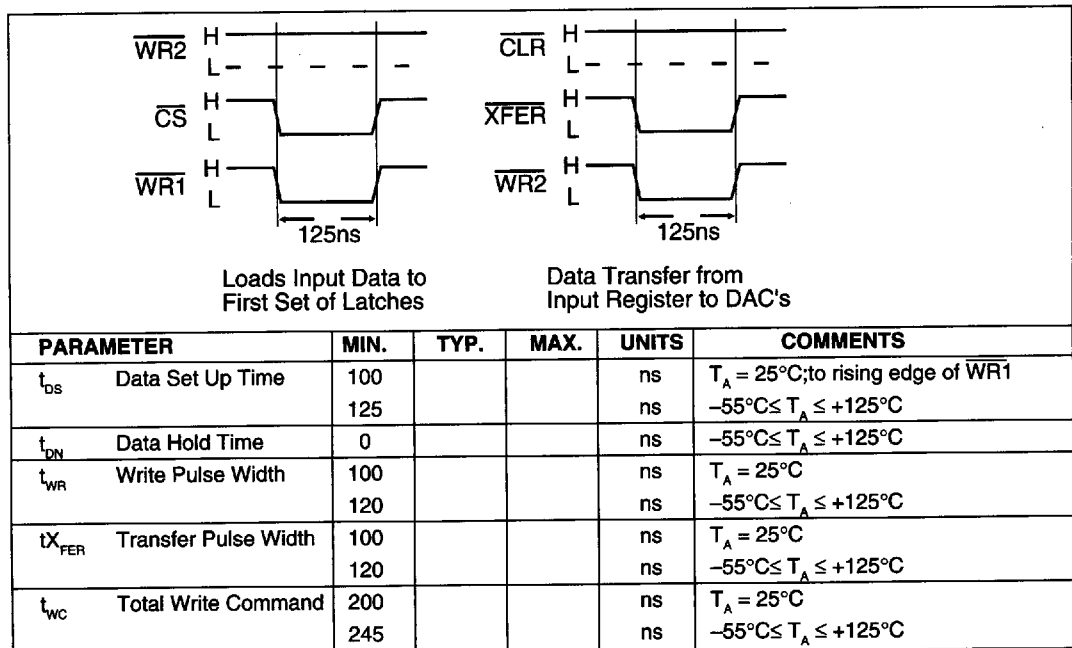

Figure 4. Timing



## ORDERING INFORMATION

Model	Temperature Range	Package
Monolithic 12-Bit Quad DAC Voltage Output:		
SP9504JL*	0°C to +70°C	28-pin PLCC
SP9504KL*	0°C to +70°C	28-pin PLCC
SP9504JP	0°C to +70°C	28-pin, 0.6" Plastic DIP
SP9504KP	0°C to +70°C	28-pin, 0.6" Plastic DIP
SP9504JS	0°C to +70°C	28-pin, 0.4" SOIC
SP9504KS	0°C to +70°C	28-pin, 0.4" SOIC
SP9504AL*	-40°C to +85°C	28-pin PLCC
SP9504BL*	-40°C to +85°C	28-pin PLCC
SP9504AP	-40°C to +85°C	28-pin, 0.6" Plastic DIP
SP9504BP	-40°C to +85°C	28-pin, 0.6" Plastic DIP
SP9504AS	-40°C to +85°C	28-pin, 0.4" SOIC
SP9504BS	-40°C to +85°C	28-pin, 0.4" SOIC
SP9504SQ*	-55°C to +125°C	28-pin, 0.6" Ceramic Side-Brazed
SP9504TQ*	-55°C to +125°C	28-pin, 0.6" Ceramic Side-Brazed

\*Consult Factory