

**Header Assemblies, Shrouded
Polarized/Latching, Single Row
.100 [2.54] Centers**
(Continued)

**.025 [0.64] Square
Right Angle Post**

Material and Finish:

Housing—Black thermoplastic, 94V-0 rated

Contacts—Copper alloy, plated tin or gold duplex

Related Product Data:

Mateable AMPMODU MTE

Products:

Receptacle Assemblies (Polarized/Latching)—pages 6 and 7

Receptacle Assemblies with Guide Ribs (Installed in Single Row Coupling Shroud)—pages 8, 9 and 14

Technical Documents—page 25

With Hold Down

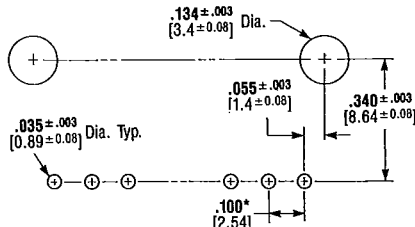
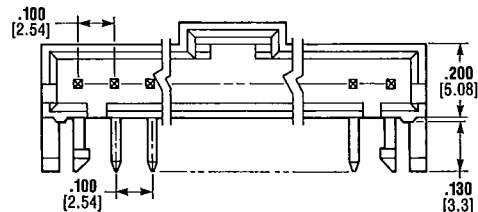
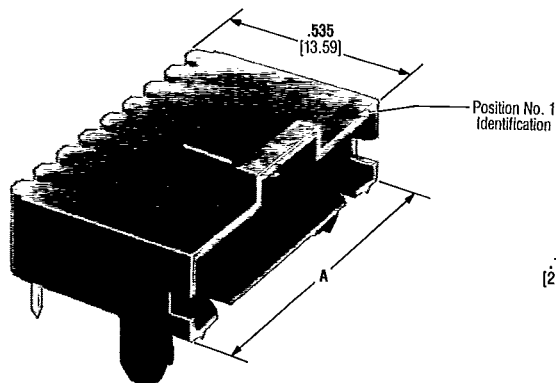

Recommended Pc Board Hole Layout

Pc board thickness (for Hold Down Feature) is $.062 \pm .008$ [1.57 ± 0.2]

*Post centerline tolerance is $\pm .003$ [± 0.08]; tolerance not to accumulate within one connector pattern.

Without Hold Down

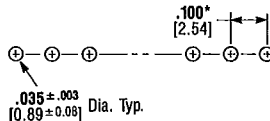
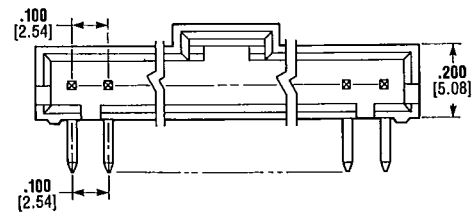
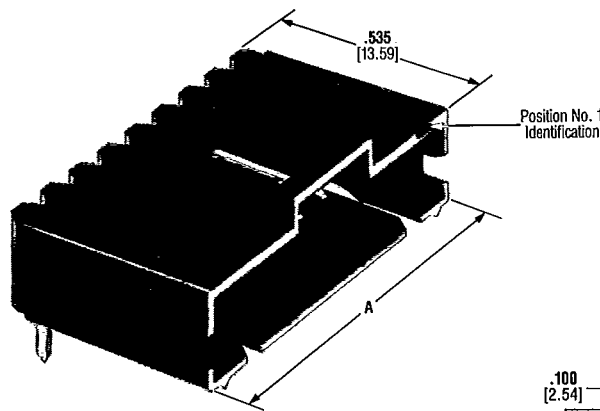

Recommended Pc Board Hole Layout

*Post centerline tolerance is $\pm .003$ [± 0.08]; tolerance not to accumulate within one connector pattern.

For drawings, technical data or samples, contact your AMP sales engineer or call the AMP Product Information Center 1-800-522-6752.

Dimensioning:
 Dimensions are in inches and millimeters.
 Values in brackets are metric equivalents.
 Chart contains dimensions in inches over
 millimeters.
 Dimensions are for reference purposes only.

Individual Assemblies

No. of Pos.	Dimension A	Unit Package Order Quantities	Header Assembly With Hold Down			Header Assembly Without Hold Down		
			Tin Plating ¹	Duplex Plating ²	Duplex Plating ³	Tin Plating ¹	Duplex Plating ²	Duplex Plating ³
2	.300 7.62	284	103672-1	103673-1	103904-1	103634-1	103635-1	103906-1
3	.400 10.16	212	103672-2	103673-2	103904-2	103634-2	103635-2	103906-2
4	.500 12.7	172	103672-3	103673-3	103904-3	103634-3	103635-3	103906-3
5	.600 15.24	140	103672-4	103673-4	103904-4	103634-4	103635-4	103906-4
6	.700 17.78	120	103672-5	103673-5	103904-5	103634-5	103635-5	103906-5
7	.800 20.32	104	103672-6	103673-6	103904-6	103634-6	103635-6	103906-6
8	.900 22.86	92	103672-7	103673-7	103904-7	103634-7	103635-7	103906-7
9	1.000 25.4	84	103672-8	103673-8	103904-8	103634-8	103635-8	103906-8
10	1.100 27.94	76	103672-9	103673-9	103904-9	103634-9	103635-9	103906-9
11	1.200 30.48	68	1-103672-0	1-103673-0	1-103904-0	1-103634-0	1-103635-0	1-103906-0
12	1.300 33.02	64	1-103672-1	1-103673-1	1-103904-1	1-103634-1	1-103635-1	1-103906-1
13	1.400 35.56	60	1-103672-2	1-103673-2	1-103904-2	1-103634-2	1-103635-2	1-103906-2
14	1.500 38.1	56	1-103672-3	1-103673-3	1-103904-3	1-103634-3	1-103635-3	1-103906-3
15	1.600 40.64	52	1-103672-4	1-103673-4	1-103904-4	1-103634-4	1-103635-4	1-103906-4
16	1.700 43.18	48	1-103672-5	1-103673-5	1-103904-5	1-103634-5	1-103635-5	1-103906-5
17	1.800 45.72	44	1-103672-6	1-103673-6	1-103904-6	1-103634-6	1-103635-6	1-103906-6
18	1.900 48.26	44	1-103672-7	1-103673-7	1-103904-7	1-103634-7	1-103635-7	1-103906-7
19	2.000 50.8	40	1-103672-8	1-103673-8	1-103904-8	1-103634-8	1-103635-8	1-103906-8
20	2.100 53.34	40	1-103672-9	1-103673-9	1-103904-9	1-103634-9	1-103635-9	1-103906-9
21	2.200 55.88	36	2-103672-0	2-103673-0	2-103904-0	2-103634-0	2-103635-0	2-103906-0
22	2.300 58.42	36	2-103672-1	2-103673-1	2-103904-1	2-103634-1	2-103635-1	2-103906-1
23	2.400 60.96	32	2-103672-2	2-103673-2	2-103904-2	2-103634-2	2-103635-2	2-103906-2
24	2.500 63.5	32	2-103672-3	2-103673-3	2-103904-3	2-103634-3	2-103635-3	2-103906-3
25	2.600 66.04	32	2-103672-4	2-103673-4	2-103904-4	2-103634-4	2-103635-4	2-103906-4

¹ .000100 [0.00254] tin-lead over .000050 [0.00127] nickel on entire contact.

² .000015 [0.00038] gold on mating area, .000050 [0.00127] min. tin-lead on termination area, with entire contact underplated .000050 [0.00127] nickel.

³ .000030 [0.00076] gold on mating area, .000050 [0.00127] min. tin-lead on termination area, with entire contact underplated .000050 [0.00127] nickel.

Note: Use Keying Tool No. 91417-1 to remove post for keying.

Performance Specifications Technical Documents and Numerical Index

Performance Specifications

Electrical Characteristics

Contact Current Rating: 3 amperes for single contact in free air
(Amperage could vary due to ambient temperature, wire size and duty cycles.)

Contact Termination Resistance: 15 milliohms (max.)

Dielectric Withstanding Voltage:

At Sea Level—600 VAC, rms

At 70,000 Ft. [21 336 m]—225 VAC, rms

Insulation Resistance: 5,000 megohms (min.)

Environmental Characteristics

Operating Temperature: -65°C to +105°C

Vibration: 15 G's

Physical Shock: 50 G's

Industrial Mixed Flow Gasing: Class 1 (20 days)

Technical Documents

Various technical documents are available for your use:

Product Specifications describe technical performance characteristics and verification tests. They are intended for the Design, Component and Quality Engineer.

108-25034 AMPMODU MTE Connectors

Application Specifications describe requirements for using the product in its intended application and/or crimping information. They are intended for the Packaging and Design Engineer and the Machine Setup Person.

114-25026 AMPMODU MTE Interconnection system

Instruction Sheets provide instructions for assembling or applying the product. They are intended for the manufacturing Assembler or Operator.

IS 6919 AMPMODU MTE Connectors

Instructional material covering operation, setup, maintenance, repair, etc. is included with each machine, tool or die set. If this material is required prior to receiving your tooling, call the AMP Customer Service hotline 1-800-722-1111 for the applicable document.

Numerical Index

Part No.	Page No.
103358	22
103634	19
103635	19
103638	17
103639	17
103640	7
103641	7
103644	7
103645	7
103648	9
103649	9
103650	9
103651	9
103652	9
103653	11
103654	13
103655	13
103656	13
103657	13
103658	11
103659	11
103660	11
103661	11
103669	17

Part No.	Page No.
103670	17
103672	19
103673	19
103680	14
103681	14
103682	15
103684	5
103685	5
103686	5
103687	5
103688	5
103734	7
103735	17
103893	11
103894	11
103895	13
103896	13
103897	7
103900	9
103901	9
103902	5
103903	5
103904	19
103906	19

Part No.	Page No.
103908	17
103944	10
103945	10
103946	10
103947	10
103948	10
103949	10
103950	12
103951	12
103952	12
103953	12
103954	12
103955	12
103956	6
103957	6
103958	6
103959	6
103960	6
103961	6
103968	8
103969	8
103970	8
103971	8
103972	8

Part No.	Page No.
103973	8
103974	4
103975	4
103976	4
103977	4
103978	4
103979	4
104257	7
104361	21
104362	21
104363	21
104438	4
104439	4
104500	14
104503	13
104505	22
104506	22
530151	22

Note: This numerical index lists all cataloged parts by base no. only. Complete part nos. (with prefixes and/ or suffixes) are shown on the page(s) indicated.

AMPMODU MTE Interconnection System

The AMPMODU MTE Interconnection System offers both wire-to-board and wire-to-wire connectors using .025 [0.64] sq. post technology.

The AMPMODU MTE Interconnection System consists of single row housings with contacts preloaded on .100 [2.54] centers. Housings are furnished with contacts partially inserted, leaving the termination areas exposed. Final contact insertion is accomplished automatically by AMP application equipment, and manually when terminated with the AMP pistol grip hand tool.

The heart of the system is the insulation displacement contact design, featured in both pin and receptacle contacts. The receptacle contact, available in either standard or high-pressure, features dual cantilever beams in an enclosed "box." The post stop prevents a mating post from disturbing the wire termination and also limits the mating depth of a long post to protect a wrap-type termination at the base of the post. The forward contact stop prevents contact overinsertion prior to termination. All contacts are furnished on carrier strips which are interlocked for stability and positive location during termination.

Single row housings are available in sizes 2 through 25 positions. Included are three styles of receptacle housings—plain, polarized/latching and ribbed and two styles of pin housings, shrouded with polarizing/latching feature and ribbed.

See pages 23 and 24 for AMP application tooling.

Table of Contents

Receptacle Assemblies, Single Row, .100 [2.54] Centers:

Plain	4-5
Polarized/Latching	6-7
With Guide Ribs	8-9

Pin Assemblies, Single Row, .100 [2.54] Centers:

Shrouded, Polarized/Latching	10-11
With Guide Ribs	12-13

Coupling Shrouds for Receptacle Assemblies with Guide Ribs:

Single Row	14
Double Row	14

Panel Mount Pin Shrouds for Pin Assemblies with Guide Ribs, Single Row 15 |

Header Assemblies, Shrouded, Single Row, .100 [2.54] Center (With or Without Hold Down):

Polarized/Latching, .025 [0.64] Sq. Straight Post	16-17
Polarized/Latching, .025 [0.64] Sq. Right-Angle Post	18-19
High-Temp, Polarized/Latching, .025 [0.64] Sq. Straight Post	20-21
High-Temp, Polarized/Latching, .025 [0.64] Sq. Right-Angle Post	20-21

Interchangeable Receptacle and Pin Contacts, Wire Crimp (Snap-In) 22 |

Application Tooling 23-24 |

Performance Specifications 25 |

Technical Documents 25 |

Numerical Index 25 |

Other AMPMODU Products 26 |

Need more information?

Call the AMP Product Information Center: 1-800-522-6752

The Product Information Center is staffed with specialists well versed in all AMP products. The Center can provide you with:

- Engineering Support
- Catalogs
- Technical Documents
- Product Samples
- AMP Authorized Distributor Locations

Dimensioning:

Dimensions are in inches and millimeters. Values in brackets are metric equivalents. Metric symbols used are:
mm² (square millimeter)
C (Celsius)
N (newton)

Note: Dimensions in this catalog are for reference purposes only. Customer drawings are available on request.

Specifications subject to change. Consult AMP Incorporated for latest design specifications.

© Copyright 1985, 1988 and 1989 by AMP Incorporated. All International Rights Reserved

AMP, AMPMODU, AMP-O-ELECTRIC, AMP-O-MATIC, CERTI-CRIMP—Trademarks of AMP Incorporated.

Product Facts

■ Receptacle assemblies mate with .025 [0.64] sq. posts; mating post length is .200 [5.08] min., .250 [6.35] max.

■ Proven AMPMODU receptacle contact design; dual cantilever beams, built-in anti-overstress, completely enclosed "box" design, standard or high-pressure

■ Insulation displacement technology

■ Two contact sizes for terminating 30-22 AWG [0.05-0.3 mm²] wire range; .054 [1.37] max. insulation diameter with an insulation wall thickness of .015 [0.38] max.

■ Choice of gold duplex or tin plated contacts

■ Interchangeable crimp snap-in pin and receptacle contacts available

■ Housing sizes 2 through 25 positions, single row .100 [2.54] centers

■ Plain housings are end-to-end and/or back-to-back stackable for open pin field applications

■ Optional header "hold down" feature prevents movement prior to flow soldering

■ Integral latch provides positive retention between header and receptacle housing

■ Coupling shrouds permit ganging of smaller connectors with guide ribs to form larger single or double row latching connectors

■ Mass terminating tooling assures lowest applied cost for all production needs

■ SMT compatible, high-temp headers available

■ Recognized under the Component Program of Underwriters Laboratories Inc. File No. E28476 

■ Certified by Canadian Standards Association File No. LR16455 