

54AC/74AC643 • 54ACT/74ACT643

Octal Bidirectional Transceiver With 3-State Outputs

Description

The 'AC/ACT643 octal bus transceiver is designed for asynchronous two-way communication between data buses. The device transmits data from bus A to bus B when T/\bar{R} = HIGH, or from bus B to bus A when T/\bar{R} = LOW. The enable input can be used to disable the device so the buses are effectively isolated.

- Noninverting Buffers
- Bidirectional Data Path
- A and B Outputs Sink 24 mA/Source -24 mA
- 'ACT643 has TTL-Compatible Inputs

Ordering Code: See Section 6

Pin Names

- A₀ - A₇ Side A Inputs or 3-State Outputs
- $\bar{O}E$ Output Enable Input
- T/\bar{R} Transmit/Receive Input
- B₀ - B₇ Side B Inputs or 3-State Outputs

Truth Table

$\bar{O}E$	T/\bar{R}	Applied Inputs	Valid Direction I/P→O/P	Output
H	X	X	X	X
L	H	H	A to B	L
L	H	L	A to B	H
L	L	H	B to A	H
L	L	L	B to A	L

H = HIGH Voltage Level
 L = LOW Voltage Level
 X = Immaterial

Connection Diagrams

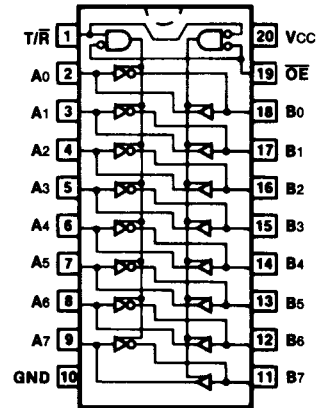

Pin Assignment for DIP, Flatpak and SOIC

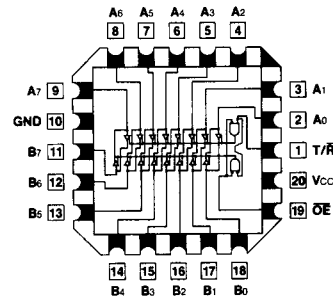

Pin Assignment for LCC

AC643 • ACT643

DC Characteristics (unless otherwise specified)

Symbol	Parameter	54AC/ACT	74AC/ACT	Units	Conditions
I _{CC}	Maximum Quiescent Supply Current	160	80	μA	V _{IN} = V _{CC} or Ground, V _{CC} = 5.5 V, T _A = Worst Case
I _{CC}	Maximum Quiescent Supply Current	8.0	8.0	μA	V _{IN} = V _{CC} or Ground, V _{CC} = 5.5 V, T _A = 25°C
I _{CC(T)}	Maximum Additional I _{CC} /Input (*ACT643)	1.6	1.5	mA	V _{IN} = V _{CC} - 2.1 V, V _{CC} = 5.5 V, T _A = Worst Case

AC Characteristics

Symbol	Parameter	V _{CC} * (V)	74AC			54AC		74AC		Units	Fig. No.
			T _A = +25°C CL = 50 pF			T _A = -55°C to +125°C CL = 50 pF		T _A = -40°C to +85°C CL = 50 pF			
			Min	Typ	Max	Min	Max	Min	Max		
t _{PLH}	Propagation Delay A _n to B _n or B _n to A _n	3.3 5.0	5.5 4.0						ns	3-5	
t _{PHL}	Propagation Delay A _n to B _n or B _n to A _n	3.3 5.0	5.5 4.0						ns	3-5	
t _{PZH}	Output Enable Time	3.3 5.0	8.0 6.0						ns	3-7	
t _{PZL}	Output Enable Time	3.3 5.0	7.5 5.5						ns	3-8	
t _{PHZ}	Output Disable Time	3.3 5.0	7.0 6.0						ns	3-7	
t _{PLZ}	Output Disable Time	3.3 5.0	7.5 6.0						ns	3-8	

*Voltage Range 3.3 is 3.3 V ± 0.3 V
Voltage Range 5.0 is 5.0 V ± 0.5 V

Military parameters given herein are for general references only. For current military specifications and subgroup testing information please request Fairchild's Table I data sheet from your Fairchild sales engineer or account representative.

AC Characteristics

Symbol	Parameter	Vcc* (V)	74ACT			54ACT		74ACT		Units	Fig. No.
			TA = +25°C CL = 50 pF			TA = -55°C to +125°C CL = 50 pF		TA = -40°C to +85°C CL = 50 pF			
			Min	Typ	Max	Min	Max	Min	Max		
tPLH	Propagation Delay An to Bn or Bn to An	5.0		5.0					ns	3-5	
tPHL	Propagation Delay An to Bn or Bn to An	5.0		5.0					ns	3-5	
tpZH	Output Enable Time	5.0		7.0					ns	3-7	
tpZL	Output Enable Time	5.0		6.0					ns	3-8	
tPHZ	Output Disable Time	5.0		6.5					ns	3-7	
tPLZ	Output Disable Time	5.0		6.0					ns	3-8	

*Voltage Range 5.0 is 5.0 V ± 0.5 V

Military parameters given herein are for general references only. For current military specifications and subgroup testing information please request Fairchild's Table I data sheet from your Fairchild sales engineer or account representative.

5

Capacitance

Symbol	Parameter	54/74AC/ACT	Units	Conditions
		Typ		
C _{IN}	Input Capacitance	4.5	pF	Vcc = 5.5 V
C _{I/O}	Input/Output Capacitance	15.0	pF	Vcc = 5.5 V
C _{PD}	Power Dissipation Capacitance		pF	Vcc = 5.5 V