

PRELIMINARY DATA SHEET

NEC

**NPN SILICON RF TRANSISTOR
2SC5508**

**NPN SILICON RF TRANSISTOR
FOR LOW NOISE, HIGH-GAIN AMPLIFICATION
FLAT-LEAD 4-PIN THIN SUPER MINI-MOLD**

FEATURES

- Ideal for low-noise, high-gain amplification applications
- $NF = 1.1 \text{ dB}$, $G_a = 16 \text{ dB TYP.}$ @ $f = 2 \text{ GHz}$, $V_{CE} = 2 \text{ V}$, $I_c = 5 \text{ mA}$
- Maximum available power gain: $MAG = 19 \text{ dB TYP.}$ @ $f = 2 \text{ GHz}$, $V_{CE} = 2 \text{ V}$, $I_c = 20 \text{ mA}$
- $f_T = 25 \text{ GHz}$ technology
- Flat-lead 4-pin thin super mini-mold ($t = 0.59 \text{ mm}$)

ORDERING INFORMATION

Part Number	Quantity	Packaging Style
2SC5508	Loose product (50 pcs)	<ul style="list-style-type: none"> • 8 mm wide emboss taping • 1 pin (emitter), 2 pin (collector) feed hole direction
2SC5508-T2	Taping product (3 kpcs/reel)	

Remark To order evaluation samples, consult your NEC sales representative (available in 50-pcs units).

ABSOLUTE MAXIMUM RATINGS

Parameter	Symbol	Ratings	Unit
Collector to Base Voltage	V_{CBO}	15	V
Collector to Emitter Voltage	V_{CEO}	3.3	V
Emitter to Base Voltage	V_{EBO}	1.5	V
Collector Current	I_c	35	mA
Total Power Dissipation	P_{tot}^{Note}	115	mW
Junction Temperature	T_j	150	°C
Storage Temperature	T_{stg}	-65 to +150	°C

Note $T_A = +25 \text{ °C}$ (free air)

THERMAL RESISTANCE

Item	Symbol	Value	Unit
Junction to Case Resistance	R_{th-j-c}	150	°C/W
Junction to Ambient Resistance	R_{th-j-a}	650	°C/W

Because this product uses high-frequency technology, avoid excessive static electricity, etc.

The information in this document is subject to change without notice.

ELECTRICAL CHARACTERISTICS (TA = +25 °C)

Parameter	Symbol	Test Conditions	MIN.	TYP.	MAX.	Unit
DC Characteristics						
Collector Cut-off Current	ICBO	V _{CB} = 5 V, I _E = 0	–	–	200	nA
Emitter Cut-off Current	IEBO	V _{EB} = 1 V, I _C = 0	–	–	200	nA
DC Current Gain	h _{FE} ^{Note 1}	V _{CE} = 2 V, I _C = 5 mA	50	70	100	–
RF Characteristics						
Reverse Transfer Capacitance	C _{re} ^{Note 2}	V _{CB} = 2 V, I _E = 0, f = 1 MHz	–	0.18	0.24	pF
Gain Bandwidth Product	f _T	V _{CE} = 3 V, I _C = 30 mA, f = 2 GHz	20	25	–	GHz
Noise Figure	NF	V _{CE} = 2 V, I _C = 5 mA, f = 2 GHz, Z _S = Z _{opt}	–	1.1	1.5	dB
Insertion Power Gain	S _{21e} ²	V _{CE} = 2 V, I _C = 20 mA, f = 2 GHz	14	17	–	dB
Maximum Available Power Gain	MAG ^{Note 3}	V _{CE} = 2 V, I _C = 20 mA, f = 2 GHz	–	19	–	–
Maximum Stable Power Gain	MSG ^{Note 4}	V _{CE} = 2 V, I _C = 20 mA, f = 2 GHz	–	20	–	dB
Output Power at 1 dB Compression Point	P ₋₁	V _{CE} = 2 V, I _C = 20 mA ^{Note 5} , f = 2 GHz	–	11	–	dBm
Output Power at Third Order Intercept Point	OIP ₃	V _{CE} = 2 V, I _C = 20 mA ^{Note 5} , f = 2 GHz	–	22	–	–

- Notes**
1. Pulse measurement PW ≤ 350 μs, Duty cycle ≤ 2 %
 2. Emitter to base capacitance measured using capacitance meter (self-balancing bridge method) when the emitter is connected to the guard pin
 3. $MAG = \left| \frac{S_{21}}{S_{12}} \right| \left[k - \sqrt{(k^2 - 1)} \right]$
 4. $MSG = \left| \frac{S_{21}}{S_{12}} \right|$
 5. Collector current when P₋₁ is output

h_{FE} CLASSIFICATION

Rank	FB
Marking	T79
h _{FE}	50 to 100

TYPICAL CHARACTERISTICS ($T_A = +25\text{ }^\circ\text{C}$)

Thermal/DC Characteristics

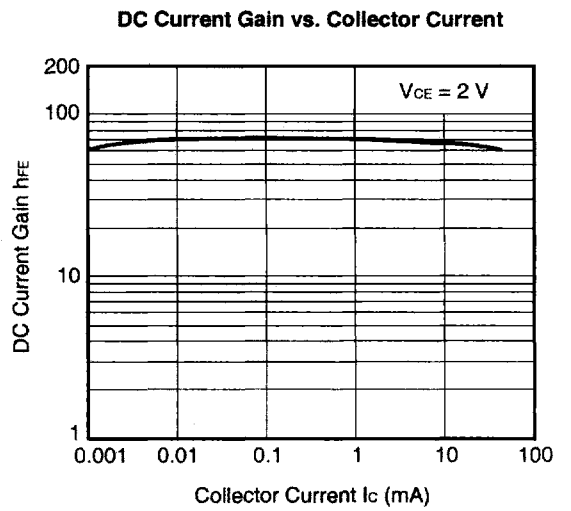
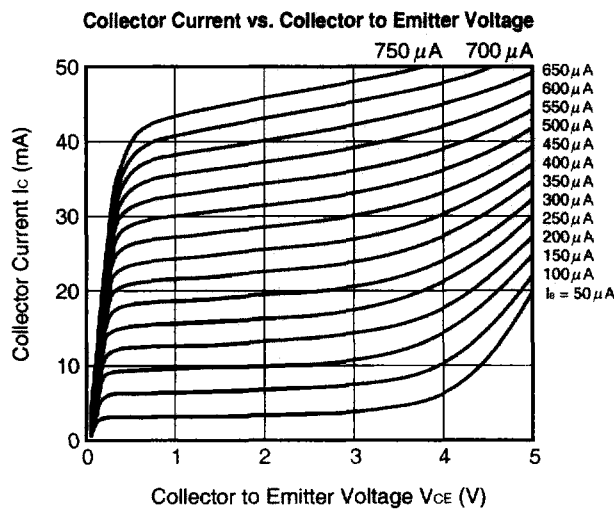
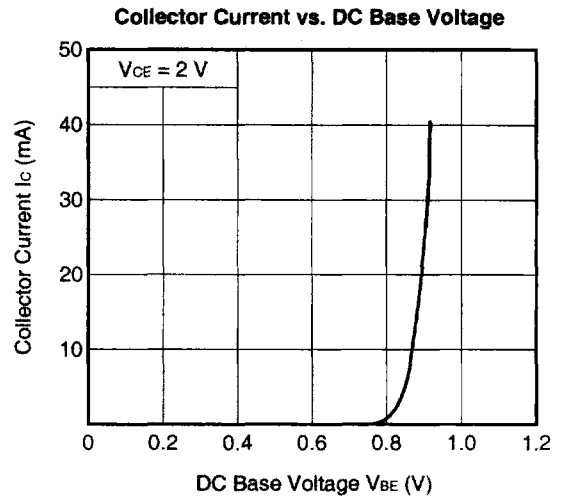
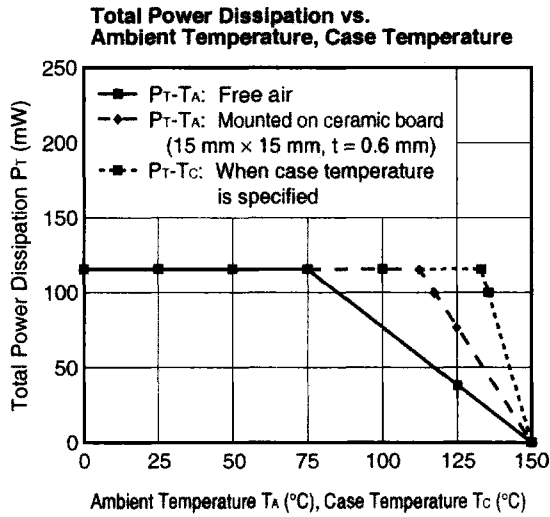

Capacitance/ f_r Characteristics

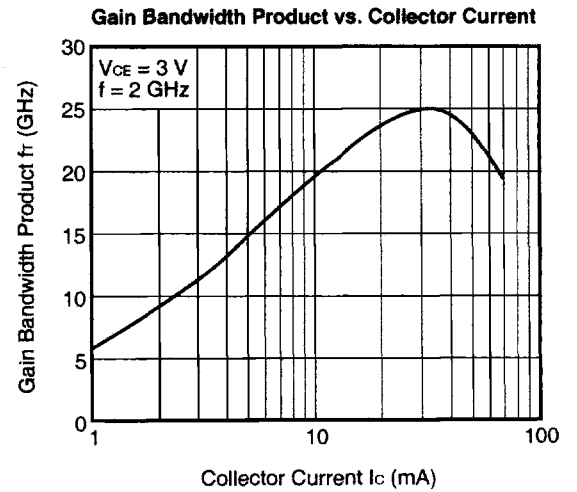
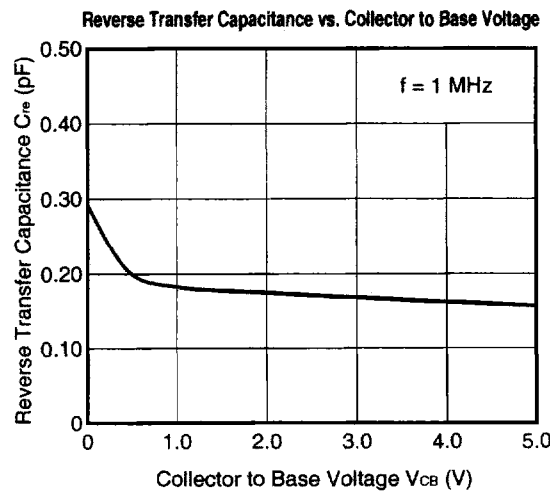

Gain Characteristics

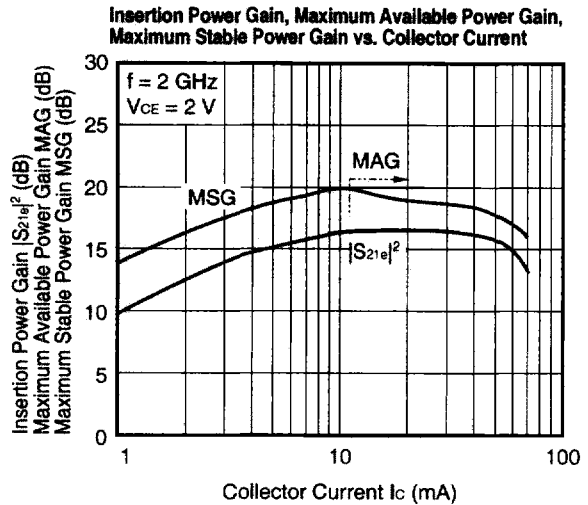
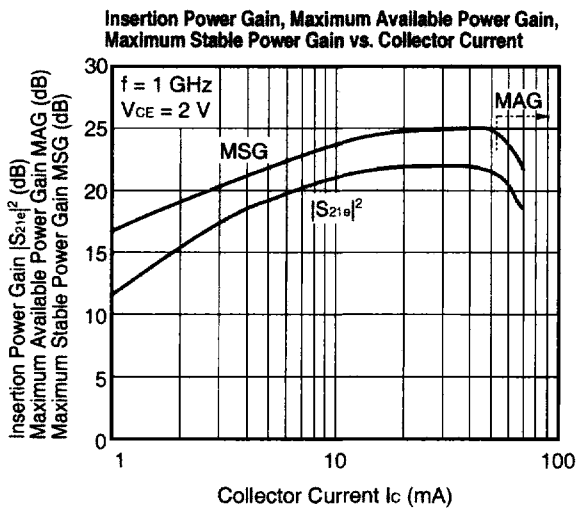
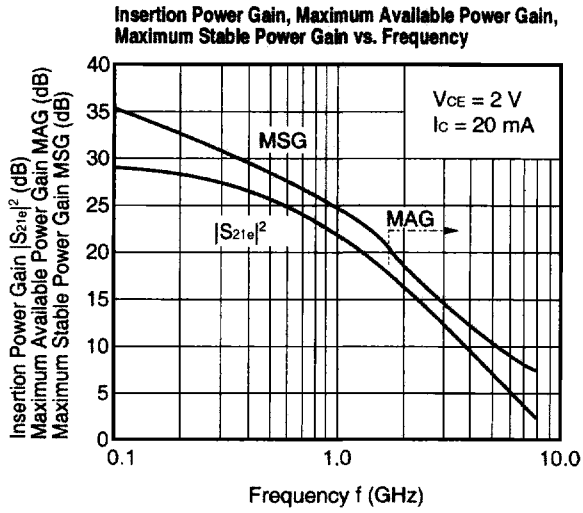

Output Characteristics

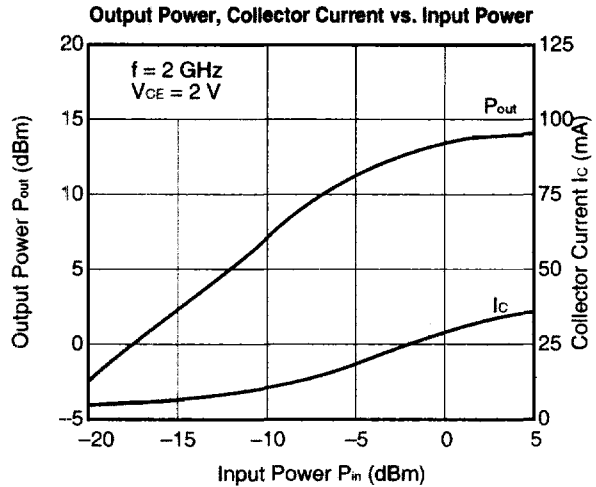
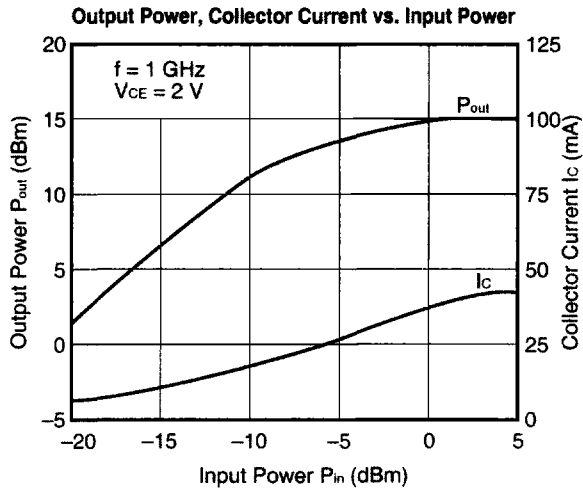

Noise Characteristics

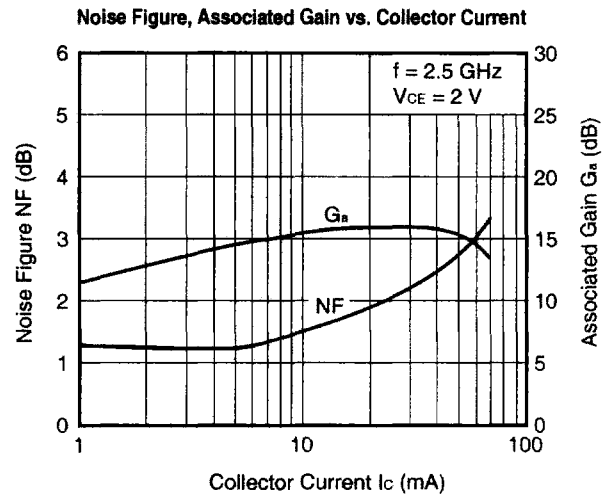
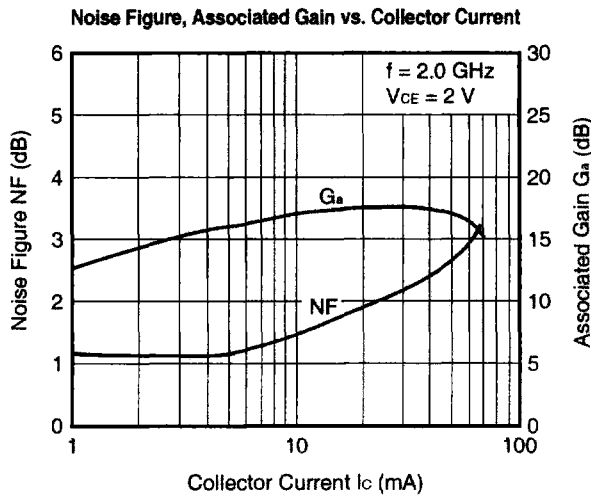
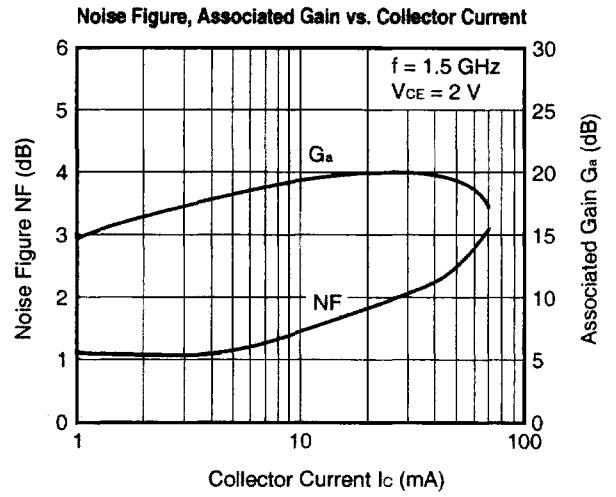
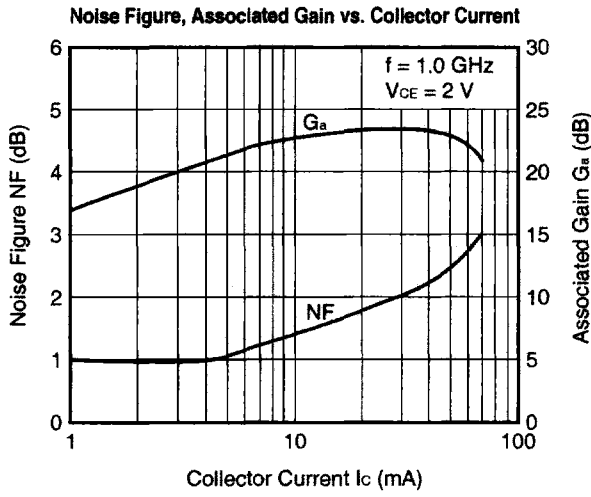

S PARAMETER

V_{CE} = 2 V, I_C = 3 mA

Frequency GHz	S ₁₁		S ₂₁		S ₁₂		S ₂₂	
	MAG.	ANG.	MAG.	ANG.	MAG.	ANG.	MAG.	ANG.
0.1	0.82	-9.0	10.69	170.8	0.01	82.1	0.98	-6.1
0.2	0.81	-17.5	10.04	163.4	0.02	76.0	0.95	-11.6
0.3	0.80	-25.8	9.59	156.9	0.03	71.8	0.91	-16.1
0.4	0.78	-33.6	9.10	150.9	0.04	67.5	0.88	-20.2
0.5	0.76	-41.4	8.74	145.4	0.04	63.8	0.85	-23.8
0.6	0.74	-49.0	8.34	140.3	0.05	60.1	0.81	-27.2
0.7	0.72	-56.8	8.03	135.3	0.05	56.5	0.78	-30.5
0.8	0.70	-64.1	7.69	130.8	0.06	53.7	0.75	-33.5
0.9	0.68	-71.4	7.41	126.0	0.07	50.3	0.72	-36.5
1.0	0.66	-78.6	7.09	121.6	0.07	47.1	0.69	-39.3
1.1	0.64	-86.1	6.85	117.2	0.07	44.7	0.66	-41.9
1.2	0.63	-93.2	6.58	113.1	0.08	42.2	0.63	-44.4
1.3	0.61	-100.5	6.33	108.8	0.08	39.4	0.60	-46.8
1.4	0.60	-107.4	6.07	105.1	0.08	37.3	0.58	-49.0
1.5	0.58	-114.6	5.85	101.1	0.08	35.3	0.55	-51.1
1.6	0.57	-121.5	5.63	97.3	0.09	33.3	0.53	-53.3
1.7	0.56	-128.1	5.43	93.6	0.09	31.4	0.50	-55.3
1.8	0.55	-134.4	5.20	90.1	0.09	29.7	0.48	-57.1
1.9	0.55	-141.0	5.02	86.6	0.09	28.6	0.46	-59.0
2.0	0.54	-147.2	4.84	83.4	0.09	27.0	0.44	-60.9
2.1	0.54	-153.0	4.64	80.1	0.09	25.5	0.42	-62.8
2.2	0.54	-158.7	4.48	76.9	0.09	24.1	0.40	-64.3
2.3	0.54	-164.3	4.32	73.8	0.09	23.1	0.39	-66.3
2.4	0.54	-169.3	4.16	70.9	0.09	21.9	0.37	-68.1
2.5	0.54	-174.3	4.01	68.1	0.10	21.2	0.35	-70.0
2.6	0.55	-179.2	3.87	65.1	0.09	20.6	0.34	-71.9
2.7	0.55	176.3	3.74	62.3	0.09	19.6	0.33	-73.8
2.8	0.55	171.9	3.61	59.5	0.10	19.2	0.31	-75.7
2.9	0.56	167.9	3.48	57.0	0.10	18.6	0.30	-77.8
3.0	0.57	164.1	3.38	54.5	0.10	17.9	0.29	-80.1
4.0	0.66	142.0	2.45	38.2	0.10	12.8	0.20	-106.9
5.0	0.72	124.8	1.90	20.7	0.10	13.4	0.19	-140.5
6.0	0.77	112.4	1.53	5.3	0.10	13.2	0.22	-171.1
7.0	0.80	101.6	1.26	-9.4	0.11	11.8	0.29	167.7
8.0	0.84	93.5	1.04	-22.2	0.12	9.7	0.37	152.4

V_{CE} = 2 V, I_c = 5 mA

Frequency GHz	S ₁₁		S ₂₁		S ₁₂		S ₂₂	
	MAG.	ANG.	MAG.	ANG.	MAG.	ANG.	MAG.	ANG.
0.1	0.75	-11.1	14.43	169.5	0.01	82.3	0.97	-7.6
0.2	0.74	-21.5	13.69	160.9	0.02	75.0	0.93	-14.2
0.3	0.72	-31.7	12.98	153.5	0.03	69.7	0.89	-19.8
0.4	0.69	-41.3	12.27	146.7	0.03	64.7	0.84	-24.6
0.5	0.67	-50.6	11.67	140.5	0.04	61.2	0.80	-28.9
0.6	0.64	-59.6	11.06	134.8	0.04	57.2	0.76	-32.9
0.7	0.62	-68.5	10.51	129.5	0.05	53.9	0.72	-36.4
0.8	0.60	-77.1	9.98	124.5	0.05	51.7	0.68	-39.5
0.9	0.58	-85.4	9.49	119.5	0.06	48.6	0.64	-42.7
1.0	0.56	-93.6	9.00	114.9	0.06	45.8	0.61	-45.5
1.1	0.54	-101.6	8.58	110.4	0.06	43.9	0.57	-48.0
1.2	0.53	-109.2	8.17	106.2	0.07	42.3	0.54	-50.3
1.3	0.51	-116.7	7.77	102.1	0.07	40.2	0.51	-52.6
1.4	0.50	-124.2	7.40	98.3	0.07	38.6	0.48	-54.9
1.5	0.49	-131.5	7.07	94.5	0.07	37.2	0.46	-56.8
1.6	0.48	-138.3	6.74	91.0	0.07	36.1	0.43	-58.8
1.7	0.48	-144.8	6.45	87.7	0.08	35.3	0.41	-60.8
1.8	0.48	-151.1	6.16	84.2	0.08	33.8	0.39	-62.4
1.9	0.47	-157.2	5.90	81.1	0.08	33.1	0.37	-64.4
2.0	0.48	-163.1	5.65	78.1	0.08	32.5	0.35	-66.2
2.1	0.48	-168.7	5.41	75.0	0.08	31.3	0.34	-68.0
2.2	0.48	-174.0	5.20	72.2	0.08	30.6	0.32	-69.7
2.3	0.48	-179.0	4.99	69.4	0.08	29.6	0.30	-71.6
2.4	0.49	176.2	4.78	66.7	0.08	29.8	0.29	-73.8
2.5	0.50	171.9	4.60	64.2	0.08	28.6	0.27	-75.9
2.6	0.50	167.6	4.42	61.5	0.09	28.3	0.26	-77.6
2.7	0.51	163.8	4.27	59.0	0.09	27.9	0.25	-80.3
2.8	0.52	159.9	4.11	56.5	0.09	27.3	0.24	-82.9
2.9	0.53	156.5	3.97	54.1	0.09	27.4	0.22	-85.1
3.0	0.54	153.2	3.85	51.8	0.09	26.7	0.21	-87.8
4.0	0.64	136.4	2.74	37.4	0.09	22.6	0.14	-127.0
5.0	0.70	121.3	2.13	21.1	0.10	21.2	0.16	-164.7
6.0	0.75	110.6	1.72	6.5	0.11	18.9	0.21	168.2
7.0	0.79	99.7	1.42	-7.7	0.12	15.1	0.28	152.1
8.0	0.82	92.7	1.19	-19.8	0.13	11.4	0.36	140.0

V_{CE} = 2 V, I_C = 10 mA

Frequency GHz	S ₁₁		S ₂₁		S ₁₂		S ₂₂	
	MAG.	ANG.	MAG.	ANG.	MAG.	ANG.	MAG.	ANG.
0.1	0.63	-15.1	20.76	167.3	0.01	80.6	0.95	-10.0
0.2	0.61	-29.6	19.66	156.9	0.02	72.0	0.90	-18.5
0.3	0.58	-43.0	18.37	148.0	0.02	66.8	0.83	-25.6
0.4	0.55	-55.6	17.15	140.0	0.03	62.9	0.77	-31.5
0.5	0.52	-67.5	15.96	132.9	0.03	58.7	0.71	-36.1
0.6	0.50	-78.7	14.82	126.5	0.04	56.0	0.66	-40.5
0.7	0.48	-89.4	13.79	120.7	0.04	53.3	0.61	-44.1
0.8	0.46	-99.6	12.85	115.4	0.04	51.8	0.56	-47.1
0.9	0.44	-108.8	11.98	110.5	0.05	49.6	0.52	-49.9
1.0	0.43	-118.0	11.20	105.9	0.05	48.0	0.48	-52.3
1.1	0.42	-126.5	10.49	101.6	0.05	47.4	0.45	-54.5
1.2	0.41	-134.4	9.84	97.8	0.05	46.7	0.42	-56.5
1.3	0.41	-142.0	9.24	94.1	0.06	45.4	0.39	-58.4
1.4	0.41	-149.1	8.70	90.6	0.06	45.0	0.37	-60.2
1.5	0.41	-155.7	8.23	87.3	0.06	44.9	0.35	-62.0
1.6	0.41	-161.9	7.80	84.1	0.06	43.8	0.33	-63.8
1.7	0.41	-167.7	7.40	81.1	0.06	43.4	0.31	-65.7
1.8	0.42	-173.1	7.03	78.1	0.07	42.8	0.29	-67.2
1.9	0.42	-178.0	6.69	75.5	0.07	42.5	0.27	-69.3
2.0	0.43	177.2	6.38	72.8	0.07	42.3	0.26	-71.0
2.1	0.44	172.7	6.09	70.2	0.07	41.1	0.24	-73.1
2.2	0.44	168.6	5.82	67.6	0.07	41.0	0.23	-75.0
2.3	0.45	164.7	5.59	65.2	0.08	40.3	0.21	-77.7
2.4	0.46	161.1	5.34	62.8	0.08	40.2	0.20	-79.8
2.5	0.47	157.8	5.12	60.5	0.08	38.9	0.19	-82.6
2.6	0.48	154.3	4.93	58.2	0.08	38.9	0.18	-85.3
2.7	0.48	151.3	4.75	55.9	0.08	39.1	0.17	-88.5
2.8	0.49	148.2	4.56	53.8	0.09	37.4	0.16	-92.0
2.9	0.50	145.5	4.40	51.6	0.09	37.4	0.15	-95.6
3.0	0.51	143.0	4.28	49.6	0.09	36.4	0.14	-99.6
4.0	0.63	130.0	3.01	36.5	0.10	31.7	0.12	-162.6
5.0	0.69	117.3	2.34	21.3	0.11	28.0	0.17	165.5
6.0	0.75	107.8	1.90	7.9	0.12	23.2	0.23	146.7
7.0	0.78	97.5	1.57	-5.5	0.13	17.2	0.30	135.7
8.0	0.82	91.1	1.32	-17.0	0.14	12.4	0.36	127.0

$V_{CE} = 2\text{ V}$, $I_C = 20\text{ mA}$

Frequency GHz	S ₁₁		S ₂₁		S ₁₂		S ₂₂	
	MAG.	ANG.	MAG.	ANG.	MAG.	ANG.	MAG.	ANG.
0.1	0.48	-21.4	27.42	164.9	0.01	78.5	0.93	-12.3
0.2	0.46	-41.3	25.60	152.5	0.02	70.7	0.85	-22.8
0.3	0.43	-59.2	23.38	142.0	0.02	65.2	0.77	-31.0
0.4	0.41	-75.4	21.22	133.1	0.02	61.7	0.69	-37.2
0.5	0.39	-89.9	19.27	125.5	0.03	58.8	0.62	-42.0
0.6	0.38	-102.6	17.45	118.9	0.03	56.6	0.56	-46.2
0.7	0.37	-114.2	15.92	113.2	0.04	55.4	0.51	-49.5
0.8	0.36	-124.7	14.56	108.1	0.04	54.7	0.46	-52.0
0.9	0.36	-134.1	13.39	103.6	0.04	53.5	0.43	-54.3
1.0	0.36	-142.6	12.35	99.3	0.04	53.3	0.39	-56.4
1.1	0.36	-150.5	11.45	95.4	0.05	52.9	0.36	-58.1
1.2	0.36	-157.4	10.65	91.9	0.05	52.5	0.34	-60.0
1.3	0.37	-163.8	9.94	88.5	0.05	51.5	0.31	-61.6
1.4	0.37	-169.6	9.30	85.5	0.05	51.4	0.29	-63.3
1.5	0.38	-175.2	8.76	82.4	0.05	51.0	0.27	-64.8
1.6	0.39	179.9	8.26	79.5	0.06	50.8	0.25	-66.6
1.7	0.40	175.3	7.81	77.0	0.06	50.2	0.24	-68.4
1.8	0.40	171.1	7.39	74.3	0.06	49.8	0.22	-70.3
1.9	0.41	167.1	7.02	71.8	0.06	49.7	0.21	-72.4
2.0	0.42	163.4	6.68	69.2	0.07	49.4	0.19	-74.6
2.1	0.43	159.9	6.35	67.0	0.07	48.5	0.18	-77.1
2.2	0.44	156.6	6.08	64.7	0.07	48.1	0.17	-79.3
2.3	0.45	153.4	5.81	62.4	0.07	46.5	0.16	-82.6
2.4	0.46	150.6	5.56	60.2	0.08	46.2	0.15	-85.9
2.5	0.47	147.9	5.35	58.0	0.08	45.3	0.14	-89.5
2.6	0.47	145.2	5.12	56.0	0.08	45.4	0.13	-93.5
2.7	0.48	142.8	4.93	53.8	0.08	44.7	0.12	-97.7
2.8	0.49	140.2	4.72	51.7	0.09	43.5	0.11	-103.0
2.9	0.50	138.0	4.58	49.9	0.09	43.4	0.11	-108.0
3.0	0.51	136.0	4.43	47.8	0.09	42.2	0.10	-113.9
4.0	0.64	125.8	3.08	35.5	0.10	36.2	0.13	172.2
5.0	0.70	114.7	2.39	21.1	0.12	30.9	0.19	149.5
6.0	0.75	105.8	1.94	8.2	0.13	24.6	0.26	135.5
7.0	0.78	96.0	1.60	-4.5	0.14	18.4	0.32	126.7
8.0	0.82	89.8	1.36	-15.6	0.14	13.0	0.38	119.4
9.0	0.83	83.4	1.17	-26.8	0.15	6.5	0.43	114.0
10.0	0.86	78.9	1.00	-35.9	0.15	1.6	0.48	109.5

NOISE PARAMETER

<Equal NF circle>

V_{CE} = 2 V
I_c = 5 mA
f = 1 GHz

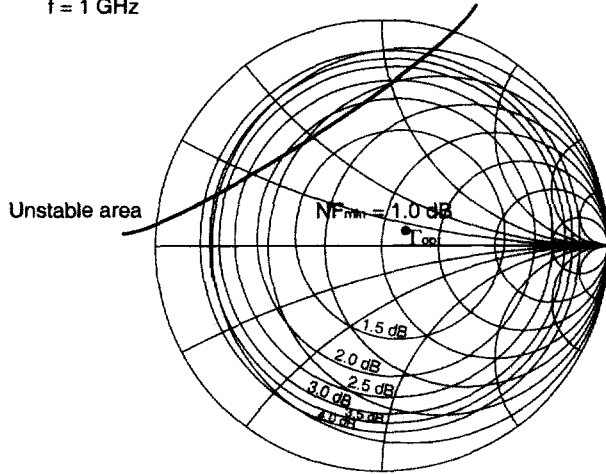

V_{CE} = 2 V
I_c = 5 mA
f = 2 GHz

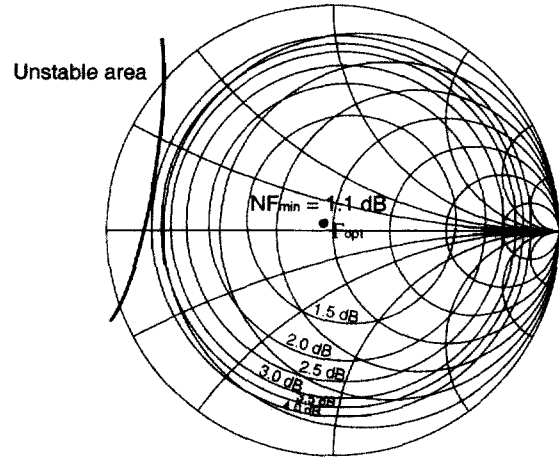

V_{CE} = 2 V, I_c = 3 mA

f (GHz)	NF _{min} (dB)	G _a (dB)	Γ _{opt}		Rn/50
			MAG.	ANG.	
0.8	0.78	21.4	0.26	31.7	0.17
0.9	0.80	20.7	0.26	32.7	0.17
1.0	0.82	20.0	0.26	34.7	0.17
1.5	0.93	17.0	0.23	57.0	0.16
1.8	1.00	15.6	0.20	78.0	0.14
1.9	1.02	15.2	0.19	86.0	0.14
2.0	1.04	14.8	0.19	94.2	0.13
2.5	1.15	13.5	0.20	138.3	0.10

V_{CE} = 2 V, I_c = 5 mA

f (GHz)	NF _{min} (dB)	G _a (dB)	Γ _{opt}		Rn/50
			MAG.	ANG.	
0.8	0.93	22.5	0.12	28.1	0.15
0.9	0.94	21.8	0.12	28.8	0.15
1.0	0.96	21.1	0.12	31.7	0.15
1.5	1.03	18.1	0.09	71.1	0.14
1.8	1.07	16.7	0.08	106.2	0.13
1.9	1.09	16.3	0.08	118.5	0.13
2.0	1.10	15.9	0.08	130.5	0.12
2.5	1.17	14.3	0.14	-179.7	0.11

$V_{CE} = 2\text{ V}$, $I_C = 10\text{ mA}$

f (GHz)	NF _{min} (dB)	G _a (dB)	Γ _{opt}		R _n /50
			MAG.	ANG.	
0.8	1.28	23.7	0.07	-159.4	0.13
0.9	1.29	23.0	0.07	-157.5	0.13
1.0	1.30	22.3	0.08	-155.7	0.13
1.5	1.37	19.3	0.13	-149.2	0.13
1.8	1.41	17.8	0.16	-146.1	0.13
1.9	1.43	17.3	0.17	-145.0	0.13
2.0	1.44	16.9	0.19	-143.9	0.13
2.5	1.51	15.3	0.25	-136.7	0.13

$V_{CE} = 2\text{ V}$, $I_C = 20\text{ mA}$

f (GHz)	NF _{min} (dB)	G _a (dB)	Γ _{opt}		R _n /50
			MAG.	ANG.	
0.8	1.59	24.5	0.26	-158.1	0.12
0.9	1.61	23.7	0.26	-155.5	0.13
1.0	1.63	23.0	0.27	-153.1	0.13
1.5	1.72	19.9	0.30	-142.6	0.14
1.8	1.78	18.3	0.33	-137.3	0.15
1.9	1.79	17.9	0.34	-135.7	0.06
2.0	1.81	17.5	0.35	-134.1	0.16
2.5	1.90	15.8	0.40	-126.5	0.18

PACKAGE DRAWINGS

Flat-lead 4-pin thin super mini-mold (unit: mm)

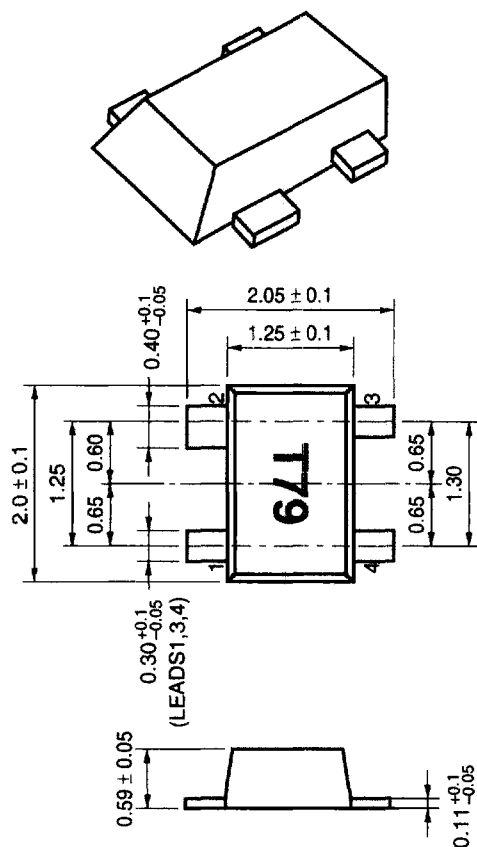

Pin connections

- 1. Emitter
- 2. Collector
- 3. Emitter
- 4. Base

SOLDERING CONDITIONS

Solder this product under the following recommended conditions.

For soldering methods and conditions other than those recommended, consult NEC.

Soldering Method(s)	Soldering Conditions	Recommended Conditions Symbol
Infrared reflow	Package peak temperature: 235 °C, Time: 30 sec max. (210 °C min.), Number of times: twice max., Maximum number of days: None ^{Note}	IR35-00-2
VPS	Package peak temperature: 215 °C, Time: 40 sec max. (200 °C min.), Number of times: twice max., Maximum number of days: None ^{Note}	VP15-00-2
Wave soldering	Solder bath temperature: 260 °C, Time: 10 sec max., Number of times: once, Maximum number of days: None ^{Note}	WS60-00-1

Note Number of days in storage after the dry pack has been opened. The storage conditions are at 25 °C, 65% RH MAX.

Caution Do not use two or more soldering methods in combination.

For details of the recommended soldering conditions, refer to information document **Semiconductor Device Mounting Technology Manual (C10535E)**.

[MEMO]

[MEMO]

No part of this document may be copied or reproduced in any form or by any means without the prior written consent of NEC Corporation. NEC Corporation assumes no responsibility for any errors which may appear in this document.

NEC Corporation does not assume any liability for infringement of patents, copyrights or other intellectual property rights of third parties by or arising from use of a device described herein or any other liability arising from use of such device. No license, either express, implied or otherwise, is granted under any patents, copyrights or other intellectual property rights of NEC Corporation or others.

While NEC Corporation has been making continuous effort to enhance the reliability of its semiconductor devices, the possibility of defects cannot be eliminated entirely. To minimize risks of damage or injury to persons or property arising from a defect in an NEC semiconductor device, customers must incorporate sufficient safety measures in its design, such as redundancy, fire-containment, and anti-failure features.

NEC devices are classified into the following three quality grades:

"Standard", "Special", and "Specific". The Specific quality grade applies only to devices developed based on a customer designated "quality assurance program" for a specific application. The recommended applications of a device depend on its quality grade, as indicated below. Customers must check the quality grade of each device before using it in a particular application.

Standard: Computers, office equipment, communications equipment, test and measurement equipment, audio and visual equipment, home electronic appliances, machine tools, personal electronic equipment and industrial robots

Special: Transportation equipment (automobiles, trains, ships, etc.), traffic control systems, anti-disaster systems, anti-crime systems, safety equipment and medical equipment (not specifically designed for life support)

Specific: Aircrafts, aerospace equipment, submersible repeaters, nuclear reactor control systems, life support systems or medical equipment for life support, etc.

The quality grade of NEC devices is "Standard" unless otherwise specified in NEC's Data Sheets or Data Books. If customers intend to use NEC devices for applications other than those specified for Standard quality grade, they should contact an NEC sales representative in advance.

Anti-radioactive design is not implemented in this product.