

**Product Features**

- Near zero propagation delay
- 5 Ohm switches connect inputs to outputs
- Ultra Low Quiescent Power (0.1  $\mu$ A Typical)
  - Ideally suited for notebook applications
- Pin compatible with 74 series 251 logic devices
- Packages available:
  - 16-pin 150 mil wide plastic QSOP (Q)
  - 16-pin 150 mil wide plastic SOIC (W)
  - 16-pin 173 mil wide plastic TSSOP (L)

**Product Description**

Pericom Semiconductor's PI3B series of logic circuits are produced using the Company's advanced sub micron CMOS technology, achieving industry leading performance.

The PI3B3251 is a 3.3V Dual 8:1 Multiplexer/demultiplexer with three-state outputs that is pinout compatible with the PI74FCT251T, 74F251, and 74ALS/AS/LS 251. Inputs can be connected to outputs with low on resistance (5 Ohm) with no additional ground bounce noise or propagation delay.

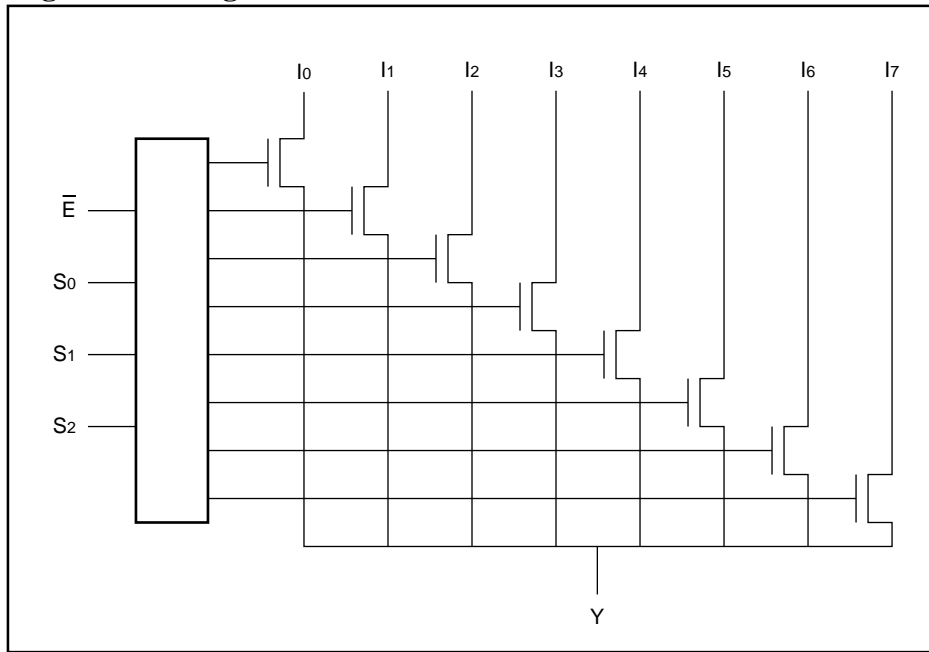
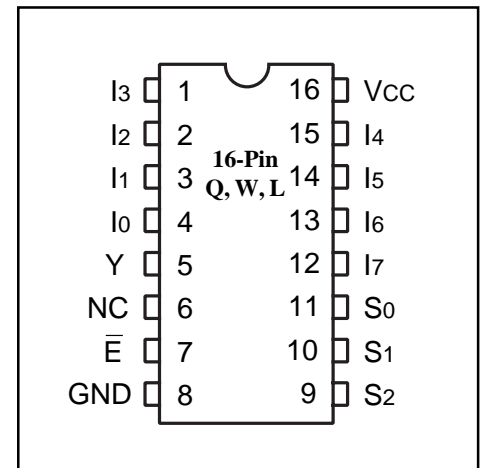
**Logic Block Diagram**

**Product Pin Configuration**

**Product Pin Description**

Pin Name	Description
I0-7	Data Inputs
S0-2	Select Inputs
$\bar{E}$	Enable
Y	Data Outputs
GND	Ground
Vcc	Power

**Truth Table<sup>(1)</sup>**

E	Select			Y	Function
	S2	S1	S0		
H	X	X	X	Hi-Z	Disable
L	L	L	L	I0	S2-0 = 0
L	L	L	H	I1	S2-0 = 1
L	L	H	L	I2	S2-0 = 2
L	L	H	H	I3	S2-0 = 3
L	H	L	L	I4	S2-0 = 4
L	H	L	H	I5	S2-0 = 5
L	H	H	L	I6	S2-0 = 6
L	H	H	H	I7	S2-0 = 7

**Note:**

1. H = High Voltage Level  
L = Low Voltage Level

**Maximum Ratings**

(Above which the useful life may be impaired. For user guidelines, not tested.)

Storage Temperature .....	-65°C to +150°C
Ambient Temperature with Power Applied .....	-40°C to +85°C
Supply Voltage to Ground Potential (Inputs & V <sub>CC</sub> Only) .....	-0.5V to +4.6V
Supply Voltage to Ground Potential (Outputs & D/O Only .....	-0.5V to +4.6V
DC Input Voltage .....	-0.5V to +4.6V
DC Output Current .....	120mA
Power Dissipation .....	0.5W

**Note:**

Stresses greater than those listed under MAXIMUM RATINGS may cause permanent damage to the device. This is a stress rating only and functional operation of the device at these or any other conditions above those indicated in the operational sections of this specification is not implied. Exposure to absolute maximum rating conditions for extended periods may affect reliability.

**DC Electrical Characteristics** (Over the Operating Range, T<sub>A</sub> = -40°C to +85°C, V<sub>CC</sub> = 3.3V ±10%)

Parameters	Description	Test Conditions <sup>(1)</sup>	Min.	Typ <sup>(2)</sup>	Max.	Units
V <sub>IH</sub>	Input HIGH Voltage	Guaranteed Logic HIGH Level	2.0			V
V <sub>IL</sub>	Input LOW Voltage	Guaranteed Logic LOW Level	-0.5		0.8	V
I <sub>IH</sub>	Input HIGH Current	V <sub>CC</sub> = Max., V <sub>IN</sub> = V <sub>CC</sub>			±1	μA
I <sub>IL</sub>	Input LOW Current	V <sub>CC</sub> = Max., V <sub>IN</sub> = GND			±1	μA
I <sub>OZH</sub>	High Impedance Output Current	0 ≤ I <sub>N</sub> , Y <sub>N</sub> ≤ V <sub>CC</sub>			±1	μA
V <sub>IK</sub>	Clamp Diode Voltage	V <sub>CC</sub> = Min., I <sub>IN</sub> = -18mA			-1.2	V
R <sub>ON</sub>	Switch On Resistance <sup>(3)</sup>	V <sub>CC</sub> = Min., V <sub>IN</sub> = 0.0V, I <sub>ON</sub> = 48mA or 64mA V <sub>CC</sub> = Min., V <sub>IN</sub> = 2.4V, I <sub>ON</sub> = 15mA		5 10	8 17	Ω

**Capacitance** (T<sub>A</sub> = 25°C, f = 1 MHz)

Parameters <sup>(5)</sup>	Description	Test Conditions	Typ.	Units
C <sub>IN</sub>	Input Capacitance	V <sub>IN</sub> = 0V	3.0	pF
C <sub>I(OFF)</sub>	I0 - I7 Capacitance, Switch Off	V <sub>IN</sub> = 0V	8.0	pF
C <sub>Y(OFF)</sub>	Y Capacitance, Switch Off	V <sub>IN</sub> = 0V	64.0	pF
C <sub>I(ON)</sub>	I0 - I7 Capacitance, Switch On	V <sub>IN</sub> = 0V	72.0	pF

**Notes:**

1. For Max. or Min. conditions, use appropriate value specified under Electrical Characteristics for the applicable device type.
2. Typical values are at V<sub>CC</sub> = 3.3V, T<sub>A</sub> = 25°C ambient and maximum loading.
3. Measured by the voltage drop between I and Y pin at indicated current through the switch. ON resistance is determined by the lower of the voltages on the two (I, Y) pins.
4. This parameter is determined by device characterization but is not production tested.

### Power Supply Characteristics

Parameters	Description	Test Conditions <sup>(1)</sup>		Min.	Typ. <sup>(2)</sup>	Max.	Units
$I_{CC}$	Quiescent Power Supply Current	$V_{CC} = \text{Max.}$	$V_{IN} = \text{GND or } V_{CC}$		0.1	3	$\mu\text{A}$
$\Delta I_{CC}$	Supply Current per Input @ TTL HIGH	$V_{CC} = \text{Max.}$	$V_{IN} = 3.0\text{V}^{(3)}$			750	$\mu\text{A}$

**Notes:**

1. For Max. or Min. conditions, use appropriate value specified under Electrical Characteristics for the applicable device.
2. Typical values are at  $V_{CC} = 3.3\text{V}$ ,  $+25^\circ\text{C}$  ambient.
3. Per TTL driven input (control input only); I and Y pins do not contribute to  $I_{CC}$ .

### Switching Characteristics over Operating Range

Parameters	Description	Conditions <sup>(1)</sup>	PI3B3251		Units
			Com.		
			Min.	Max.	
$t_{PD}$	Propagation Delay <sup>(2,3)</sup> In to Y	$C_L = 50\text{pF}$ $R_L = 500\Omega$		0.25	ns
$t_{SY}$	Bus Enable Time Sn to Y	$C_L = 50\text{pF}$ $R_L = 500\Omega$	1	4.5	
$t_{PZH}$ $t_{PZL}$	Bus Enable Time E to Y	$C_L = 50\text{pF}$ $R_L = 500\Omega$	1	3.5	
$t_{PHZ}$ $t_{PLZ}$	Bus Disable Time E to Y	$C_L = 50\text{pF}$ $R_L = 500\Omega$	1	5.5	

**Notes:**

1. See test circuit and waveforms.
2. This parameter is guaranteed but not tested on Propagation Delays.
3. The bus switch contributes no propagational delay other than the RC delay of the ON resistance of the switch and the load capacitance. The time constant for the switch alone is of the order of 0.25ns for 50pF load. Since this time constant is much smaller than the rise/fall times of typical driving signals, it adds very little propagational delay to the system. Propagational delay of the bus switch when used in a system is determined by the driving circuit on the driving side of the switch and its interaction with the load on the driven side.

### Ordering Information

Part Number	Pin / Package	Temperature
PI3B3251Q	16-QSOP (Q)	$-40^\circ\text{C}$ to $+85^\circ\text{C}$
PI3B3251W	16-SSOP (W)	$-40^\circ\text{C}$ to $+85^\circ\text{C}$
PI3B3251L	16-TSSOP (L)	$-40^\circ\text{C}$ to $+85^\circ\text{C}$