

OKI Semiconductor

MSM51V17170

1,048,576-Word × 16-Bit DYNAMIC RAM : FAST PAGE MODE TYPE

DESCRIPTION

The MSM51V17170 is a 1,048,576-word × 16-bit dynamic RAM fabricated in OKI's CMOS silicon gate technology. The MSM51V17170 achieves high integration, high-speed operation, and low-power consumption due to quadruple polysilicon double metal CMOS. The MSM51V17170 is available in a 42-pin plastic SOJ or 50/44-pin plastic TSOP.

FEATURES

- 1,048,576-word × 16-bit configuration
- Single 3.3 V power supply, ±0.3 V tolerance
- Input : LVTTTL compatible, low input capacitance
- Output : LVTTTL compatible, 3-state
- Refresh : 2048 cycles/32 ms
- Fast page mode, read modify write capability
- CAS before RAS refresh, hidden refresh, RAS-only refresh capability
- Package options:
 - 42-Pin 400 mil plastic SOJ (SOJ42-P-400) (Product : MSM51V17170-xxJS)
 - 50/44-Pin 400 mil plastic TSOP (TSOP50/44-P-400/0.8-K) (Product : MSM51V17170-xxTS-K)
 - (TSOP50/44-P-400/0.8-L) (Product : MSM51V17170-xxTS-L)xx indicates speed rank.

PRODUCT FAMILY

Family	Access Time (Max.)				Cycle Time (Min.)	Power Dissipation	
	t _{RAC}	t _{AA}	t _{CAC}	t _{OEA}		Operating (Max.)	Standby (Max.)
MSM51V17170-70	70 ns	35 ns	20 ns	20 ns	130 ns	540 mW	3.6 mW
MSM51V17170-80	80 ns	40 ns	20 ns	20 ns	150 ns	504 mW	

PIN CONFIGURATION (TOP VIEW)

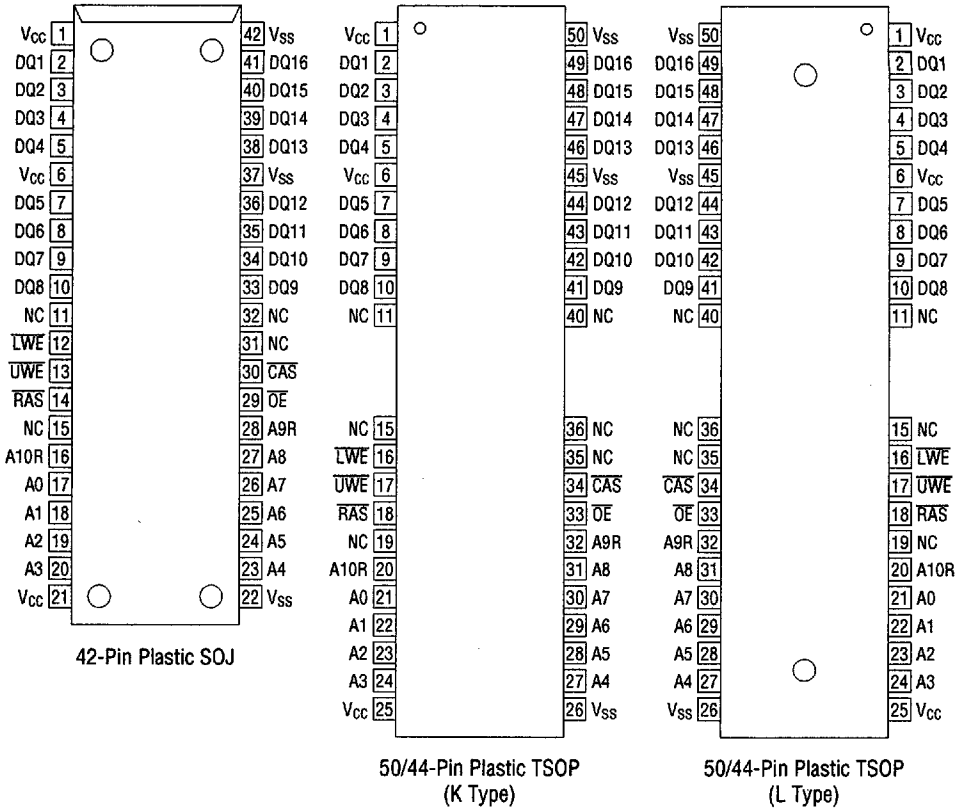

Pin Name	Function
A0 - A8, A9R, A10R	Address Input
RAS	Row Address Strobe
CAS	Column Address Strobe
DQ1 - DQ16	Data Input/Data Output
OE	Output Enable
LWE	Lower Byte Write Enable
UWE	Upper Byte Write Enable
V _{CC}	Power Supply (3.3 V)
V _{SS}	Ground (0 V)
NC	No Connection

Note : The same power supply voltage must be provided to every V_{CC} pin, and the same GND voltage level must be provided to every V_{SS} pin.

BLOCK DIAGRAM

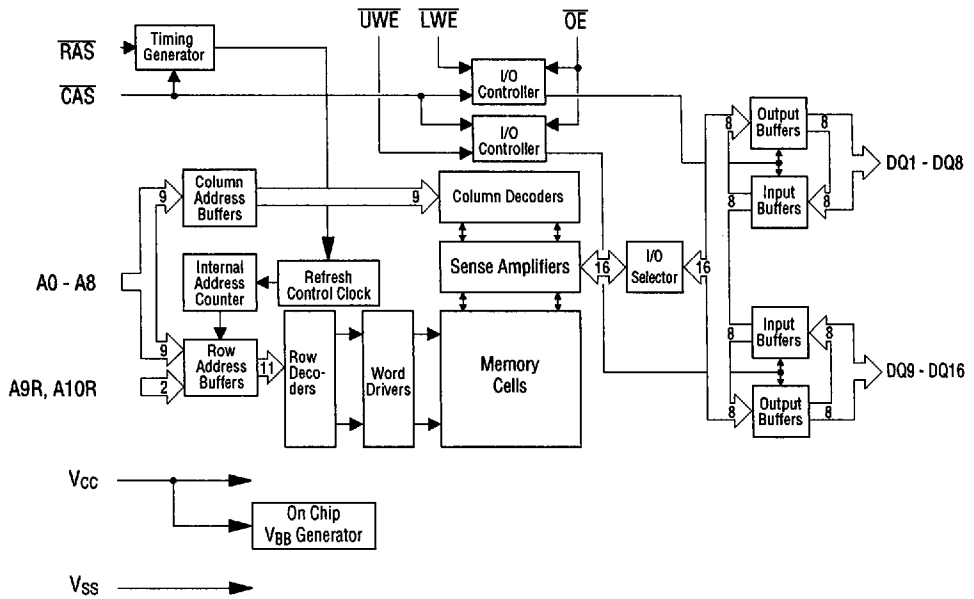

FUNCTION TABLE

Input Pin					DQ Pin		Function Mode
RAS	CAS	LWE	UWE	OE	DQ1 - DQ8	DQ9 - DQ16	
H	*	*	*	*	High-Z	High-Z	Standby
L	H	*	*	*	High-Z	High-Z	Refresh
L	L	H	H	L	D _{OUT}	D _{OUT}	Word Read
L	L	L	H	H	D _{IN}	Don't Care	Lower Byte Write
L	L	H	L	H	Don't Care	D _{IN}	Upper Byte Write
L	L	L	L	H	D _{IN}	D _{IN}	Word Write
L	L	H	H	H	High-Z	High-Z	—

*: "H" or "L"

ELECTRICAL CHARACTERISTICS**Absolute Maximum Ratings**

Parameter	Symbol	Rating	Unit
Voltage on Any Pin Relative to V_{SS}	V_T	-0.5 to 4.6	V
Short Circuit Output Current	I_{OS}	50	mA
Power Dissipation	P_D^*	1	W
Operating Temperature	T_{opr}	0 to 70	°C
Storage Temperature	T_{stg}	-55 to 150	°C

*: $T_a = 25^\circ\text{C}$ **Recommended Operating Conditions** $(T_a = 0^\circ\text{C to } 70^\circ\text{C})$

Parameter	Symbol	Min.	Typ.	Max.	Unit
Power Supply Voltage	V_{CC}	3.0	3.3	3.6	V
	V_{SS}	0	0	0	V
Input High Voltage	V_{IH}	2.0	—	$V_{CC} + 0.3$	V
Input Low Voltage	V_{IL}	-0.3	—	0.8	V

Capacitance $(V_{CC} = 3.3\text{ V} \pm 0.3\text{ V}, T_a = 25^\circ\text{C}, f = 1\text{ MHz})$

Parameter	Symbol	Typ.	Max.	Unit
Input Capacitance (A0 - A8, A9R, A10R)	C_{IN1}	—	5	pF
Input Capacitance (RAS, CAS, UWE, LWE, OE)	C_{IN2}	—	7	pF
Output Capacitance (DQ1 - DQ16)	$C_{I/O}$	—	7	pF

DC Characteristics

($V_{CC} = 3.3\text{ V} \pm 0.3\text{ V}$, $T_a = 0^\circ\text{C}$ to 70°C)

Parameter	Symbol	Condition	MSM51V17170-70		MSM51V17170-80		Unit	Note
			Min.	Max.	Min.	Max.		
Output High Voltage	V_{OH}	$I_{OH} = -2.0\text{ mA}$	2.4	V_{CC}	2.4	V_{CC}	V	
Output Low Voltage	V_{OL}	$I_{OL} = 2.0\text{ mA}$	0	0.4	0	0.4	V	
Input Leakage Current	I_{LI}	$0\text{ V} \leq V_i \leq V_{CC} + 0.3\text{ V}$; All other pins not under test = 0 V	-10	10	-10	10	μA	
Output Leakage Current	I_{LO}	DQ disable $0\text{ V} \leq V_O \leq 3.6\text{ V}$	-10	10	-10	10	μA	
Average Power Supply Current (Operating)	I_{CC1}	$\overline{\text{RAS}}$, $\overline{\text{CAS}}$ cycling, $t_{RC} = \text{Min.}$	—	150	—	140	mA	1, 2
Power Supply Current (Standby)	I_{CC2}	$\overline{\text{RAS}}$, $\overline{\text{CAS}} = V_{IH}$	—	2	—	2	mA	1
		$\overline{\text{RAS}}$, $\overline{\text{CAS}} \geq V_{CC} - 0.2\text{ V}$	—	1	—	1		
Average Power Supply Current (RAS-only Refresh)	I_{CC3}	$\overline{\text{RAS}}$ cycling, $\overline{\text{CAS}} = V_{IH}$, $t_{RC} = \text{Min.}$	—	150	—	140	mA	1, 2
Power Supply Current (Standby)	I_{CC5}	$\overline{\text{RAS}} = V_{IH}$, $\overline{\text{CAS}} = V_{IL}$, DQ = enable	—	5	—	5	mA	1
Average Power Supply Current ($\overline{\text{CAS}}$ before $\overline{\text{RAS}}$ Refresh)	I_{CC6}	$\overline{\text{RAS}}$ cycling, $\overline{\text{CAS}}$ before $\overline{\text{RAS}}$	—	150	—	140	mA	1, 2
Average Power Supply Current (Fast Page Mode)	I_{CC7}	$\overline{\text{RAS}} = V_{IL}$, $\overline{\text{CAS}}$ cycling, $t_{PC} = \text{Min.}$	—	140	—	130	mA	1, 3

- Notes :
1. I_{CC} Max. is specified as I_{CC} for output open condition.
 2. Address can be changed once or less while $\overline{\text{RAS}} = V_{IL}$.
 3. Address can be changed once or less while $\overline{\text{CAS}} = V_{IH}$.

AC Characteristics (1/2)

 $(V_{CC} = 3.3 V \pm 0.3 V, T_a = 0^\circ C \text{ to } 70^\circ C)$ Note 1, 2, 3

Parameter	Symbol	MSM51V17170-70		MSM51V17170-80		Unit	Note
		Min.	Max.	Min.	Max.		
Random Read or Write Cycle Time	t_{RC}	130	—	150	—	ns	
Read Modify Write Cycle Time	t_{RWC}	180	—	200	—	ns	
Fast Page Mode Cycle Time	t_{PC}	45	—	50	—	ns	
Fast Page Mode Read Modify Write Cycle Time	t_{PRWC}	95	—	100	—	ns	
Access Time from \overline{RAS}	t_{RAC}	—	70	—	80	ns	4, 5, 6
Access Time from \overline{CAS}	t_{CAC}	—	20	—	20	ns	4, 5
Access Time from Column Address	t_{AA}	—	35	—	40	ns	4, 6
Access Time from \overline{CAS} Precharge	t_{CPA}	—	40	—	45	ns	4
Access Time from \overline{OE}	t_{OEA}	—	20	—	20	ns	4
Output Low Impedance Time from \overline{CAS}	t_{CLZ}	0	—	0	—	ns	4
\overline{CAS} to Data Output Buffer Turn-off Delay Time	t_{OFF}	0	15	0	15	ns	7
\overline{OE} to Data Output Buffer Turn-off Delay Time	t_{OEZ}	0	15	0	15	ns	7
Transition Time	t_T	3	50	3	50	ns	3
Refresh Period	t_{REF}	—	32	—	32	ms	
\overline{RAS} Precharge Time	t_{RP}	50	—	60	—	ns	
\overline{RAS} Pulse Width	t_{RAS}	70	10,000	80	10,000	ns	
\overline{RAS} Pulse Width (Fast Page Mode)	t_{RASP}	70	100,000	80	100,000	ns	
\overline{RAS} Hold Time	t_{RSH}	20	—	20	—	ns	
\overline{RAS} Hold Time referenced to \overline{OE}	t_{ROH}	20	—	20	—	ns	
\overline{CAS} Precharge Time (Fast Page Mode)	t_{CP}	10	—	10	—	ns	
\overline{CAS} Pulse Width	t_{CAS}	20	10,000	20	10,000	ns	
\overline{CAS} Hold Time	t_{CSH}	70	—	80	—	ns	
\overline{CAS} to \overline{RAS} Precharge Time	t_{CRP}	10	—	10	—	ns	
\overline{CAS} to \overline{RAS} Precharge Time	t_{RHCP}	40	—	45	—	ns	
\overline{RAS} to \overline{CAS} Delay Time	t_{RCD}	20	50	20	60	ns	5
\overline{RAS} to Column Address Delay Time	t_{RAD}	15	35	15	40	ns	6
Row Address Set-up Time	t_{ASR}	0	—	0	—	ns	
Row Address Hold Time	t_{RAH}	10	—	10	—	ns	
Column Address Set-up Time	t_{ASC}	0	—	0	—	ns	
Column Address Hold Time	t_{CAH}	15	—	15	—	ns	
Column Address Hold Time from \overline{RAS}	t_{AR}	55	—	60	—	ns	
Column Address to \overline{RAS} Lead Time	t_{RAL}	35	—	40	—	ns	
Read Command Set-up Time	t_{RCS}	0	—	0	—	ns	
Read Command Hold Time	t_{RCH}	0	—	0	—	ns	8
Read Command Hold Time referenced to \overline{RAS}	t_{RRH}	0	—	0	—	ns	8

AC Characteristics (2/2)

(V_{CC} = 3.3 V ± 0.3 V, T_a = 0°C to 70°C) Note 1, 2, 3

Parameter	Symbol	MSM51V17170-70		MSM51V17170-80		Unit	Note
		Min.	Max.	Min.	Max.		
Write Command Set-up Time	t _{WCS}	0	—	0	—	ns	9
Write Command Hold Time	t _{WCH}	15	—	15	—	ns	
Write Command Hold Time from $\overline{\text{RAS}}$	t _{WCR}	55	—	60	—	ns	
Write Command Pulse Width	t _{WP}	15	—	15	—	ns	
$\overline{\text{OE}}$ Command Hold Time	t _{OEH}	20	—	20	—	ns	
Write Command to $\overline{\text{RAS}}$ Lead Time	t _{RWL}	20	—	20	—	ns	
Write Command to $\overline{\text{CAS}}$ Lead Time	t _{CWL}	20	—	20	—	ns	
Data-in Set-up Time	t _{DS}	0	—	0	—	ns	10
Data-in Hold Time	t _{DH}	15	—	15	—	ns	10
Data-in Hold Time from $\overline{\text{RAS}}$	t _{DHR}	55	—	60	—	ns	
$\overline{\text{OE}}$ to Data-in Delay Time	t _{OED}	15	—	15	—	ns	
$\overline{\text{CAS}}$ to $\overline{\text{WE}}$ Delay Time	t _{CWD}	45	—	45	—	ns	9
Column Address to $\overline{\text{WE}}$ Delay Time	t _{AWD}	60	—	65	—	ns	9
$\overline{\text{RAS}}$ to $\overline{\text{WE}}$ Delay Time	t _{RWD}	95	—	105	—	ns	9
$\overline{\text{CAS}}$ Precharge $\overline{\text{WE}}$ Delay Time	t _{CPWD}	65	—	75	—	ns	9
$\overline{\text{CAS}}$ Active Delay Time from $\overline{\text{RAS}}$ Precharge	t _{RPC}	10	—	10	—	ns	
$\overline{\text{RAS}}$ to $\overline{\text{CAS}}$ Set-up Time ($\overline{\text{CAS}}$ before $\overline{\text{RAS}}$)	t _{CSR}	10	—	10	—	ns	
$\overline{\text{RAS}}$ to $\overline{\text{CAS}}$ Hold Time ($\overline{\text{CAS}}$ before $\overline{\text{RAS}}$)	t _{CHR}	15	—	15	—	ns	
$\overline{\text{CAS}}$ Precharge Time (Refresh Counter Test)	t _{CPT}	40	—	40	—	ns	

- Notes:
1. A start-up delay of 200 μ s is required after power-up, followed by a minimum of eight initialization cycles ($\overline{\text{RAS}}$ -only refresh or $\overline{\text{CAS}}$ before $\overline{\text{RAS}}$ refresh) before proper device operation is achieved.
 2. The AC characteristics assume $t_T = 5$ ns.
 3. V_{IH} (Min.) and V_{IL} (Max.) are reference levels for measuring input timing signals. Transition times (t_T) are measured between V_{IH} and V_{IL} .
 4. This parameter is measured with a load circuit equivalent to 1 TTL load and 100 pF. Output timing reference levels are $V_{OH} = 2.0$ V and $V_{OL} = 0.8$ V.
 5. Operation within the t_{RCD} (Max.) limit ensures that t_{RAC} (Max.) can be met. t_{RCD} (Max.) is specified as a reference point only. If t_{RCD} is greater than the specified t_{RCD} (Max.) limit, access time is controlled by t_{CAC} .
 6. Operation within the t_{RAD} (Max.) limit ensures that t_{RAC} (Max.) can be met. t_{RAD} (Max.) is specified as a reference point only. If t_{RAD} is greater than the specified t_{RAD} (Max.) limit, access time is controlled by t_{AA} .
 7. t_{OFF} (Max.) and t_{OEZ} (Max.) define the time at which the output achieves the open circuit condition and are not referenced to output voltage levels.
 8. t_{RCH} or t_{RRH} must be satisfied for a read cycle.
 9. t_{WCS} , t_{CWD} , t_{RWD} , t_{AWD} and t_{CPWD} are not restrictive operating parameters. They are included in the data sheet as electrical characteristics only. If $t_{WCS} \geq t_{WCS}$ (Min.), the cycle is an early write cycle and the data out will remain open circuit (high impedance) throughout the entire cycle. If $t_{CWD} \geq t_{CWD}$ (Min.), $t_{RWD} \geq t_{RWD}$ (Min.), $t_{AWD} \geq t_{AWD}$ (Min.) and $t_{CPWD} \geq t_{CPWD}$ (Min.), the cycle is a read modify write cycle and data out will contain data read from the selected cell; if neither of the above sets of conditions is satisfied, the condition of the data out (at access time) is indeterminate.
 10. These parameters are referenced to $\overline{\text{CAS}}$ leading edge in an early write cycle, and to $\overline{\text{WE}}$ leading edge in an $\overline{\text{OE}}$ control write cycle or a read modify write cycle.

See ADDENDUM E for AC Timing Waveforms