



The Future of Analog IC Technology[®]

HR1000

Resonant Half-Bridge Controller

DESCRIPTION

The HR1000 is a controller designed specifically for the resonant half-bridge topology. It provides two drive-signal channels that output complementary signals at a 50% duty cycle. An internal fixed dead-time of 350ns between the two complementary gate signals guarantees zero-voltage switching during the transient and enables high-frequency operation.

The integrated bootstrap diode simplifies the external driving circuit for the high-side switch. It can withstand up to 600V with immunity against high dV/dt noise.

Modulating the switching frequency regulates the topology output voltage. A programmable oscillator can set both the maximum and minimum switching frequencies.

The IC starts up at the programmed maximum switching frequency and gradually slows until the control loop takes over to prevent excessive inrush current.

The IC can be forced to enter a controlled burst-mode operation at light-load to minimize the power consumption and tighten output regulation.

Protections features—including latched shutdown, auto-recovery, brown-out protection, and over-temperature protection—improve converter design safety without engendering additional circuit complexity.

The IC provide 1.5A/2A source/sink capability for both high-side and low-side gate drivers.

The HR1000 is available in a SOIC-16 package.

FEATURES

- 50% Duty Cycle, Variable Frequency Control For Resonant Half-Bridge Converter
- 350ns Fixed Dead-Time
- 600V High-Side Gate Driver with Integrated Bootstrap Diode and High dV/dt Immunity
- 1.5A/2A Source/Sink Capability for Both High-Side and Low-Side Gate Drivers
- High-Accuracy Oscillator
- Operates at up to 600kHz
- Adjustable Maximum and Minimum Switching Frequency
- Two-Level Over-Current Protection: Frequency-Shift and Latched Shutdown with Programmable Duration Time
- Remote ON/OFF Control and Brown-Out Protection through the BO Pin
- Latched-Disable Input for Easy Protections Implementation
- Internal Thermal Shutdown
- Interfaces with PFC Controller
- Programmable Burst-Mode Operation at Light-Load
- Non-Linear Soft-Start for Monotonic Output Voltage Rise
- SO-16 package

APPLICATIONS

- LCD and PDP TVs
- Desktop PCs and Servers
- Telecom SMPS
- AC-DC Adapter, Open-Frame SMPS
- Video Game Consoles
- Electronic Lighting Ballast

All MPS parts are lead-free and adhere to the RoHS directive. For MPS green status, please visit MPS website under Quality Assurance. "MPS" and "The Future of Analog IC Technology" are Registered Trademarks of Monolithic Power Systems, Inc.

TYPICAL APPLICATION BLOCK DIAGRAM

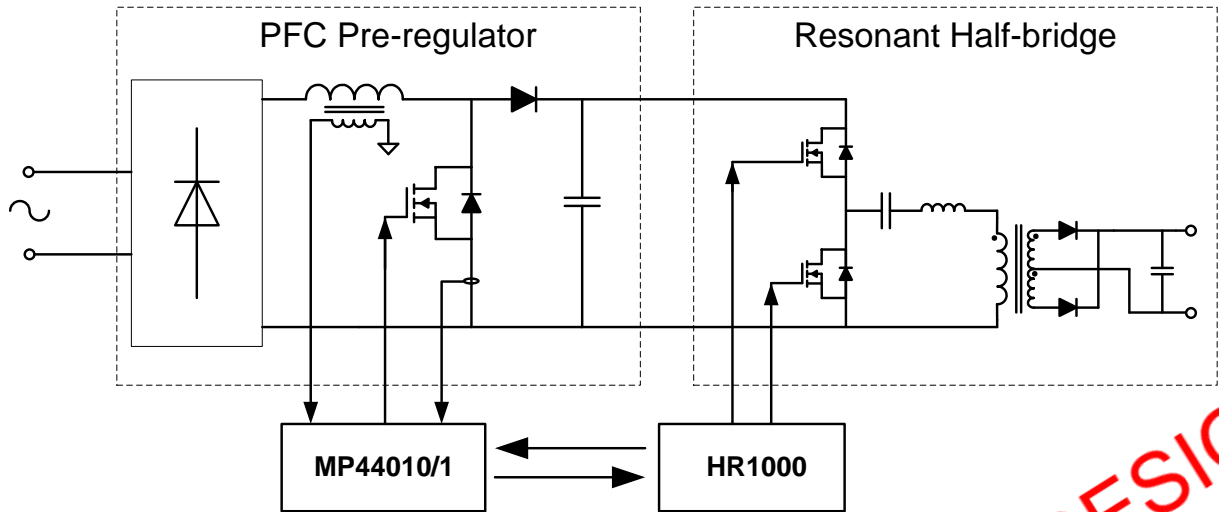

NOT RECOMMENDED FOR NEW DESIGN
REFER TO HR1000A

ORDERING INFORMATION

Part Number*	Package	Top Marking
HR1000HS	SOIC16	HR1000

* For Tape & Reel, add suffix -Z (e.g. HR1000HS-Z).
 For RoHS compliant packaging, add suffix -LF (e.g. HR1000HS-LF-Z)

PACKAGE REFERENCE

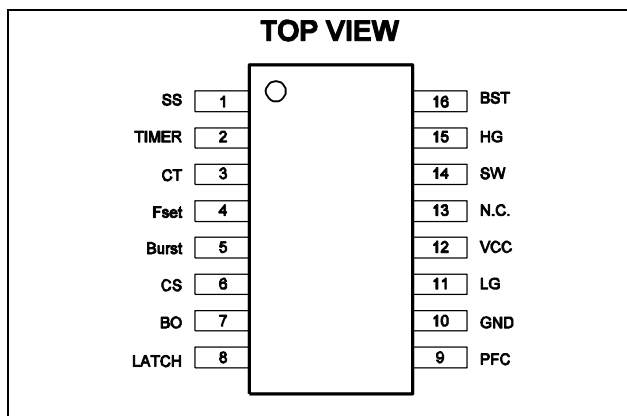

ABSOLUTE MAXIMUM RATINGS ⁽¹⁾

Symbol	Pin	Parameter	Value	Unit
V _{BST}	16	Floating Supply Voltage	-1 to 618	V
V _{SW}	14	Floating Ground Voltage	-8 to V _{BST} -18	V
dV _{SW} /dt	14	Floating Ground Max. Slew Rate	50	V/ns
V _{CC}	12	IC Supply Voltage (I _{CC} <25mA)	Self-limited	V
V _{PFC}	9	Maximum Voltage (pin open)	-0.3 to V _{CC}	V
I _{PFC}	9	Maximum Sink Current (pin low)	Self-limited	A
I _{Fset}	4	Maximum Source Current	2	mA
LG	11	Maximum Voltage	-0.3 to 16	V
	1 to 8	Analog Inputs and Outputs	-0.3 to 6	V
P _{IC}		Continuous Power Dissipation (T _A = +25°C) ⁽²⁾	1.56	W
T _J		Junction Temperature	150	°C
T _{Lead}		Lead Temperature (Solder)	260	°C
T _{Storage}		Storage Temperature	-55 to +150	°C

Recommended Operating Conditions ⁽³⁾

Supply Voltage V_{CC} 13V to 15.5V
 Analog inputs and outputs -0.3V to 6.5V
 Operating Junction Temp (T_J) . -40°C to + 125°C

Thermal Resistance ⁽⁴⁾ θ_{JA} θ_{JC}
 SOIC16.....80.....35 ... °C/W

Notes:

- Exceeding these ratings may damage the device.
- The maximum allowable power dissipation is a function of the maximum junction temperature T_J(MAX), the junction-to-ambient thermal resistance θ_{JA} , and the ambient temperature T_A. The maximum allowable continuous power dissipation at any ambient temperature is calculated by D(MAX)=(T_J(MAX)-T_A)/ θ_{JA} . Exceeding the maximum allowable power dissipation will cause excessive die temperature, and the regulator will go into thermal shutdown. Internal thermal shutdown circuitry protects the device from permanent damage.
- The device is not guaranteed to function outside of its operating conditions.
- Measured on JESD51-7, 4-layer PCB.

ELECTRICAL CHARACTERISTICS
 $T_J=25^{\circ}\text{C}$, $V_{CC}=13\text{V}$, $C_{HG}=C_{LG}=1\text{nF}$; $C_T=470\text{pF}$, $R_{Fset}=12\text{k}\Omega$, unless otherwise specified.

Parameter	Pin	Symbol	Min	Typ	Max	Unit
IC Supply Voltage (VCC)						
VCC Operating Range	12		8.9		15.5	V
VCC High Threshold, IC Switch-on	12	V_{CCH}	11.6	12.3	13	V
VCC Low Threshold, IC Switch-off	12	V_{CCL}	7.5	8.2	8.9	V
Hysteresis	12	V_{hys}		4.1		V
VCC Clamp Current during Fault Condition ($V_{CC}=16\text{V}$, Latch=2V)	12	I_{Clamp}		6		mA
VCC Clamp Voltage during Fault Condition ($V_{CC}>16\text{V}$ or $V_{LATCH}>1.85\text{V}$ or $V_{CS}>1.5\text{V}$ or $V_{TIMER}>3.5\text{V}$ or $V_{BO}<1.25\text{V}$ or $V_{BO}>5.5\text{V}$ or OTP)	12	V_{Clamp}		14.3		V
IC Supply Current (VCC)						
Start-up Current (Before the device turns on, $V_{CC}=V_{CCH}-0.2\text{V}$)	12	$I_{start-up}$		250	300	μA
Quiescent Current (Device on, $V_{Burst}=1\text{V}$)	12	I_q		1.5	2	mA
Operating Current (Device on, $V_{Burst}=V_{Fset}$)	12	I_{op}		3	5	mA
Residual Consumption ($V_{CC}>16\text{V}$ or $V_{CC}<8\text{V}$ $V_{LATCH}>1.85\text{V}$ or $V_{CS}>1.5\text{V}$ or $V_{TIMER}>3.5\text{V}$ or $V_{BO}<1.25\text{V}$ or $V_{BO}>5.5\text{V}$ or OTP)	12	I_r		350	400	μA
High-side Floating-gate-driver Supply (BST, SW)						
BST pin Leakage Current ($V_{BST}=600\text{V}$)	16	I_{LKBST}			10	μA
SW pin Leakage Current ($V_{SW}=582\text{V}$)	14	I_{LKSW}			10	μA
Over-current Comparator (CS)						
Input Bias Current ($V_{CS}=0$ to $V_{CSlatch}$)	6	I_{CS}			1	μA
Leading-edge Blanking	6	t_{LEB}		250		ns
Frequency Shift Threshold	6	V_{CSs}	0.75	0.8	0.85	V
Latch-off Threshold	6	$V_{CSlatch}$	1.41	1.5	1.59	V
Line Voltage Sensing (BO)						
Threshold Voltage	7	V_{th}	1.2	1.25	1.3	V
Clamp Level	7	V_{clamp}	5.1	5.5	5.8	V
Current Hysteresis ($V_{CC}>5\text{V}$, $V_{BO}=0.3\text{V}$)	7	I_{Hyst}	9	12	15	μA
Latch Function (LATCH)						
Input Bias Current ($V_{LATCH}=0$ to V_{th})	8	I_{LATCH}			1	μA
LATCH Threshold	8	V_{th}	1.75	1.85	1.95	V
Oscillator						
Output Duty Cycle		D	48	50	52	%
Oscillation Frequency		f_{osc}			600	kHz
Dead-time		t_D	300	350	400	ns
CT Peak Value	3	V_{CFp}		3.8		V
CT Valley Value	3	V_{CFv}		0.9		V
Voltage Reference at Fset pin	4	V_{REF}	1.92	2	2.08	V

ELECTRICAL CHARACTERISTICS (continued)
 $T_J=25^{\circ}\text{C}$, $V_{CC}=13\text{V}$, $C_{HG}=C_{LG}=1\text{nF}$; $C_T=470\text{pF}$, $R_{Fset}=12\text{k}\Omega$, unless otherwise specified.

Parameter	Pin	Symbol	Min	Typ	Max	Unit
PFC Function (PFC)						
Low Saturation Level ($I_{PFC}=1\text{mA}$, $V_{LATCH}=2\text{V}$)	9	V_L			0.2	V
Soft Start Function (SS)						
Discharge Resistance ($V_{CS}>V_{CSx}$)	1	R		120		Ω
Standby Function (Burst)						
Disable Threshold	5	V_{th}	1.18	1.23	1.28	V
Hysteresis	5	V_{hys}		100		mV
Delayed Shutdown (TIMER)						
Charge Current ($V_{TIMER}=1\text{V}$, $V_{CS}=0.85\text{V}$)	2	I_{CHARGE}	80	130	180	μA
Threshold for forced Operation at Maximum Frequency	2	V_{th1}	1.88	2	2.08	V
Shut Down Threshold	2	V_{th2}	3.3	3.5	3.7	V
Restart Threshold	2	V_{th3}	0.25	0.3	0.35	V
Low-side Gate Driver (LG, referenced to GND)						
Peak Source Current	11	$I_{sourcepk}$	1.5			A
Peak Sink Current	11	I_{sinkpk}	2			A
Sourcing Resistor	11	R_{source}		4		Ω
Sinking Resistor	11	R_{sink}		2		Ω
Fall Time	11	t_f		20		ns
Rise Time	11	t_r		20		ns
UVLO Saturation ($V_{CC}=0$ to V_{CCH} , $I_{sink}=2\text{mA}$)	11				1.1	V
High Side Gate Driver (HG, referenced to SW)						
Peak Source Current	15	$I_{sourcepk}$	1.5			A
Peak Sink Current	15	I_{sinkpk}	2			A
Sourcing Resistor	15	R_{source}		4		Ω
Sinking Resistor	15	R_{sink}		2		Ω
Fall Time	15	t_f		20		ns
Rise Time	15	t_r		20		ns
Thermal Shutdown						
Thermal Shutdown Threshold				150		$^{\circ}\text{C}$
Thermal Shutdown Recovery Threshold				120		$^{\circ}\text{C}$

NOT RECOMMENDED FOR NEW DESIGN
REFER TO HR1000A

TYPICAL PERFORMANCE CHARACTERISTICS

Supply Current vs. Supply Voltage

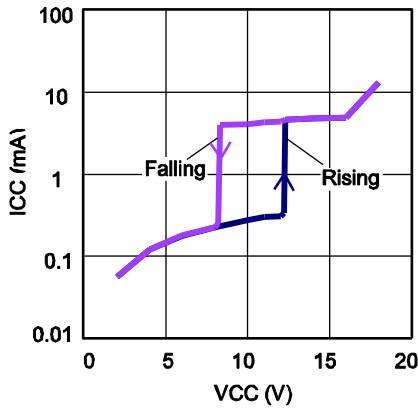
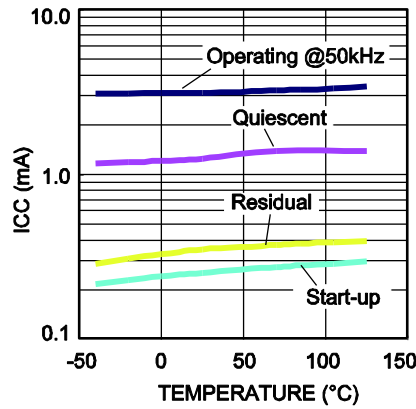
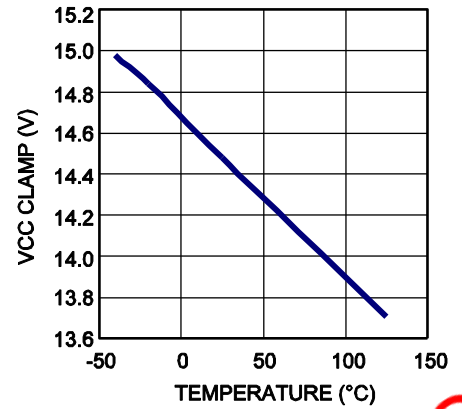
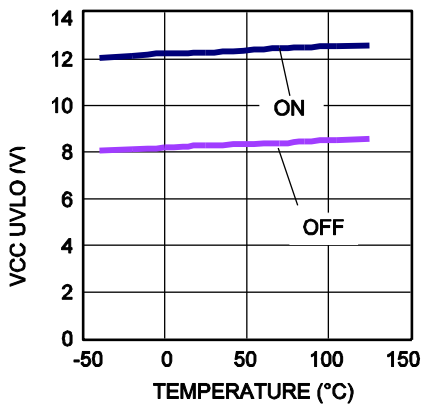
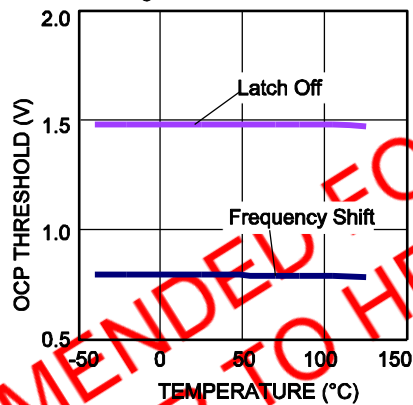
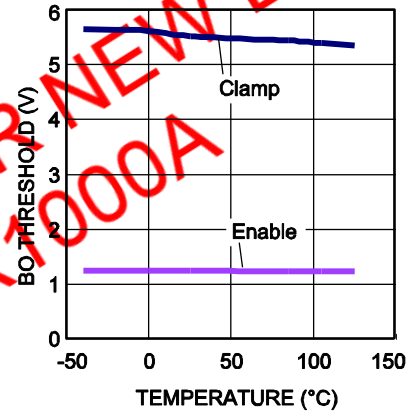
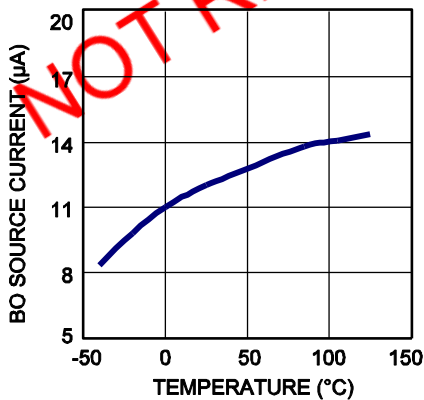
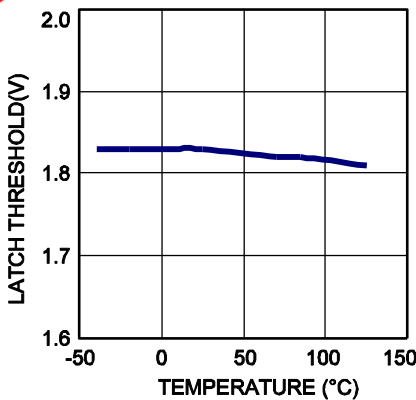
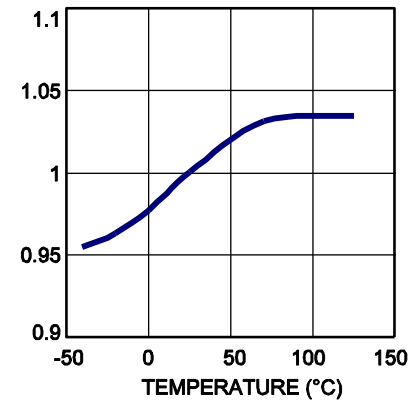

 Supply Current vs. T_J

 VCC Clamp Voltage vs. T_J

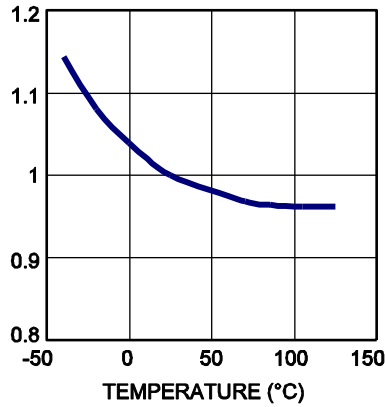
 VCC Threshold vs. T_J

 Current Sense Threshold vs. T_J

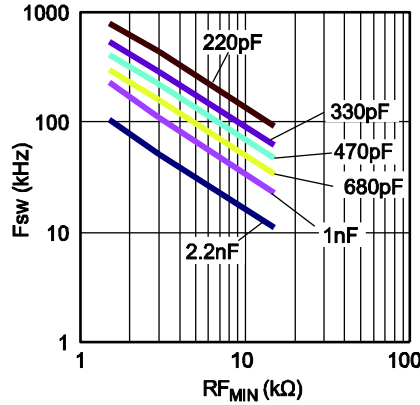
 BO Threshold vs. T_J

 BO Source Current vs. T_J

 Latch Threshold vs. T_J

 Oscillator Frequency vs. T_J

TYPICAL PERFORMANCE CHARACTERISTICS (continued)

Dead-time vs. T_J



Oscillator Frequency vs. Frequency-Set Resistance



Oscillator Ramp vs. T_J

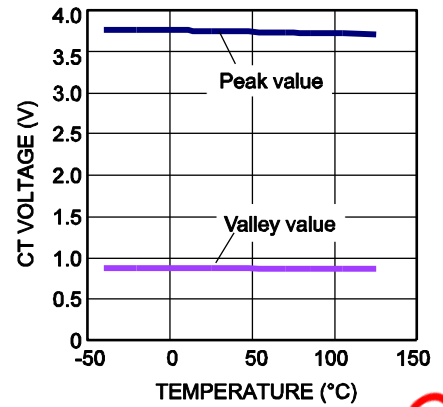

Current Mirror Ratio vs. T_J

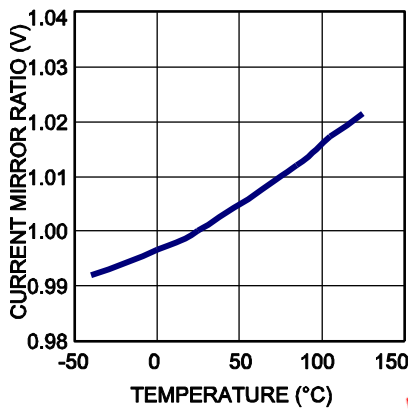

Reference Voltage vs. T_J

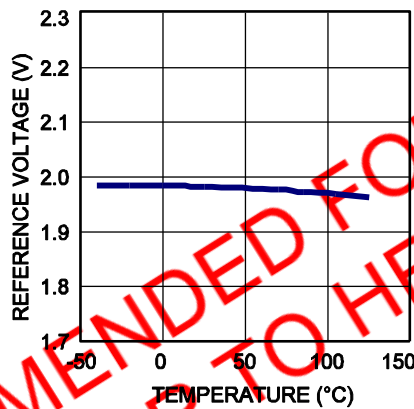

Standby Threshold vs. T_J

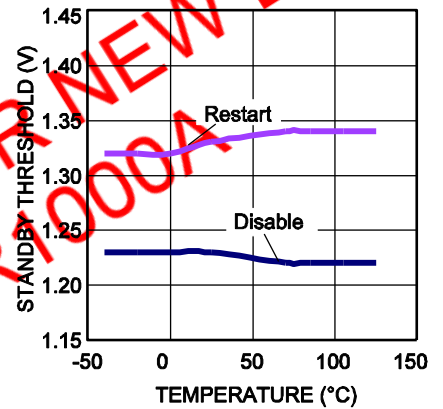

Delay Shutdown Charge Current vs. T_J

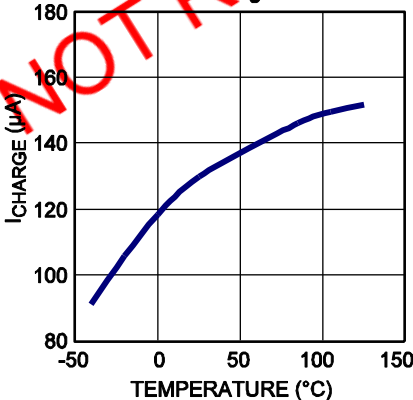

OCP Delay Threshold vs. T_J

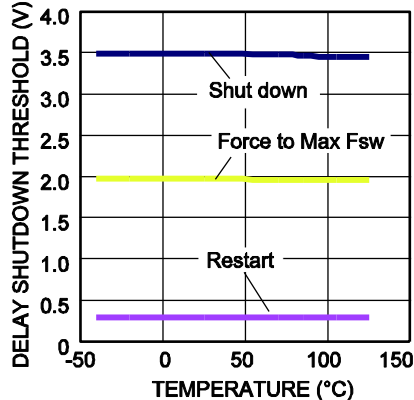

TYPICAL PERFORMANCE CHARACTERISTICS *(continued)*

Performance waveforms are generated using the evaluation board built with design example on page 20. $V_{AC}=230V$, $V_{out}=12V$, $I_{out}=8A$, $T_A=25^{\circ}C$, unless otherwise noted.

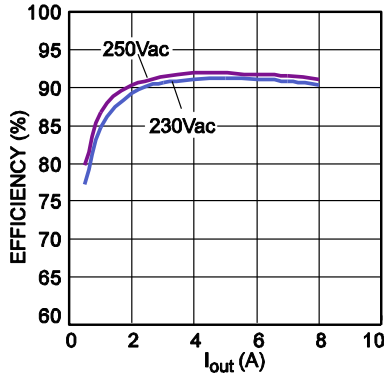
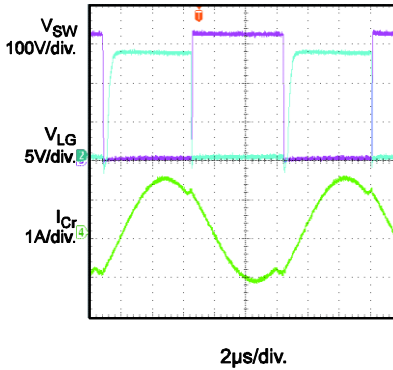
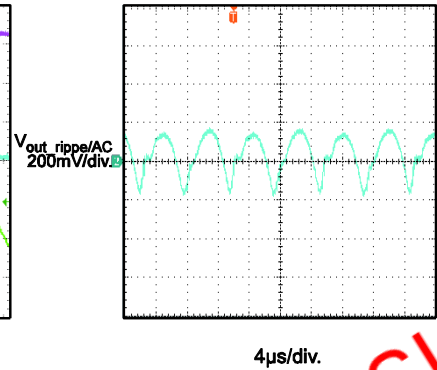
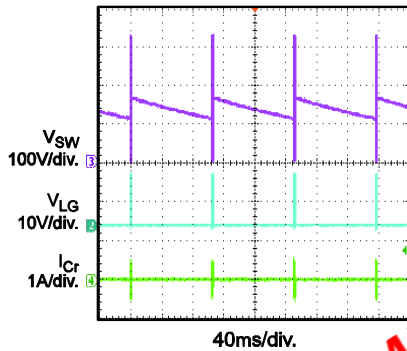
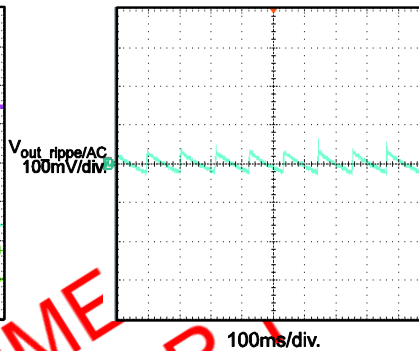
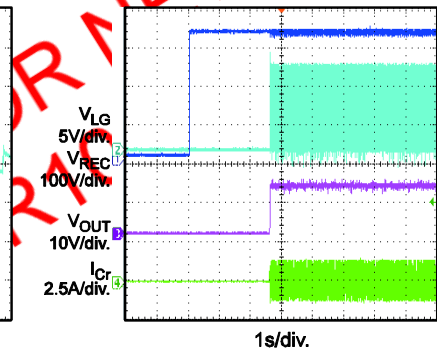
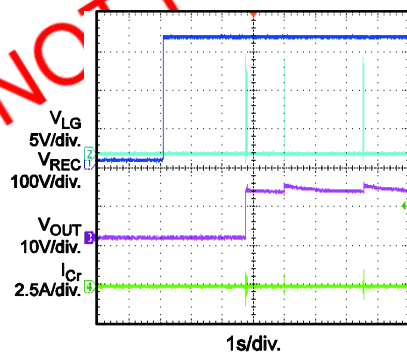
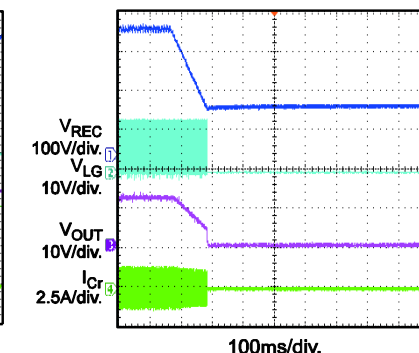
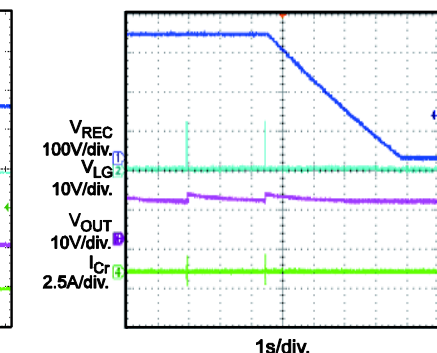
Efficiency

Steady State
 $V_{out}=12V$, $I_{out}=8A$

Steady State
 $V_{out}=12V$, $I_{out}=8A$

Steady State
 $V_{out}=12V$, $I_{out}=0A$

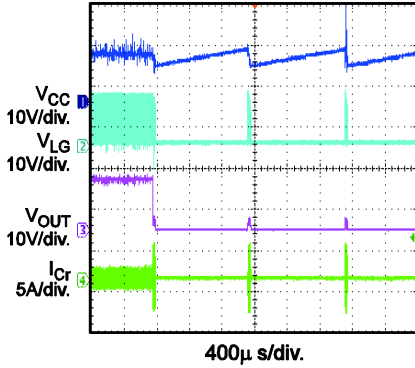
Steady State
 $V_{out}=12V$, $I_{out}=0A$

Start-up
 $V_{out}=12V$, $I_{out}=8A$

Start-up
 $V_{out}=12V$, $I_{out}=8A$

Shutdown
 $V_{out}=12V$, $I_{out}=8A$

Shutdown
 $V_{out}=12V$, $I_{out}=0A$

TYPICAL PERFORMANCE CHARACTERISTICS *(continued)*

Performance waveforms are generated using the evaluation board built with design example on page 20. V_{AC}=230V, V_{out}=12V, I_{out}=8A, T_A=25°C, unless otherwise noted.

SCP Entry
V_{out}=12V, I_{out}=8A



SCP Entry
V_{out}=12V, I_{out}=0A

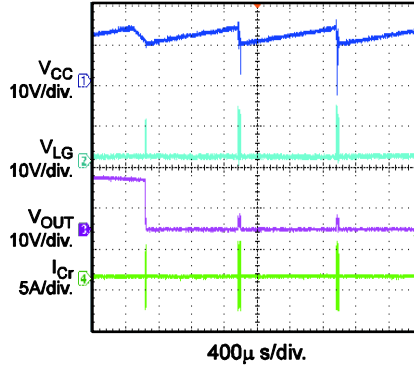

Start-up with Short Circuit
V_{out}=12V

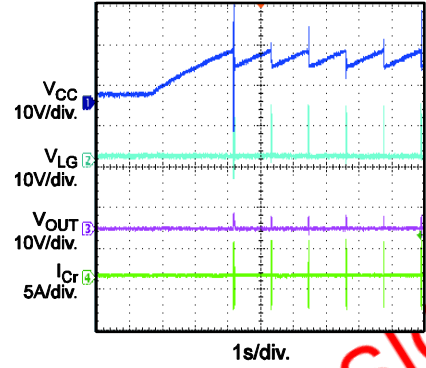

**NOT RECOMMENDED FOR NEW DESIGN
REFER TO HR1000A**

PIN FUNCTIONS

Pin #	Name	Description
1	SS	Soft-start. Connect an external capacitor with this pin to GND and a resistor to Fset pin to set the maximum oscillator frequency and the time constant for the frequency shift during start-up. An internal switch discharges the capacitor when the chip turns off ($VCC < UVLO$, $VCC > 16V$, $BO < 1.25V$ or $> 5.5V$, $LATCH > 1.85V$, $CS > 1.5V$, $TIMER > 2V$, thermal shutdown) to guarantee soft-start when the current sense pin voltage exceeds 0.8V, and as long as it stays above 0.75V.
2	TIMER	Period between over-current and shutdown. Connect a capacitor and a resistor from this pin to GND to set both the maximum duration from an over-current condition before the IC stops switching, and the delay before the IC resumes switching. Each time the CS pin voltage exceeds 0.8V, an internal 130 μ A source charges the capacitor; an external resistor slowly discharges this capacitor. If the pin voltage 2V, the soft-start capacitor discharges completely, pushing the switching frequency to its maximum value; the 130 μ A source remains on. When the voltage exceeds 3.5V the IC stops switching and the internal current source turns off so that the pin voltage decays. The IC enters soft-started when the voltage drops below 0.3V. This allows the converter to work intermittently with very low average input power under short-circuit conditions.
3	CT	Time-Set. An internal current source programmed by the external network connected to pin 4 charges and discharges a capacitor connected to GND. Determines the convert switching frequency.
4	Fset	Switching Frequency Set. Provides a precise 2V reference. A resistor connected from this pin to GND defines a current that sets the minimum oscillator frequency. Connect the phototransistor of an opto-coupler to this pin through a resistor to close the feedback loop that modulates the oscillator frequency to regulate the converter output voltage. The value of this resistor will set the maximum operating frequency. An R-C series connected from this pin to GND sets frequency shift at start-up to prevent excessive energy inrush (soft-start).
5	Burst	Burst-Mode Operation Threshold. The pin senses some voltage related to the feedback control, which is compared to an internal reference (1.25V). If the voltage on the pin is lower than the reference, the IC enters an idle state and reduces its quiescent current. The chip resumes switching when the voltage exceeds the reference by 50mV. Soft-start is not invoked. This function enables burst-mode operation when the load falls below a programmed level, determined by connecting an appropriate resistor to the opto-coupler to pin Fset (see block diagram). Tie the pin to Fset if burst-mode is not used.
6	CS	Primary-Current Sense. Uses a sense resistor or a capacitive divider to sense the primary current. The voltage signal requires an averaging filter because this input is not intended for cycle-by-cycle control. As the voltage exceeds a 0.8V threshold (with 50mV hysteresis), the soft-start capacitor on pin 1 discharges internally: The frequency increases, limiting the power throughput. Under an output short circuit, this normally results in a nearly-constant peak-primary current. A timer set on pin 2 limits the duration of this condition. If the current continues to build up despite the frequency increase, a second comparator referenced at 1.5V latches the device off and brings its consumption up to about pre-start-up levels. The information is latched, requiring cycling the IC supply voltage to restart: The latch is removed as the VCC voltage drops below the UVLO threshold. Tie the pin to GND if the function is not used.

PIN FUNCTIONS (continued)

Pin #	Name	Description
7	BO	Input Voltage Sense. Connect to the high-voltage input bus through the tap of a resistor divider to perform either AC or DC (in systems with PFC) brownout protection. A voltage below 1.25V shuts down (without latching) the IC, lowers its consumption and discharges the soft-start capacitor. The IC operation resumes (with soft-start) when the voltage exceeds 1.25V. The comparator has current hysteresis: An internal 12 μ A current source is ON as long as the applied voltage is below 1.25V, and is OFF if this value is exceeded. Bypass the pin with a capacitor to GND to reduce noise pick-up. An internal Zener diode top-limits the pin voltage. Activating the Zener diode causes the IC to shut down (without latching). Bias the pin between 1.25V and 5.5V if the function is not used.
8	LATCH	IC Latch. Connects internally to a comparator that—when the pin voltage exceeds 1.85V—shuts the IC down and brings its consumption to near pre-start-up levels. The latch is removed as the VCC voltage goes below the UVLO threshold. Tie the pin to GND if the function is not used.
9	PFC	Interface to the front-end PFC. This pin—normally high—stops the PFC controller for protection purposes or during burst-mode operation. It goes low when the IC shuts down from the following conditions: VCC > 16V, LATCH > 1.85V, CS > 1.5V, BO > 5.5V, thermal shutdown and BURST < 1.25V. The pin also goes low when the voltage on TIMER exceeds 2V, and goes back open as the voltage falls below 0.3V. During UVLO, it is open. Leave the pin unconnected if not used.
10	GND	Ground. Current return for both the low-side gate-driver current and the IC bias current. Tie all bias component ground connections to a trace to this pin. Keep separate from any pulsed current return.
11	LG	Low-Side Gate Driver. The driver is capable of a minimum 0.5A source and a minimum 1A sink-peak current to drive the lower MOSFET of the half-bridge leg. The pin is actively pulled to GND during UVLO.
12	VCC	Supply Voltage. Supplies both the IC signal and the low-side gate driver. Sometimes a small bypass capacitor (e.g., 0.1 μ F) can help provide a clean bias voltage for the IC signal.
13	N.C.	High-Voltage Spacer. Not internally connected—isolates the high-voltage pin and eases compliance with safety regulations (creepage-distance) on the PCB.
14	SW	High-Side Switch Source. Current return for the high-side gate-drive current. Requires careful layout to avoid large spikes below ground.
15	HG	High-Side Floating Gate-Driver. Capable of minimum 0.5A source and minimum 1A sink-peak current to drive the upper MOSFET of the half-bridge leg. An internal resistor connected to pin 14 (SW) ensures that the pin does not floating during UVLO.
16	BST	High-Side Gate Driver for Floating Voltage Supply. Connect a bootstrap capacitor between this pin and pin 14 (SW)—fed by an internal bootstrap diode driven in-phase with the low-side gate-drive.

BLOCK DIAGRAM

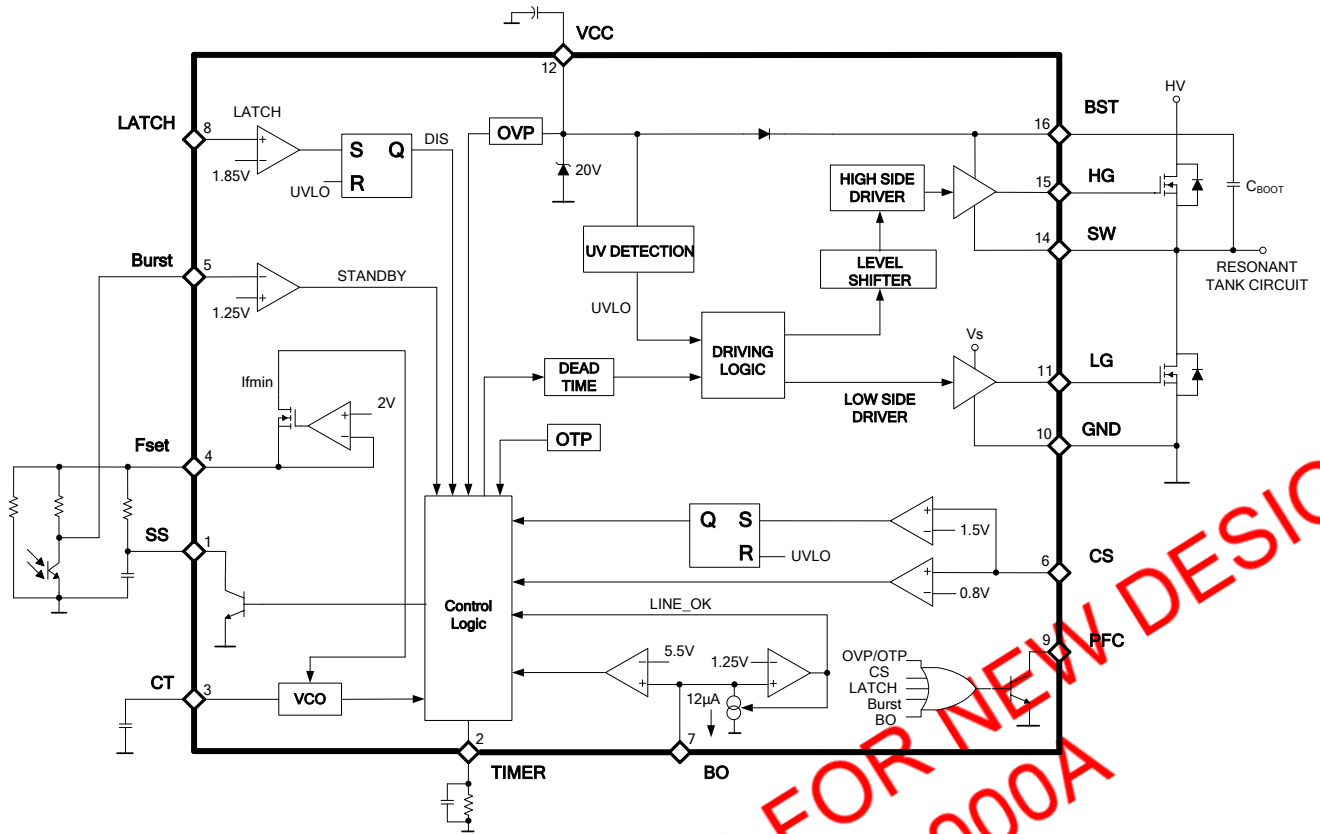

Figure 1: Functional Block Diagram

NOT RECOMMENDED FOR NEW DESIGN
REFER TO HR1000A

FUNCTIONAL DESCRIPTION

Oscillator

The charge/discharge time of the CT capacitor determines the oscillator frequency. The voltage on the CT capacitor fluctuates between the peak threshold and valley threshold to form a triangle waveform. Figure 2 shows the detailed waveform during steady state.

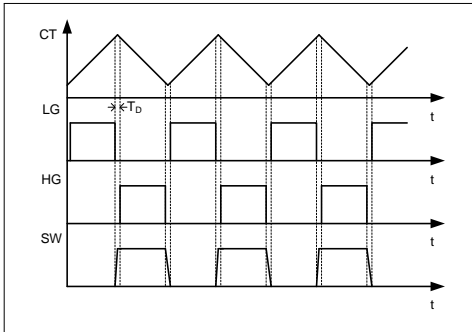

Figure 2: CT Waveform and Gate Signal

The network connecting the Fset pin charges/discharges the current on the CT capacitor, as Figure 3 shows. The source current of the Fset pin controls the current

source-1 (I_{S-1}) to charge the CT capacitor. Here, the current mirror ratio inside the HR1000 is 1A/A. When a switching cycle starts, I_{S-1} charges the CT capacitor until the voltage triggers the peak threshold voltage. Then the discharge current source (I_{S-2}) with twice the source current of the Fset pin turns on. Therefore, the CT capacitor discharges with the source current of the Fset pin. When the voltage on the CT capacitor drops to the valley threshold voltage, the I_{S-2} turns off and then a new switching cycle is enabled.

Based on the block diagram shown in Figure 3, the Fset RC network functions as described:

1. $R_{f_{min}}$ from the Fset pin to GND sets the maximum resistance of external RC network when the phototransistor is blocked, therefore setting the Fset minimum source current, which sets the minimum switching frequency;

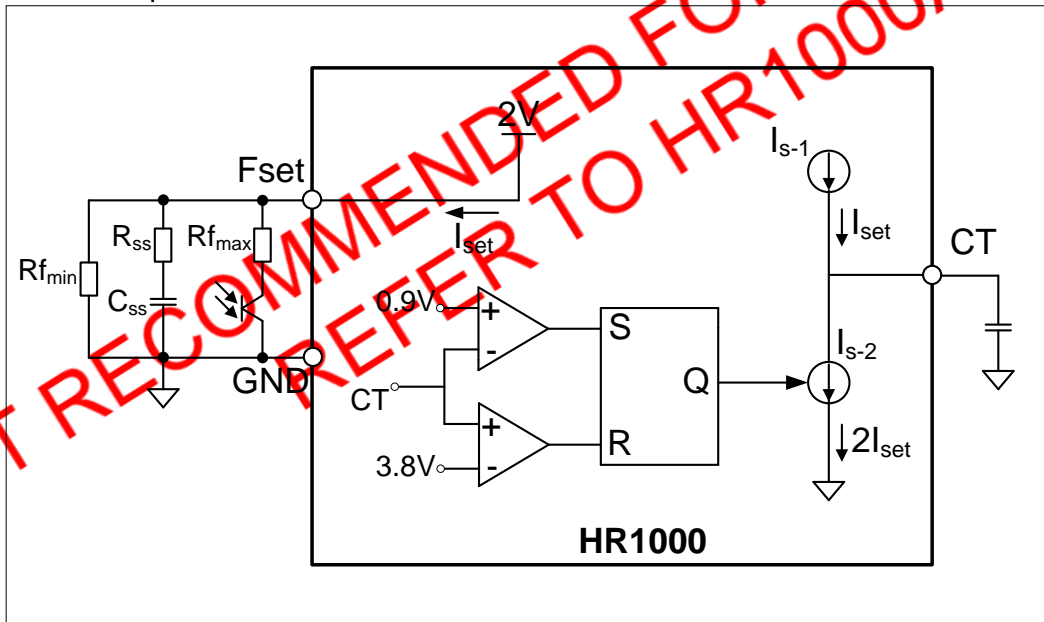

Figure 3: Oscillator Block Diagram

- Under normal operation, the phototransistor modulates the current flow through $R_{f_{max}}$ to modulate the frequency for output voltage regulation. When the phototransistor is saturated, the current flow through $R_{f_{max}}$ is at its maximum, setting the frequency at its maximum
- A series RC circuit connected between Fset and GND determines the frequency shift at start-up. (Please see the soft-start section for details.)

Based on the previous principles, the following equations describe the minimum and maximum frequency:

$$f_{min} = \frac{1}{3 \cdot CT \cdot R_{f_{min}}}$$

$$f_{max} = \frac{1}{3 \cdot CT \cdot (R_{f_{min}} \parallel R_{f_{max}})}$$

Typically, the CT capacitance is between 0.1nF and 1nF, so the values of $R_{f_{min}}$ and $R_{f_{max}}$ are:

$$R_{f_{min}} = \frac{1}{3 \cdot CT \cdot f_{min}}$$

$$R_{f_{max}} = \frac{R_{f_{min}}}{\frac{f_{max}}{f_{min}} - 1}$$

For the CT capacitance selection, here is a note for low temperature and high switching frequency application: when the temperature is low, the source current capability of Fset pin drops a little due to the property of internal transistor circuit, which means there might be not big enough current to charge/discharge the large CT capacitor. So a small CT cap ($\leq 330\text{pF}$) is recommended for such application.

Burst-Mode Operation

Under light-load or in the absence of a load, the maximum frequency limits the resonant half-bridge switching frequency. To control the output voltage and limit power consumption, the HR1000 can enable compatible converters to operate in burst-mode to sharply reduce the average switching frequency, thus reducing the average residual magnetizing current and the associated losses.

Operating in burst-mode requires setting the Burst pin on the HR1000; if the voltage on the

Burst pin drops below 1.25V, HR1000 will shut down the HG and LG gate drive outputs, leaving only the 2V reference voltage on the Fset pin and the SS pin to retain the previous state and minimize HR1000's power consumption. When the voltage on the Burst pin exceeds 1.25V by 50mV, HR1000 resumes normal operation.

Based on the Burst-mode operating principle, the Burst pin voltage must connect to the feedback loop. Figure 4 shows a typical circuit connect the Burst pin to the feedback signal for narrow-input-voltage range applications:

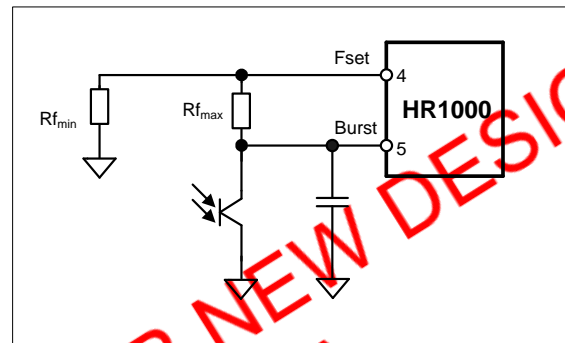

Figure 4: Burst-Mode Operation Set-Up

In addition to setting the oscillator, $R_{f_{max}}$ also determines the maximum switching frequency that HR1000 operates in burst-mode. After confirming f_{max} , calculate $R_{f_{max}}$ as below:

$$R_{f_{max}} = \frac{3}{8} \cdot \frac{R_{f_{min}}}{\frac{f_{max}}{f_{min}} - 1}$$

Here, f_{max} corresponds to a load point, P_{Burst} , where the peak current flow through the transformer is too low to cause audible noise.

The above introduction is based on a narrow input voltage range. As a property of the resonant circuit, input voltage also determines the switching frequency. That means the P_{Burst} has a large variance over the wide input voltage range. To stabilize P_{Burst} over the input range, use the circuit in Figure 5 to insert the input voltage signal into feedback loop.

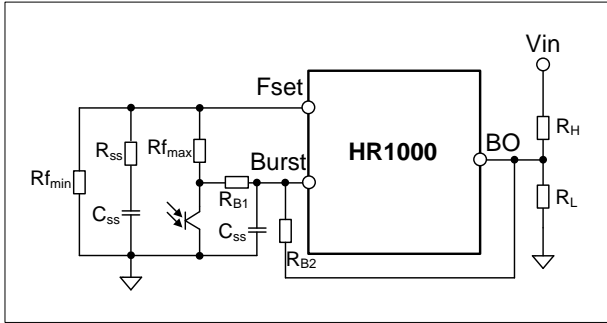

Figure 5: Bust-mode Operation Set-up for Wide Input Voltage Range

R_{B1} and R_{B2} from Figure 5 correct against the wide input voltage range. Select both resistors based on experimental results. Note that the total resistance of R_{B1} and R_{B2} should be much bigger than R_H to minimize the effect on the BO pin voltage.

During burst-mode operation, when the load is lower than P_{Burst} , the switching frequency is clamped at the maximum frequency. Then the output voltage must rise over the set value, which would increase the current flowing through the opto-coupler. Therefore, the voltage on $R_{f_{max}}$ must rise due to the increased opto-transistor current. The Burst pin voltage would then drop below 1.25V, triggering the gate signal OFF state. Until the output voltage falls below the setting value, the current flow through opto-coupler then decreases, causing the Burst pin voltage to rise. When the voltage exceeds $1.25V + 100mV$, the IC will restart to generate the gate signal. The IC will continue to operate in this mode under no-load or light-load to decrease average power consumption.

PFC-Disable Function

Many applications require a PFC function, making a pre-regulator widely before a resonant circuit common. Under some conditions—e.g. no-load or light load, OCP, OVP—require disabling the PFC .

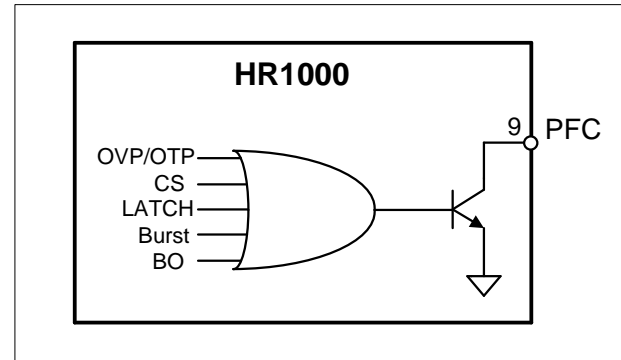

Figure 6: PFC Disable Block Diagram

The HR1000 provide PFC disabling. Pull the PFC pin low for one of following conditions:

- Gate-off during burst-mode ($Burst < 1.25V$);
- OCP ($CS > 1.5V$); input over-voltage ($BO > 5.5V$);
- Latch pin HIGH ($Latch > 1.85V$);
- TIMER pin voltage exceeding 2V without dropping to 0.3V;
- Over-temperature protection triggering.

Shutdown the PFC to reduce power consumption or to protect the system. Figure 7 shows the typical application circuit communicating between the HR1000 and the PFC controller.

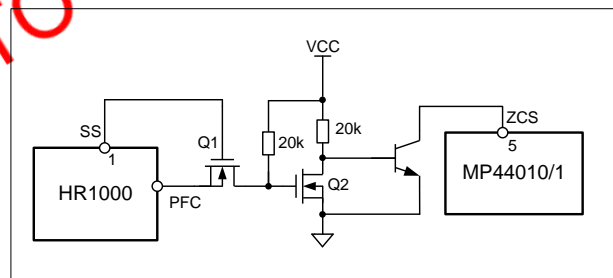

Figure 7: Communication Circuit between HR1000 and PFC Controller

If this function is not used, PFC pin can float.

Soft-Start Operation

For the resonant half-bridge converter, the power delivered is inversely proportional to the switching frequency. To achieve soft-start, start

the switching frequency with a high value until the value is controlled by the closed loop.

The converter + HR1000 can easily achieve soft-start using an external RC series circuit as shown in Figure 8.

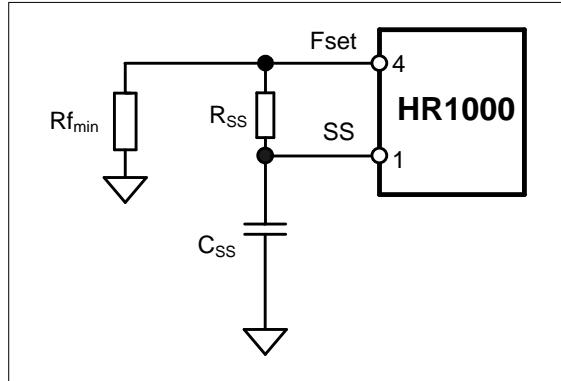

Figure 8: Soft-Start Block

When start-up begins, the SS voltage is 0V, so the soft-start resistor (R_{SS}) is in parallel to $R_{f_{min}}$. $R_{f_{min}}$ and R_{SS} determine the initial frequency as:

$$f_{start} = \frac{1}{3 \cdot CT \cdot (R_{f_{min}} || R_{SS})}$$

During start-up, the C_{SS} charges until its voltage reaches the reference -2V, and the current flow through R_{SS} drops to zero. This period takes about $5 \times (R_{SS} \times C_{SS})$. During this period, the switching frequency changes following an exponential curve: the C_{SS} charge initially decays relatively quickly but the rate progressively slows.

After this period ends, the output voltage is not still close to the setting value, so the feedback loop will take over start-up.

With soft-start, the input current increases gradually until the output voltage reaches the setting point with little overshoot.

Select the soft-start RC network as per the equations below:

$$R_{SS} = \frac{R_{f_{min}}}{\frac{f_{start}}{f_{min}} - 1}$$

$$C_{SS} = \frac{3 \cdot 10^{-3}}{R_{SS}}$$

Select an initial frequency, f_{start} , at least $4 \times f_{min}$. Select C_{SS} as a trade-off between the desired

soft-start operation and the OCP speed (see the next section for details).

Current Sensing

Figure 9 shows the current sense block diagram.

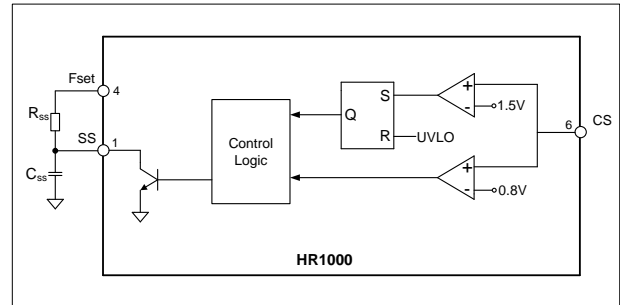

Figure 9: Current Sensing Block Diagram

There are two levels over-current protection.

The first level occurs when the CS voltage exceeds 0.8V, the comparator triggers the control logic to output a high-level control signal that turns on the transistor connecting SS and GND. Then the C_{SS} voltage drop results a sharp increase in oscillator frequency, and therefore reduces the energy transferred to the output. When the CS pin voltage drops back to 0.79V, the converter resumes normal operation with the help of the 10mV hysteresis.

Generally, the CS pin voltage continues to rise during a short circuit. The second level over-current protection triggers when the CS pin voltage rises to 1.5V. Then the IC is latched at very low consumption (residual consumption in EC table).

For two-level protection, a very large C_{SS} slows the discharge to the point that the transformer and the resonant inductor saturate and damages the secondary diode.

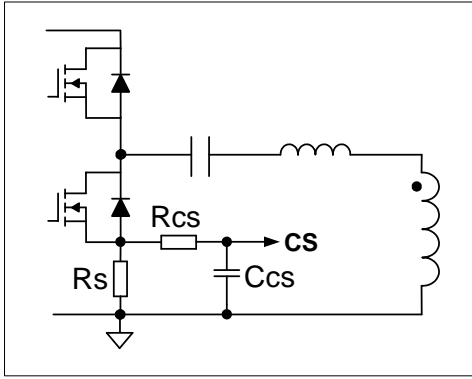

Figure 10: Current Sensing with a Sense Resistor

There are two types of current sensing methods: one uses a sense resistor in series with the low-side MOSFET; the other uses a lossless current-sensing network. The first method is simple but causes some unnecessary power consumption.

Calculate the sense resistor using the following equation:

$$R_s = \frac{4}{I_{Crpk}}$$

Where I_{Crpk} is the desired peak current through the primary MOSFET for the resonant capacitor at low input voltage and full load.

Since the circuit require an RC filter between the sensing resistor and CS pin, select an RC time constant at around $10/f_{min}$.

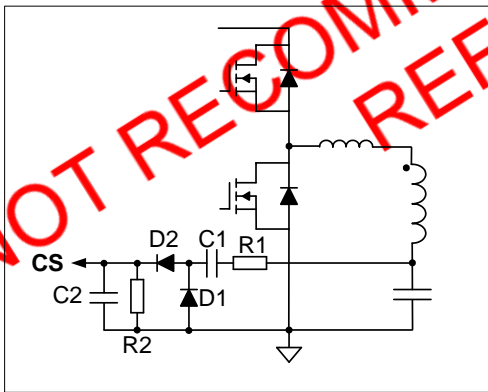

Figure 11: Current Sensing with Lossless Network

To design the lossless current sensing network, consider these two conditions:

1. R1 is smaller than several hundred ohms. The sensing network acts as a capacitive current divider. Use the equations below:

$$C1 \leq \frac{Cr}{100}$$

$$R2 = \frac{0.8 \cdot \pi}{I_{Crpk}} \cdot \left(1 + \frac{Cr}{C1}\right)$$

2. R1 is ~10kΩ. The sensing network acts to divide the ripple voltage on Cr. Design for this condition as per the equations below:

$$C1 \leq \frac{Cr}{100}$$

$$R2 = \frac{0.8 \cdot \pi}{I_{Crpk}} \cdot \frac{\sqrt{R1^2 + X_{C1}^2}}{X_{Cr}}$$

Calculating the reactance of C1 and Cr at the frequency where the maximum peak resonant current occurs. Empirically, the R2 and C2 time constant is about $10/f_{min}$.

Depending on the circuit, consider the calculated value as a cut value that requires adjustments based on experimental results to meet the design target.

The OCP can limit the energy transferred from the primary to the secondary during over-load or short-circuit period. However, excessive power consumption due to high continuous currents can damage the secondary-side windings and the rectifiers. The HR1000 provides additional protection to reduce the average power consumption during OCP: When OCP triggers, the converter enters a hiccup-like protection mode that operates intermittently.

Set the maximum over-load or short circuit operating time (t_{oc}) by selecting appropriate C_{Timer} and R_{Timer} . During the first OCP level when the CS voltage exceeds 0.8V, an internal 130μA current source turns on to charge C_{Timer} . When the voltage on C_{Timer} reaches 2V, the C_{SS} voltage drops below the OCP comparator output. This forces the switching frequency to equal f_{start} to minimize the transferred energy. t_{oc} is the time for the voltage on C_{Timer} to rise from 0V to 2V. However, there is no simple

relationship between t_{OC} and C_{Timer} . Select C_{Timer} based on experimental results (based on experiments: C_{Timer} may increase operating time by 100ms).

After the voltage on C_{Timer} rises to 2V, the 130uA current source continues to charge it until the voltage reaches the shutdown threshold (3.5V). This period is approximately:

$$t_{OP} = 10^4 \cdot t_{Timer}$$

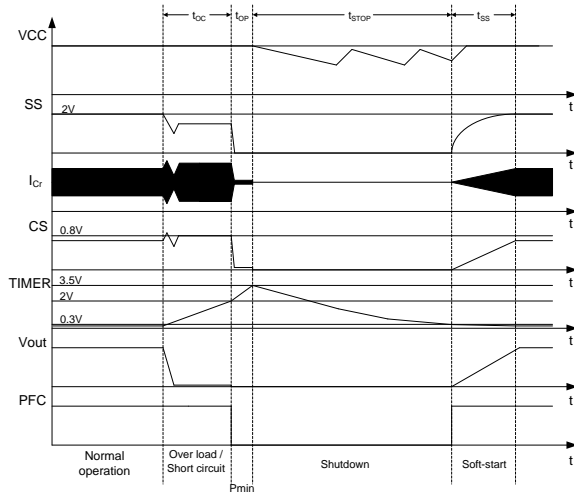

Figure 12: Delayed Shutdown and Soft-start Time Sequence

During this period, the switching frequency remains at f_{start} to limit the energy transferred. When the shutdown threshold triggers, the gate drive turns off and the 130uA current source shuts down. Then R_{Timer} slowly discharges C_{Timer} . This procedure lasts until the C_{Timer} voltage drops below 0.3V, then the IC restarts. This time period is:

$$t_{OFF} = R_{Timer} \cdot C_{Timer} \cdot \ln \frac{3.5}{0.3} \approx 2.5 R_{Timer} \cdot C_{Timer}$$

Figure 12 shows the operation's time sequence.

Latch Operation

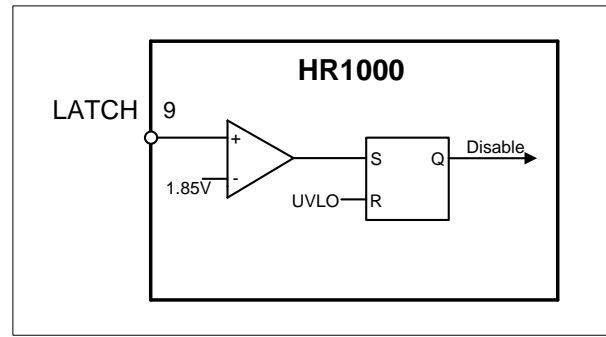

Figure 13: Latch Function Block

The HR1000 provides a simple latch-off function through the Latch pin. Applying an external voltage >1.85V causes the IC to enter a latched shutdown. After IC is latched, its consumption drops, as shown by the residual current in the EC table. Resetting the IC requires dropping the VCC voltage below the UVLO threshold.

The latch function implements accurate over-voltage protection by sensing the output voltage and converting it to an OVP signal via the opto-coupler.

Input Voltage Sensing

The HR1000 can stop when the input voltage drops below a specified value, and then restarted when the input voltage goes back to normal. This function guarantees that the resonant half-bridge converter always operates within the specified input voltage range. The IC senses voltage on BO through the tap of a resistor divider connected to the rectified AC voltage or the PFC output.

Figure 14 shows the line-sensing internal block diagram.

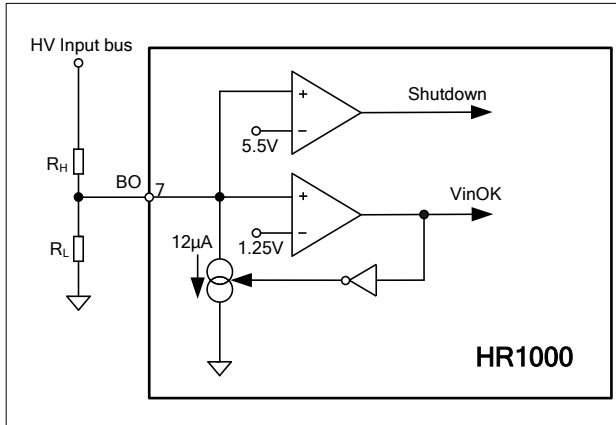
Figure 14: Input Voltage Sensing Block

The internal 12µA current source turns off when the BO voltage drops below 1.25V, and turns on when the BO voltage exceeds 1.25V. When the BO voltage drops below 1.25V, the IC shuts down the gate drive, and consumes very little power as per the residual current in the EC table. Calculate the input-voltage resistor divider with the desired ON (V_{inON}) and OFF (V_{inOFF}) input voltage as below:

$$R_H = \frac{V_{inON} - V_{inOFF}}{12 \cdot 10^{-6}}$$

$$R_L = R_H \cdot \frac{1.25}{V_{inOFF} - 1.25}$$

For additional protection, when the BO voltage exceeds the internal 5.5V clamp voltage, the IC will shutdown. When the BO voltage is between 1.25V and 5.5V, the IC will restart.

High-Side Gate Driver

The external BST capacitor provides energy to the high-side gate driver. An integrated bootstrap diode charges this capacitor through VCC. This diode simplifies the external driving circuit for the high-side switch, allowing the BST capacitor to charge when the low side MOSFET is on.

To provide enough gate driver energy and considering the BST capacitor charge time, use a 330nF-to-1µF capacitor for the BST capacitor.

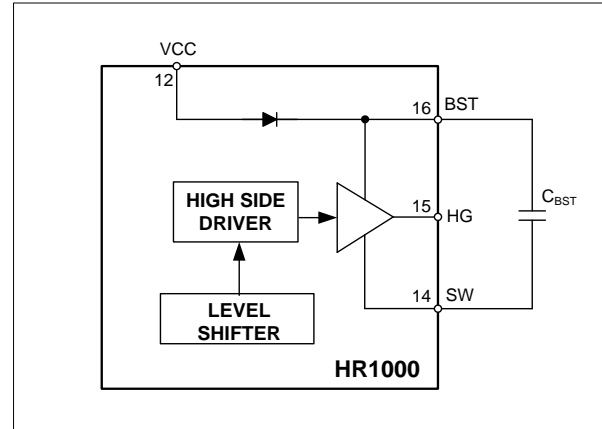
Figure 15: High-Side Gate Driver Low-Side Gate Drive

The LG pin provides the gate driver signal for the low-side MOSFET. The maximum absolute rating table shows that the maximum LG pin voltage is 16V. Under some conditions, a large voltage spike occurs on the LG pin due to oscillations from the long gate-driver wire, the MOSFET parasitic capacitance, and the small gate-driver resistor. This voltage spike is dangerous to the LG pin, so add a 15V Zener diode close to the LG and GND pins.

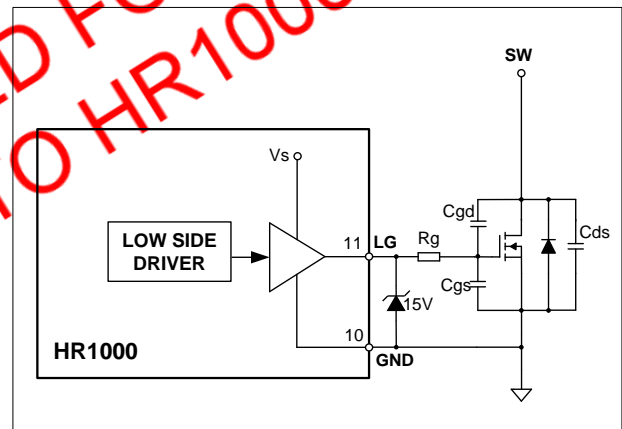
Figure 16: Low-Side Gate Driver

Design Example

Below is a design example following the specifications from the application guideline:

Input AC voltage	230-250VAC
Output voltage	12V
Output current	8A

Figure 17 shows the detailed application schematic. The typical performance and circuit waveforms have been shown in the Typical Performance Characteristics section.

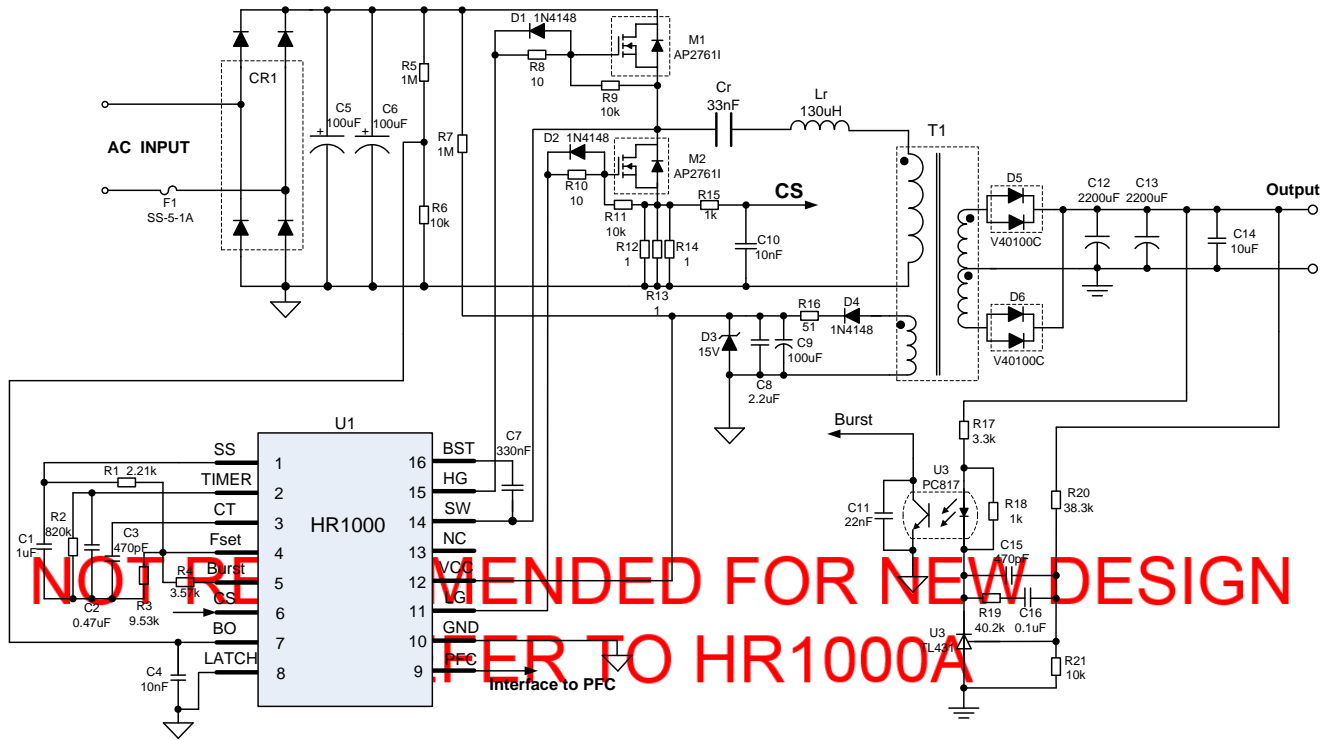
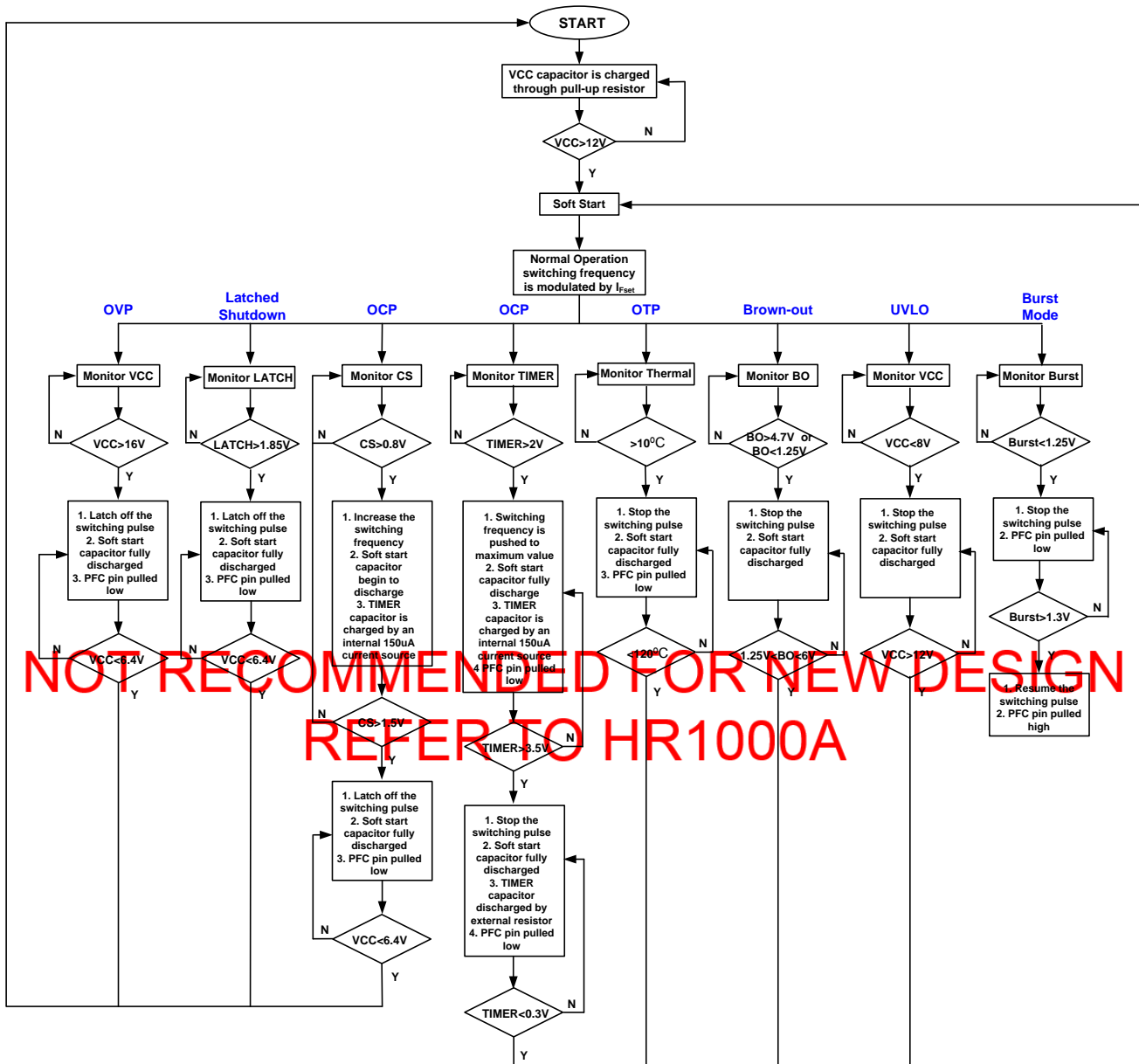
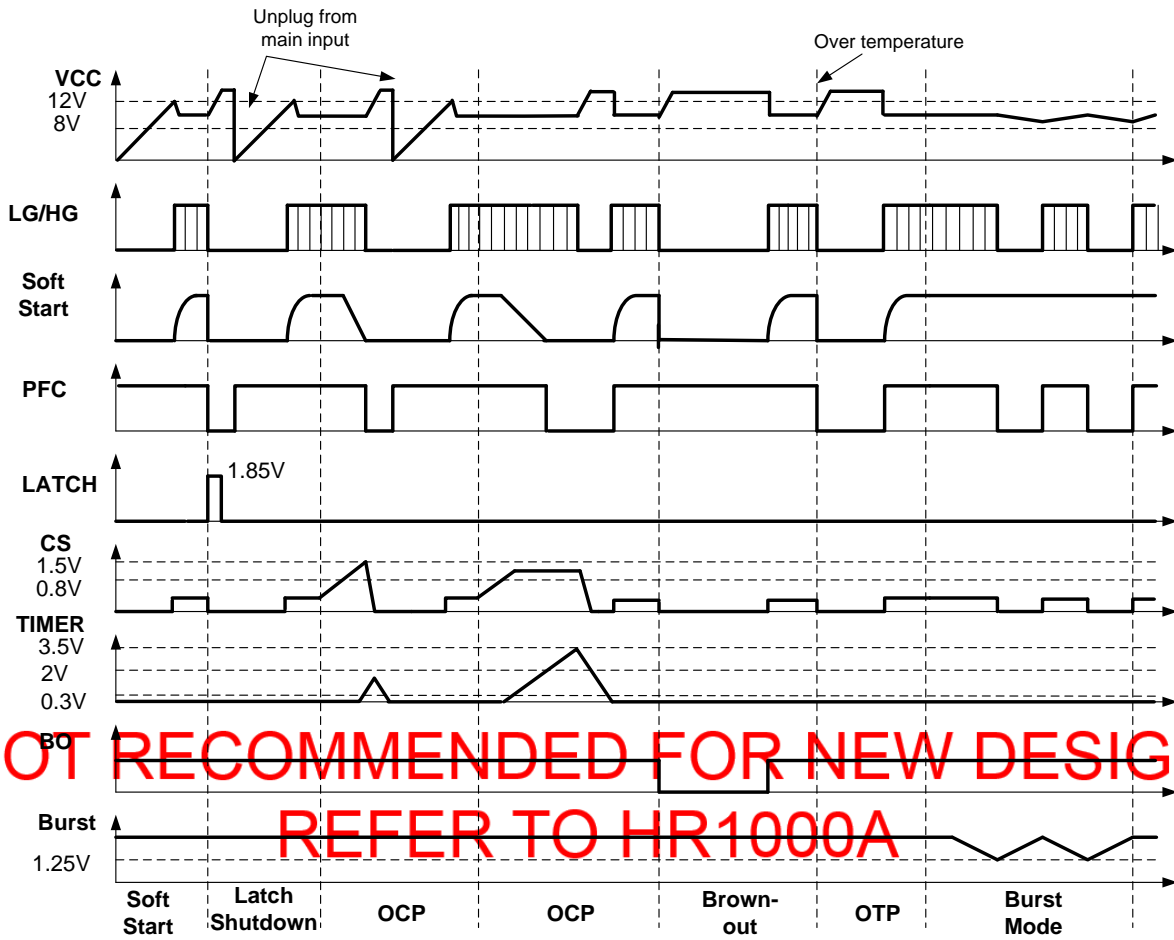

Figure 17: Design Example for 12V/8A Output

FLOW CHART



TYPICAL WAVEFORMS



NOT RECOMMENDED FOR NEW DESIGN
REFER TO HR1000A

PACKAGE INFORMATION

SOIC16

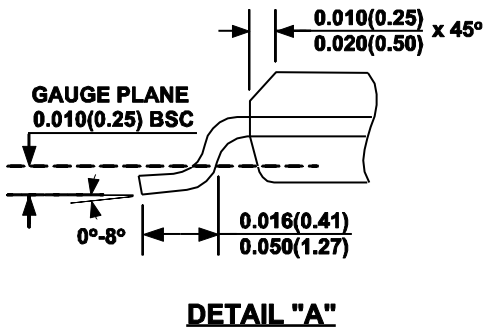
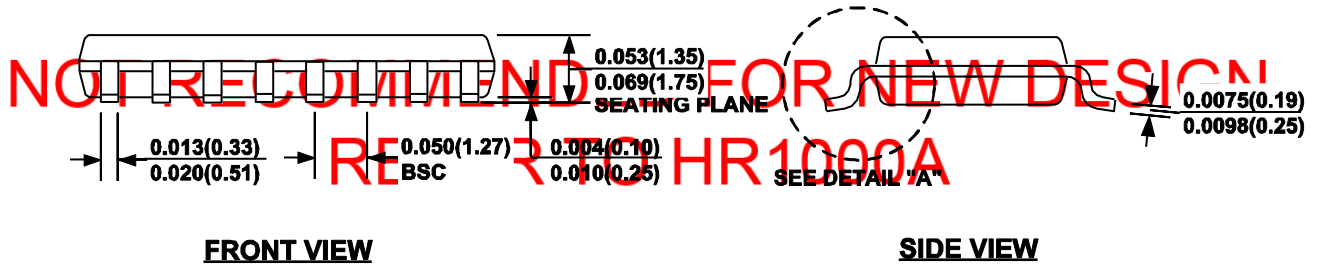
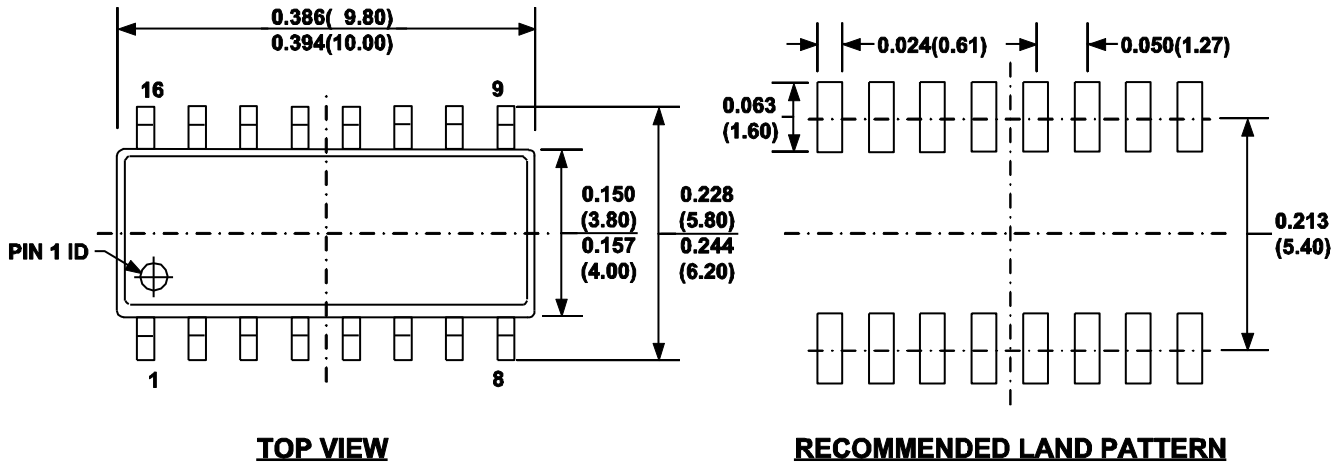

NOTE:

- 1) CONTROL DIMENSION IS IN INCHES. DIMENSION IN BRACKET IS IN MILLIMETERS.
- 2) PACKAGE LENGTH DOES NOT INCLUDE MOLD FLASH, PROTRUSIONS OR GATE BURRS.
- 3) PACKAGE WIDTH DOES NOT INCLUDE INTERLEAD FLASH OR PROTRUSIONS.
- 4) LEAD COPLANARITY (BOTTOM OF LEADS AFTER FORMING) SHALL BE 0.004" INCHES MAX.
- 5) DRAWING CONFORMS TO JEDEC MS-012, VARIATION AC.
- 6) DRAWING IS NOT TO SCALE.

NOTICE: The information in this document is subject to change without notice. Please contact MPS for current specifications. Users should warrant and guarantee that third party Intellectual Property rights are not infringed upon when integrating MPS products into any application. MPS will not assume any legal responsibility for any said applications.