

SN54LVT162244, SN74LVT162244 3.3-V ABT 16-BIT BUFFERS/DRIVERS WITH 3-STATE OUTPUTS

JUNE 1993

- Output Ports Have Equivalent 22- Ω Series Resistors, So No External Resistors Are Required
- State-of-the-Art Advanced BICMOS Technology (ABT) Design for 3.3-V Operation and Low-Static Power Dissipation
- Member of the Texas Instruments *Widebus*[™] Family
- Supports Mixed-Mode Signal Operation (5-V Input and Output Voltages With 3.3-V V_{CC})
- Supports Unregulated Battery Operation Down to 2.7 V
- Typical V_{OLP} (Output Ground Bounce) < 0.8 V at $V_{CC} = 3.3$ V, $T_A = 25^\circ\text{C}$
- ESD Protection Exceeds 2000 V Per MIL-STD-883C, Method 3015; Exceeds 200 V Using Machine Model ($C = 200$ pF, $R = 0$)
- Latch-Up Performance Exceeds 500 mA Per JEDEC Standard JESD-17
- Bus-Hold Data Inputs Eliminate the Need for External Pullup Resistors
- Distributed V_{CC} and GND Pin Configuration Minimizes High-Speed Switching Noise
- Flow-Through Architecture Optimizes PCB Layout
- Packaged in Plastic 300-mil Shrink Small-Outline and Thin Shrink Small-Outline Packages and 380-mil Fine-Pitch Ceramic Flat Packages Using 25-mil Center-to-Center Spacings

SN54LVT162244 . . . WD PACKAGE
SN74LVT162244 . . . DGG OR DL PACKAGE
(TOP VIEW)

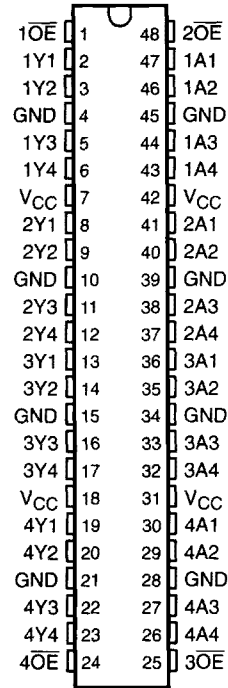

PRODUCT PREVIEW

description

The 'LVT162244 is a 16-bit buffer and line driver designed for low-voltage (3.3-V) V_{CC} operation, but with the capability to provide a TTL interface to a 5-V system environment. The device can be used as four 4-bit buffers, two 8-bit buffers, or one 16-bit buffer. This device provides true outputs and symmetrical \overline{OE} (active-low output-enable) inputs.

The outputs, which are designed to source or sink up to 12 mA, include 22- Ω series resistors to reduce overshoot and undershoot.

Active bus-hold circuitry is provided to hold unused or floating data inputs at a valid logic level.

The SN74LVT162244 is available in TI's shrink small-outline (DL) and thin shrink small-outline (DGG) packages, which provide twice the I/O pin count and functionality of standard small-outline packages in the same printed-circuit-board area.

The SN54LVT162244 is characterized for operation over the full military temperature range of -55°C to 125°C .

The SN74LVT162244 is characterized for operation from -40°C to 85°C .

Widebus is a trademark of Texas Instruments Incorporated.

PRODUCT PREVIEW information concerns products in the formative or design phase of development. Characteristic data and other specifications are design goals. Texas Instruments reserves the right to change or discontinue these products without notice.



Copyright © 1993, Texas Instruments Incorporated

SN54LVT162244, SN74LVT162244
3.3-V ABT 16-BIT BUFFERS/DRIVERS
WITH 3-STATE OUTPUTS

JUNE 1993

logic diagram (positive logic)

FUNCTION TABLE
(each buffer)

INPUTS		OUTPUT
OE	A	Y
L	H	H
L	L	L
H	X	Z

logic symbol†

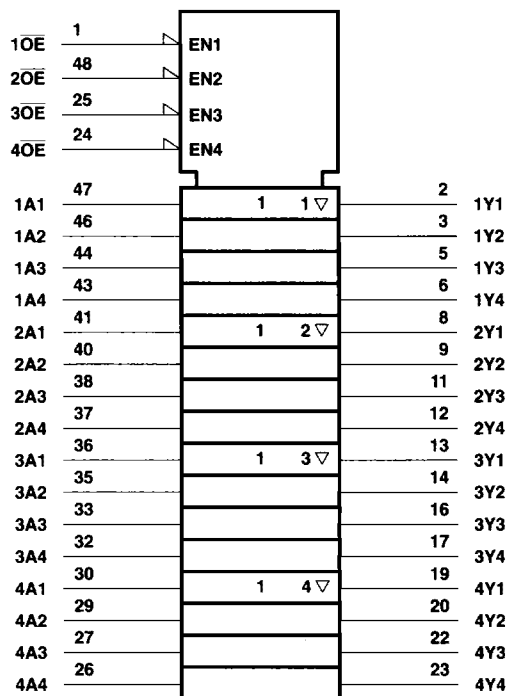

† This symbol is in accordance with ANSI/IEEE Std 91-1984 and IEC Publication 617-12.

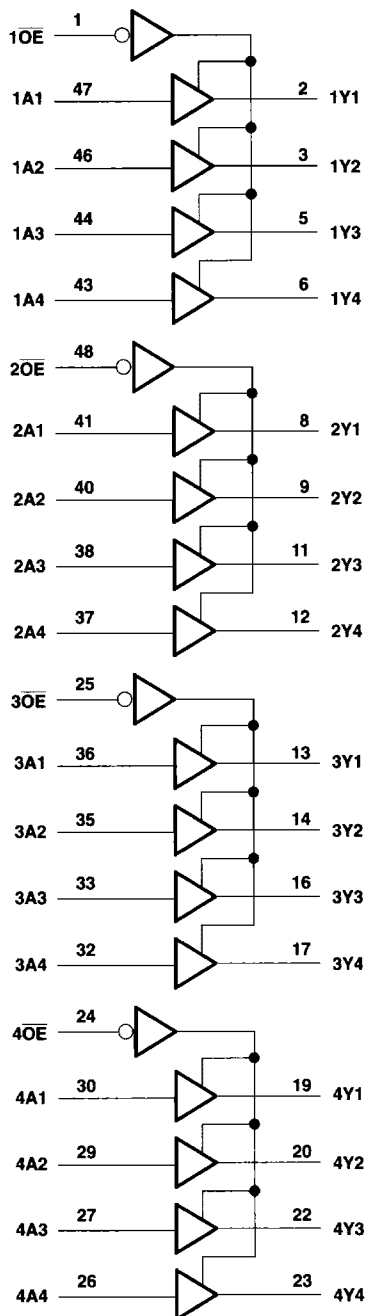

PRODUCT PREVIEW

SN54LVT162244, SN74LVT162244
3.3-V ABT 16-BIT BUFFERS/DRIVERS
WITH 3-STATE OUTPUTS

JUNE 1993

absolute maximum ratings over operating free-air temperature range (unless otherwise noted)†

Supply voltage range, V_{CC}	-0.5 V to 4.6 V
Input voltage range, V_I (see Note 1)	-0.5 V to 7 V
Voltage range applied to any output in the high state or power-off state, V_O (see Note 1)	-0.5 V to 7 V
Current into any output in the low state, I_O	30 mA
Current into any output in the high state, I_O (see Note 2)	30 mA
Input clamp current, I_{IK} ($V_I < 0$)	-50 mA
Output clamp current, I_{OK} ($V_O < 0$)	-50 mA
Maximum power dissipation at $T_A = 55^\circ\text{C}$ (in still air): DGG package	0.8 W
DL package	0.85 W
Storage temperature range	-65°C to 150°C

† Stresses beyond those listed under "absolute maximum ratings" may cause permanent damage to the device. These are stress ratings only, and functional operation of the device at these or any other conditions beyond those indicated under "recommended operating conditions" is not implied. Exposure to absolute-maximum-rated conditions for extended periods may affect device reliability.

- NOTES: 1. The input and output negative-voltage ratings may be exceeded if the input and output clamp-current ratings are observed.
 2. This current will only flow when the output is in the high state and $V_O > V_{CC}$.

recommended operating conditions

		SN54LVT162244		SN74LVT162244		UNIT
		MIN	MAX	MIN	MAX	
V_{CC}	Supply voltage	2.7	3.6	2.7	3.6	V
V_{IH}	High-level input voltage	2		2		V
V_{IL}	Low-level input voltage		0.8		0.8	V
V_I	Input voltage		5.5		5.5	V
I_{OH}	High-level output current		-12		-12	mA
I_{OL}	Low-level output current		12		12	mA
$\Delta t/\Delta v$	Input transition rise or fall rate	Outputs enabled		10	10	ns/V
T_A	Operating free-air temperature	-55	125	-40	85	°C

PRODUCT PREVIEW

SN54LVT162244, SN74LVT162244
3.3-V ABT 16-BIT BUFFERS/DRIVERS
WITH 3-STATE OUTPUTS

JUNE 1993

electrical characteristics over recommended operating free-air temperature range (unless otherwise noted)

PARAMETER	TEST CONDITIONS		SN54LVT162244		SN74LVT162244		UNIT
			MIN	MAX	MIN	MAX	
V_{IK}	$V_{CC} = 2.7\text{ V}$,	$I_I = -18\text{ mA}$		-1.2		-1.2	V
V_{OH}	$V_{CC} = 3\text{ V}$,	$I_{OH} = -12\text{ mA}$	2		2		V
V_{OL}	$V_{CC} = 3\text{ V}$,	$I_{OL} = 12\text{ mA}$		0.8		0.8	V
I_I	$V_{CC} = 0\text{ or MAX}^\dagger$, $V_I = 5.5\text{ V}$			10		10	μA
	$V_{CC} = 3.6\text{ V}$,	$V_I = V_{CC}\text{ or GND}$	Control pins	± 1		± 1	
	$V_{CC} = 3.6\text{ V}$,	$V_I = V_{CC}$	Data pins	1		1	
	$V_{CC} = 3.6\text{ V}$,	$V_I = 0$		-5		-5	
I_{off}	$V_{CC} = 0$,	$V_I\text{ or }V_O = 0\text{ to }4.5\text{ V}$				± 100	μA
$I_I(\text{hold})$	$V_{CC} = 3\text{ V}$	$V_I = 0.8\text{ V}$	A inputs	75		75	μA
		$V_I = 2\text{ V}$		-75		-75	
I_{OZH}	$V_{CC} = 3.6\text{ V}$,	$V_O = 3\text{ V}$		5		5	μA
I_{OZL}	$V_{CC} = 3.6\text{ V}$,	$V_O = 0.5\text{ V}$		-5		-5	μA
I_{CC}	$V_{CC} = 3.6\text{ V}$, $V_I = V_{CC}\text{ or GND}$	$I_O = 0$,	Outputs high	0.19		0.1	mA
			Outputs low	5		5	
			Outputs disabled	0.19		0.1	
ΔI_{CC}^\S	$V_{CC} = 3\text{ V to }3.6\text{ V}$, One input at $V_{CC} - 0.6\text{ V}$, Other inputs at $V_{CC}\text{ or GND}$			0.2		0.2	mA
C_i	$V_I = 3\text{ V or }0$						pF
C_o	$V_O = 3\text{ V or }0$						pF

† All typical values are at $V_{CC} = 3.3\text{ V}$, $T_A = 25^\circ\text{C}$.

‡ For conditions shown as MIN or MAX, use the appropriate value specified under recommended operating conditions.

§ This is the increase in supply current for each input that is at the specified TTL voltage level rather than V_{CC} or GND.

PRODUCT PREVIEW

