

RF & MICROWAVE TRANSISTORS L-BAND RADAR APPLICATIONS

- REFRACTORY/GOLD METALLIZATION
- EMITTER SITE BALLASTED
- 5:1 VSWR CAPABILITY
- LOW THERMAL RESISTANCE
- INPUT/OUTPUT MATCHING
- OVERLAY GEOMETRY
- METAL/CERAMIC HERMETIC PACKAGE
- P_{OUT} = 5.5 W MIN. WITH 10 dB GAIN

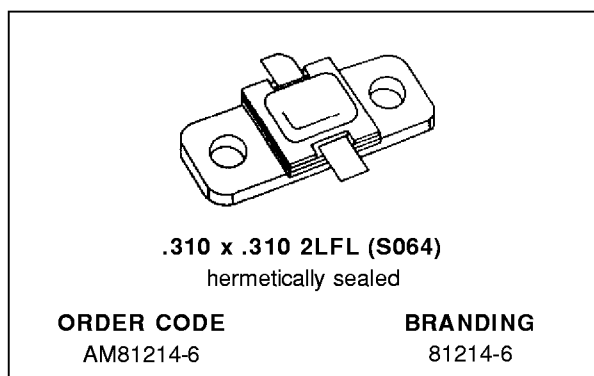

DESCRIPTION

The AM81214-006 device is a high power Class C transistor specifically designed for L-Band Radar pulsed driver applications.

This device is capable of operation over a wide range of pulse widths, duty cycles, and temperatures and is capable of withstanding 5:1 output VSWR at rated RF conditions. Low RF thermal resistance and computerized automatic wire bonding techniques ensure high reliability and product consistency.

AM81214-006 is supplied in the grounded IM-PAC™ Hermetic Metal/Ceramic package with internal input/output matching structures.

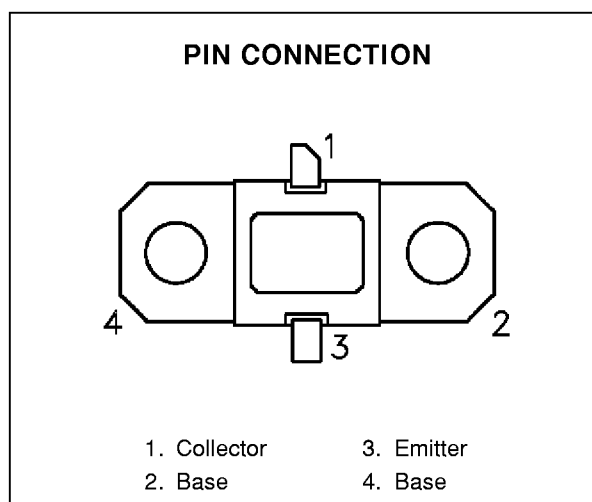

ABSOLUTE MAXIMUM RATINGS (T_{case} = 25°C)

Symbol	Parameter	Value	Unit
P _{DISS}	Power Dissipation* (T _C ≤ 100°C)	16.7	W
I _C	Device Current*	0.82	A
V _{CC}	Collector-Supply Voltage*	32	V
T _J	Junction Temperature (Pulsed RF Operation)	250	°C
T _{STG}	Storage Temperature	- 65 to +200	°C

THERMAL DATA

R _{TH(j-c)}	Junction-Case Thermal Resistance*	9.0	°C/W
----------------------	-----------------------------------	-----	------

*Applies only to rated RF amplifier operation

ELECTRICAL SPECIFICATIONS ($T_{case} = 25^{\circ}C$)

STATIC

Symbol	Test Conditions		Value			Unit
			Min.	Typ.	Max.	
BV_{CBO}	$I_C = 1\text{ mA}$	$I_E = 0\text{ mA}$	48	—	—	V
BV_{CER}	$I_C = 5\text{ mA}$	$R_{BE} = 10\Omega$	48	—	—	V
BV_{EBO}	$I_E = 1\text{ mA}$	$I_C = 0\text{ mA}$	3.5	—	—	V
I_{CES}	$V_{BE} = 0\text{ V}$	$V_{CE} = 28\text{ V}$	—	—	500	μA
h_{FE}	$V_{CE} = 5\text{ V}$	$I_C = 500\text{ mA}$	15	—	300	—

DYNAMIC

Symbol	Test Conditions			Value			Unit
				Min.	Typ.	Max.	
P_{OUT}	$f = 1.2 - 1.4\text{ GHz}$	$P_{IN} = 0.5\text{ W}$	$V_{CC} = 28\text{ V}$	—	5.5	6.2	W
η_C	$f = 1.2 - 1.4\text{ GHz}$	$P_{IN} = 0.5\text{ W}$	$V_{CC} = 28\text{ V}$	47	52	—	%
G_P	$f = 1.2 - 1.4\text{ GHz}$	$P_{IN} = 0.5\text{ W}$	$V_{CC} = 28\text{ V}$	10	10.5	—	dB

Note: Pulse Width = 1000 μ S
 Duty Cycle = 10%

TYPICAL PERFORMANCE

TYPICAL BROADBAND PERFORMANCE

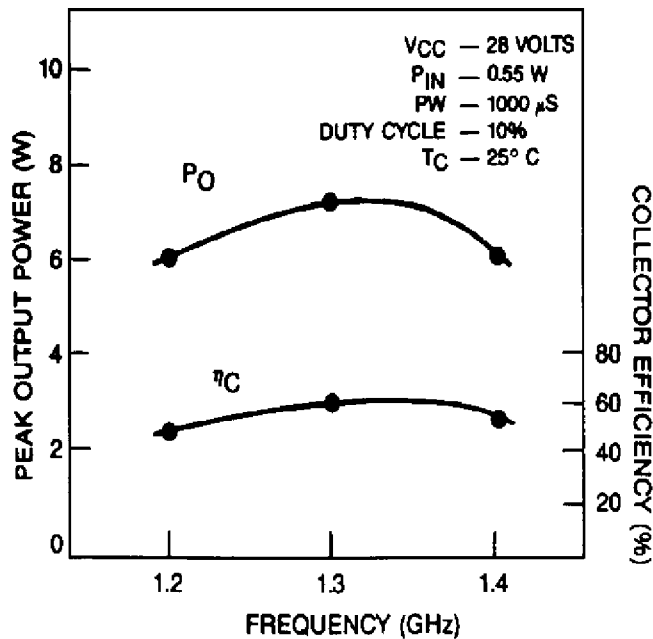

IMPEDANCE DATA

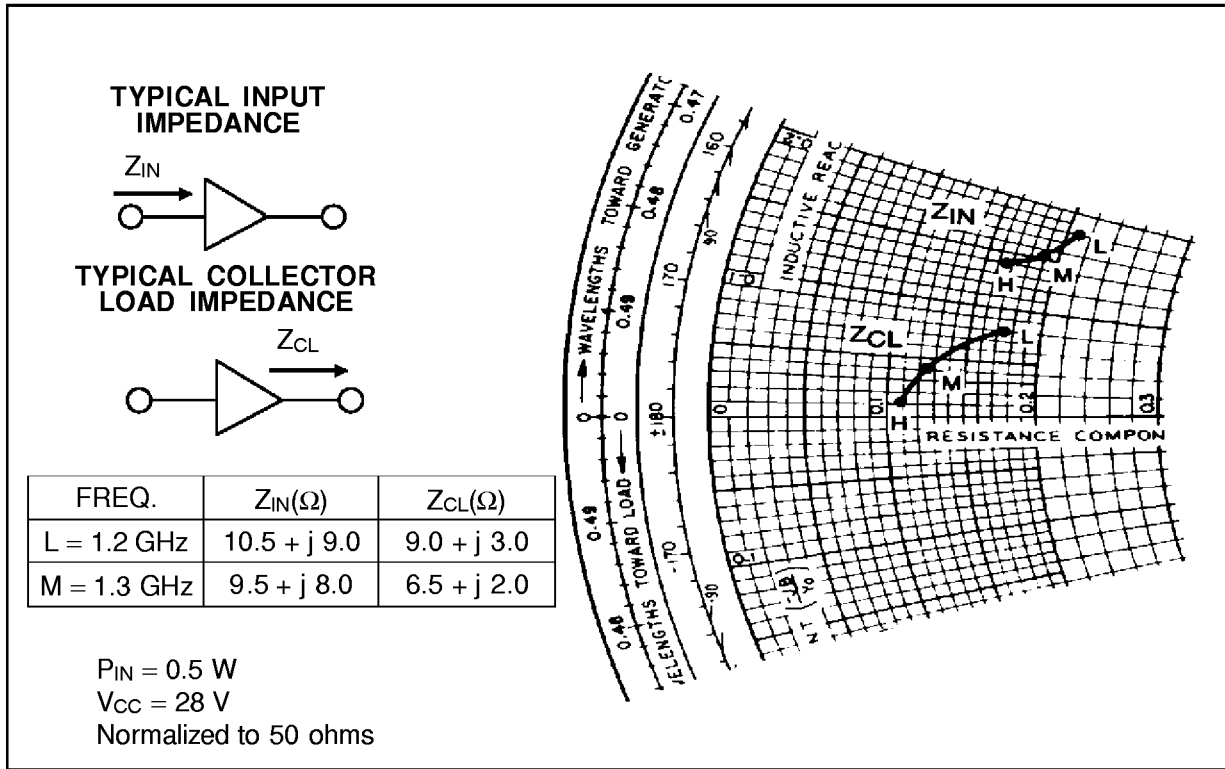

TEST CIRCUIT

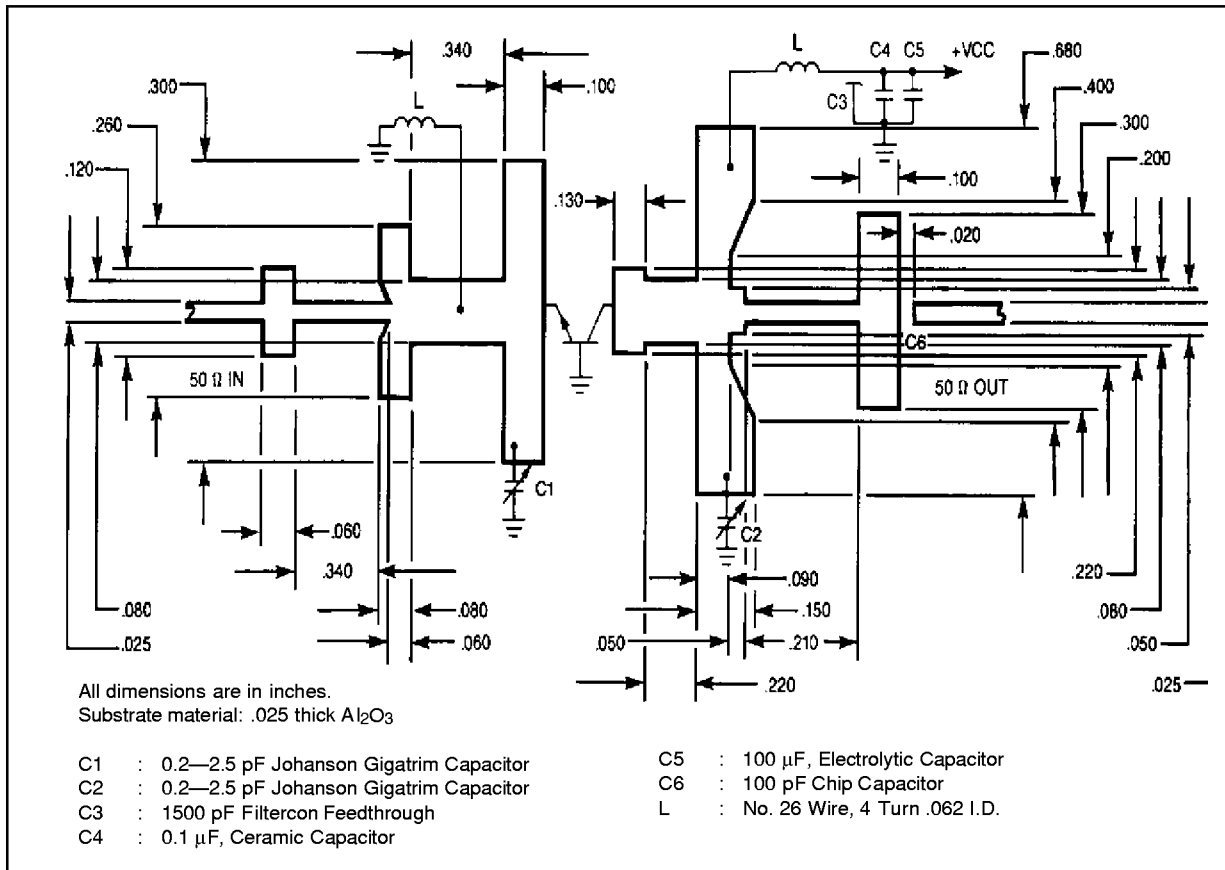

PACKAGE MECHANICAL DATA

Ref.: Dwg. No. 12-0221 rev. A

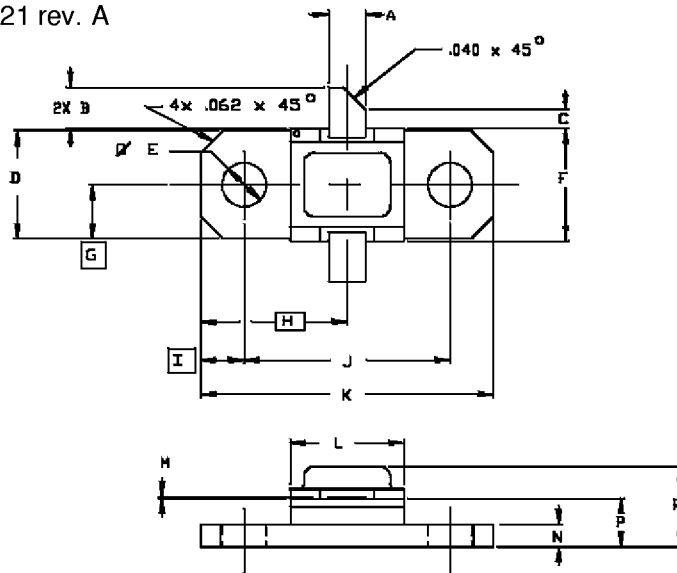

SGS-THOMSON MICROELECTRONICS			CONT'D		
	MINIMUM Inches/mm	MAXIMUM Inches/mm		MINIMUM Inches/mm	MAXIMUM Inches/mm
A	.095/2,41	.105/2,67	K	.790/20,07	.810/20,57
B	.100/2,54	.120/3,05	L	.300/7,62	.320/8,13
C	.050/1,27		M	.003/0,08	.006/0,15
D	.286/7,26	.306/7,77	N	.052/1,32	.072/1,83
E	.110/2,79	.130/3,30	P	.118/3,00	.131/3,33
F	.306/7,77	.318/8,08	R		.230/5,84
G	.148/3,76				
H	.400/10,16				
I	.119/3,02				
J	.552/14,02	.572/14,53			

Information furnished is believed to be accurate and reliable. However, SGS-THOMSON Microelectronics assumes no responsibility for the consequences of use of such information nor for any infringement of patents or other rights of third parties which may result from its use. No license is granted by implication or otherwise under any patent or patent rights of SGS-THOMSON Microelectronics. Specifications mentioned in this publication are subject to change without notice. This publication supersedes and replaces all information previously supplied. SGS-THOMSON Microelectronics products are not authorized for use as critical components in life support devices or systems without express written approval of SGS-THOMSON Microelectronics.

©1995 SGS-THOMSON Microelectronics - All Rights Reserved

SGS-THOMSON Microelectronics GROUP OF COMPANIES

Australia - Brazil - France - Germany - Hong Kong - Italy - Japan - Korea - Malaysia - Malta - Morocco - The Netherlands - Singapore - Spain - Sweden - Switzerland - Taiwan - Thailand - United Kingdom - U.S.A.