

Quad high-performance operational amplifier

NE/SE5514

DESCRIPTION

The NE/SE5514 family of quad operational amplifiers sets new standards in bipolar quad amplifier performance. The amplifiers feature low input bias current and low offset voltages. Pinout is identical to LM324/LM348 which facilitates direct product substitution for improved system performance in dual supply applications. Output characteristics are similar to a $\mu A741$ with improved slew and drive capability.

FEATURES

- Low input bias current: $< \pm 3nA$
- Low input offset current: $< \pm 3nA$
- Low input offset voltage: $< 1mV$
- Low supply current: $1.5mA/A$
- $1V/\mu s$ slew rate
- High input impedance: $100M\Omega$
- High common-mode impedance: $10G\Omega$
- Internal compensation for unity gain
- 600Ω drive capability ($7V_{RMS}$)

APPLICATIONS

- AC amplifiers
- RC active filters
- Transducer amplifiers
- DC gain block
- Instrumentation amplifier

PIN CONFIGURATIONS

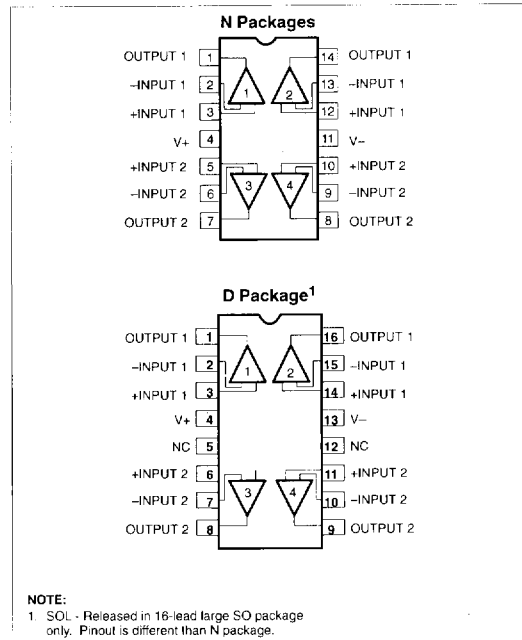

ORDERING INFORMATION

DESCRIPTION	TEMPERATURE RANGE	ORDER CODE	DWG #
16-Pin Plastic Small Outline Large (SOL) package	0 to +70°C	NE5514D	0171B
14-Pin Plastic Dual In-Line Package (DIP)	0 to +70°C	NE5514N	0405B
14-Pin Plastic Dual In-Line Package (DIP)	-55 to +125°C	SE5514N	0405B

Quad high-performance operational amplifier

NE/SE5514

EQUIVALENT SCHEMATIC

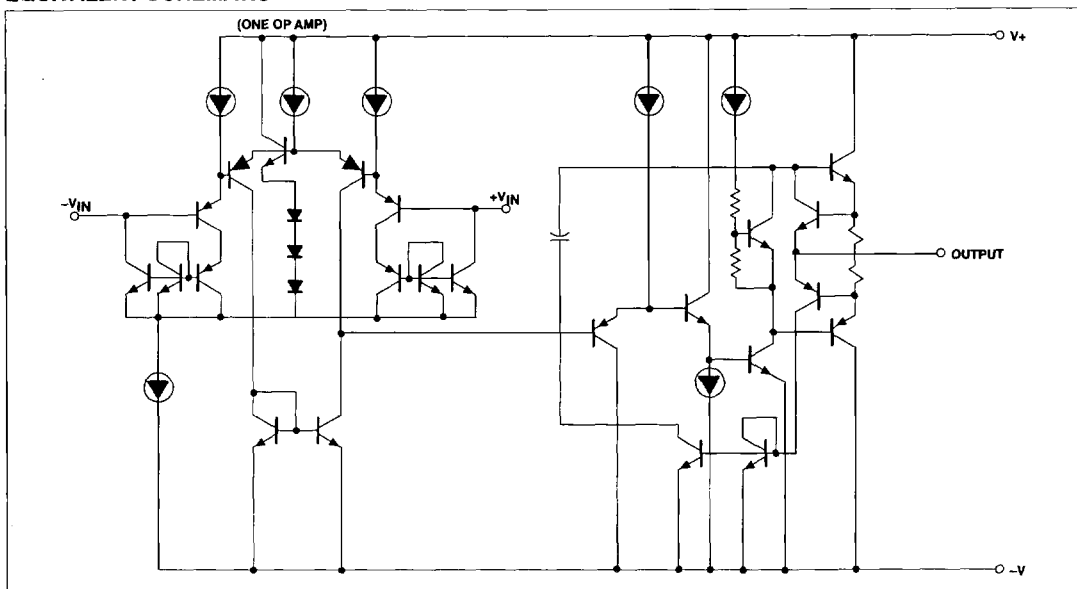

ABSOLUTE MAXIMUM RATINGS

SYMBOL	PARAMETER	RATING	UNIT
V _{CC}	Supply voltage	±16	V
V _{DIFF}	Differential input voltage	32	V
V _{IN}	Input voltage	0 to 32	V
	Output short to ground	Continuous	
T _{STG}	Storage temperature range	-65 to +150	°C
T _{SOLD}	Lead soldering temperature (10sec max)	300	°C
T _A	Operating ambient temperature range		
	NE5514	0 to 70	°C
	SE5514	-55 to +125	°C
P _{MAX}	Maximum power dissipation		
	T _A =25°C (still-air) ¹		
	N package	1420	mW
	D package	1250	mW

NOTES:

- The following derating factors should be applied above 25°C
 - N package at 11.4mW/°C
 - D package at 10.0mW/°C

Quad high-performance operational amplifier

NE/SE5514

ELECTRICAL CHARACTERISTICS $V_{CC} = \pm 15V$, $T_A = 25^\circ C$ unless otherwise specified.

SYMBOL	PARAMETER	TEST CONDITIONS	SE5514			NE5514			UNIT
			Min	Typ	Max	Min	Typ	Max	
V_{OS}	Input offset voltage	$R_S=100\Omega$, $T_A=+25^\circ C$ Over temp.		0.7 1	2 3		1 1.5	5 6	mV
ΔV_{OS}		Over temp.		4			5		$\mu V/^\circ C$
I_{OS}	Input offset current	$R_S=100k\Omega$, $T_A=+25^\circ C$ Over temp.		3 4	10 20		6 8	20 30	nA
ΔI_{OS}		Over temp.		30			40		$pA/^\circ C$
I_{BIAS}	Input bias current	$R_S=100k\Omega$, $T_A=+25^\circ C$ Over temp.		3 4	10 20		6 8	20 30	nA
ΔI_{BIAS}		Over temp.		30			40		$pA/^\circ C$
R_{IN}	Input resistance differential	$T_A=25^\circ C$		100			100		M Ω
V_{CM}	Input common mode range	$T_A=25^\circ C$ Over temp.	± 13.5 ± 13	± 13.7 ± 13.2		± 13.5 ± 13	± 13.7 ± 13.2		V
CMRR	Input common-mode rejection ratio	$V_{CC}=\pm 15V$, $V_{IN}=\pm 13.5V$ @ $T_A=25^\circ C$ $V_{IN}=\pm 13V$ @ Over temp.	70	100		70	100		dB
A_V	Large-signal voltage gain	$R_L=2k\Omega$, $T_A=25^\circ C$ $V_O = \pm 10V$, Over temp.	50 25	200		50 25	200		V/mV
SR	Slew rate	$T_A=25^\circ C$	0.6	1		0.6	1		V/ μs
GBW	Small-signal unity gain bandwidth	$T_A=25^\circ C$		3			3		MHz
θ_M	Phase margin	$T_A=25^\circ C$		45			45		Deg
V_{OUT}	Output voltage swing	$R_L=2k\Omega$, $T_A=25^\circ C$ Over temp.	± 13 ± 12.5	± 13.5 ± 13		± 13 ± 12.5	± 13.5 ± 13		V
V_{OUT}	Output voltage swing	$R_L=600\Omega^1$, $T_A=25^\circ C$ Over temp.	± 10 ± 7.5	± 11.5 ± 9		± 10 ± 8	± 11.5 ± 9		V
I_{CC}	Power supply current	$R_L=Open$, $T_A=25^\circ C$ Over temp.		6 7	10 12		6 7	10 12	mA
PSRR	Power supply rejection ratio	$\pm 5V \leq V_{CC} \leq \pm 15V$ Over temp.	80	110		80	110		dB
AA	Amplifier to amplifier coupling	$f=1kHz$ to $20kHz$, $T_A=25^\circ C$		-120			-120		dB
THD	Total harmonic distortion	$f=10kHz$, $T_A=25^\circ C$ $V_O=7V_{RMS}$		0.01			0.01		%
V_{NOISE}	Input noise voltage	$f=1kHz$, $T_A=25^\circ C$		30			30		nV/ \sqrt{Hz}
I_{SC}	Short-circuit current	$T_A=25^\circ C$	10	40	60	10	40	60	mA

NOTES:

1. Not to exceed maximum power dissipation.