

## RF & MICROWAVE TRANSISTORS GENERAL PURPOSE AMPLIFIER APPLICATIONS

PRELIMINARY DATA

- REFRACTORY/GOLD METALLIZATION
- VSWR CAPABILITY 20:1 @ RATED CONDITIONS
- HERMETIC STRIPAC® PACKAGE
- P<sub>OUT</sub> = 7.0 W MIN. WITH 9.6 dB GAIN

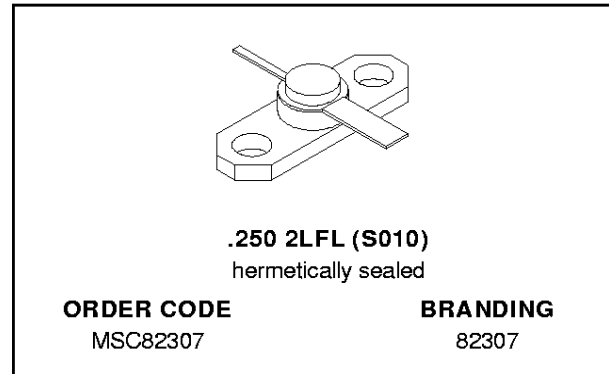

### DESCRIPTION

The MSC82307 is a common base hermetically sealed silicon NPN microwave power transistor utilizing a rugged overlay die geometry. This device is capable of withstanding 20:1 load VSWR at any phase angle under rated conditions.

The MSC82307 was designed for Class C amplifier/oscillator applications in the 1.5 - 2.3 GHz frequency range.

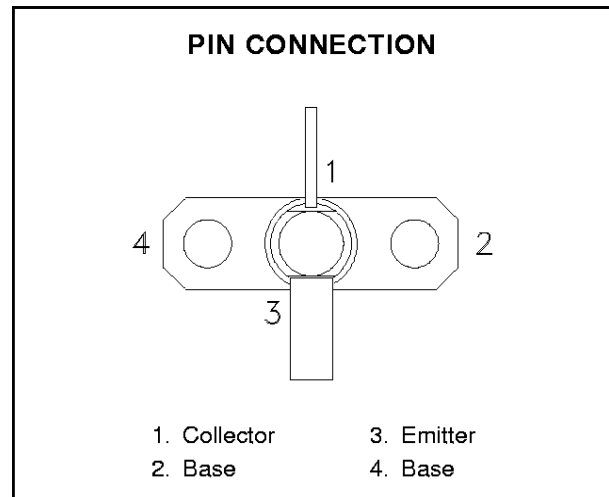

### ABSOLUTE MAXIMUM RATINGS (T<sub>case</sub> = 25°C)

Symbol	Parameter	Value	Unit
P <sub>DISS</sub>	Power Dissipation* (T <sub>C</sub> ≤ 50°C)	21.4	W
I <sub>C</sub>	Device Current*	1.2	A
V <sub>CC</sub>	Collector-Supply Voltage*	26	V
T <sub>J</sub>	Junction Temperature	200	°C
T <sub>STG</sub>	Storage Temperature	- 65 to +200	°C

### THERMAL DATA

R <sub>TH(j-c)</sub>	Junction-Case Thermal Resistance*	7.0	°C/W
----------------------	-----------------------------------	-----	------

\*Applies only to rated RF amplifier operation

# MSC82307

## ELECTRICAL SPECIFICATIONS (T<sub>case</sub> = 25°C)

### STATIC

Symbol	Test Conditions		Value			Unit
			Min.	Typ.	Max.	
BV <sub>CB0</sub>	I <sub>C</sub> = 1mA	I <sub>E</sub> = 0mA	44	—	—	V
BV <sub>EB0</sub>	I <sub>E</sub> = 1mA	I <sub>C</sub> = 0mA	3.5	—	—	V
BV <sub>CER</sub>	I <sub>C</sub> = 5mA	R <sub>BE</sub> = 10Ω	44	—	—	V
I <sub>CB0</sub>	V <sub>CB</sub> = 22V		—	—	0.5	mA
h <sub>FE</sub>	V <sub>CE</sub> = 5V	I <sub>C</sub> = 500mA	30	—	300	—

### DYNAMIC

Symbol	Test Conditions			Value			Unit
				Min.	Typ.	Max.	
P <sub>OUT</sub>	f = 2.3 GHz	P <sub>IN</sub> = 0.76 W	V <sub>CC</sub> = 22 V	7.0	8.0	—	W
η <sub>c</sub>	f = 2.3 GHz	P <sub>IN</sub> = 0.76 W	V <sub>CC</sub> = 22 V	40	45	—	%
G <sub>P</sub>	f = 2.3 GHz	P <sub>IN</sub> = 0.76 W	V <sub>CC</sub> = 22 V	9.6	10.2	—	dB
C <sub>OB</sub>	f = 1 MHz	V <sub>CB</sub> = 22 V		—	—	8.5	pF

### TEST CIRCUIT

Ref.: Dwg. No. C125518

All dimensions are in inches.

Frequency 2.3 GHz

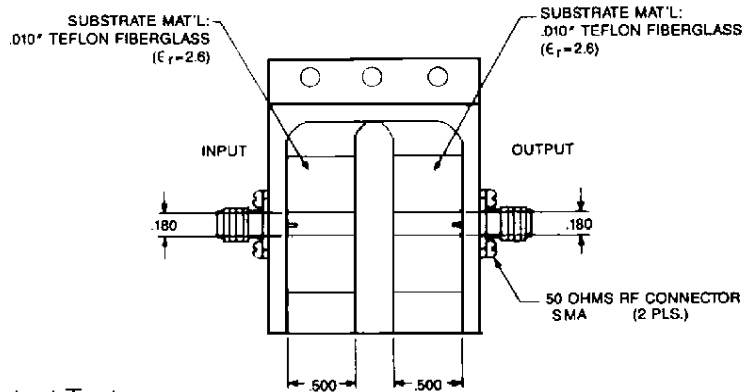

RF Amplifier Power Output Test

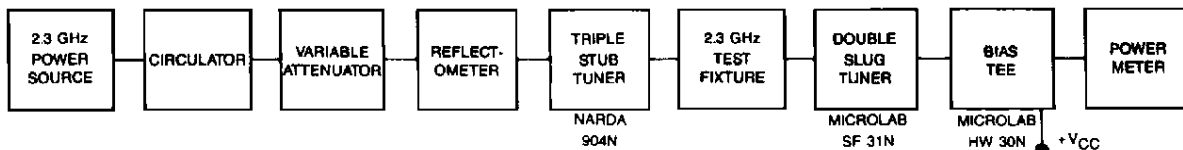

PACKAGE MECHANICAL DATA

Ref.: Dwg. No.: J135021C

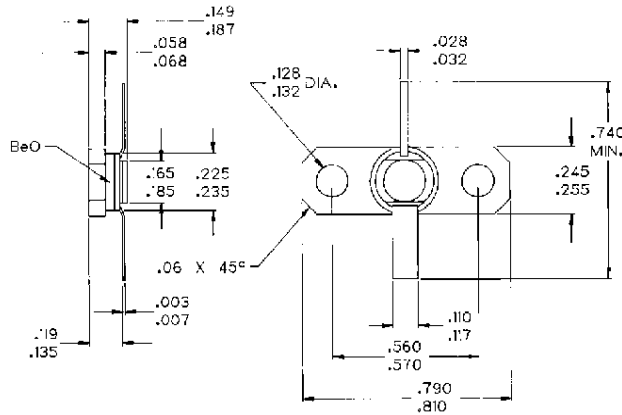

NOTES:  
 1. ALL TOLERANCE ± .010 EXCEPT WHERE NOTED;  
 DIMENSIONS IN INCHES.

Information furnished is believed to be accurate and reliable. However, SGS-THOMSON Microelectronics assumes no responsibility for the consequences of use of such information nor for any infringement of patents or other rights of third parties which may result from its use. No license is granted by implication or otherwise under any patent or patent rights of SGS-THOMSON Microelectronics. Specifications mentioned in this publication are subject to change without notice. This publication supersedes and replaces all information previously supplied. SGS-THOMSON Microelectronics products are not authorized for use as critical components in life support devices or systems without express written approval of SGS-THOMSON Microelectronics.

© 1994 SGS-THOMSON Microelectronics - All Rights Reserved

SGS-THOMSON Microelectronics GROUP OF COMPANIES  
 Australia - Brazil - France - Germany - Hong Kong - Italy - Japan - Korea - Malaysia - Malta - Morocco - The Netherlands -  
 Singapore - Spain - Sweden - Switzerland - Taiwan - Thailand - United Kingdom - U.S.A