

550 mA LDO Linear Regulator

General Description

The FS8856 is a low-dropout linear regulator that operations in the input voltage range from +2.5V to +6.5V and delivers 550mA output current.

The high-accuracy output voltage is preset at an internally trimmed voltage 2.5V or 3.3V. Other output voltages can be mask-optioned from 1.5V to 5.0V with 100mV increment, except FS8856-29Cx which has 2.85V output voltage.

The FS8856 consist of a 1.25V reference compare amplifier, and a P-channel pass transistor. Other features include short-circuit protection and thermal shutdown protection. The FS8856 devices are available in TO-92 and SOT-89 packages.

Features

- **Low dropout voltage 750mV at 550mA (Typ.)**
- **Up to $\pm 35\text{mV}$ output voltage accuracy ($V_{\text{OUT}} \leq 3.5\text{V}$)**
Preset at 2.5V, 3.3V
Mask option from 1.5V to 5.0V
- **Small output capacitor**
- **Output current limit**
- **Thermal overload shutdown protection**
- **TO-92 and SOT-89 Packages**

Applications

- **CD-ROM Drivers**
- **DVD-ROM Drivers**
- **Portable Consumer Equipment**
- **Radio Control Systems**
- **Wireless Communication Systems**

Ordering Information

FS8856-xx x x

Package

Pin Out

E : TO-92	1.GND	2.IN	3.OUT
K : SOT-89	1.IN	2.GND	3.OUT
L : SOT-89	1.GND	2.IN	3.OUT
I : SOT-89	1.OUT	2.GND	3.IN
Y : SOT-89	1.GND	2.OUT	3.IN

Temperature Range

- C : Commercial Standard
- P : Commercial Standard, Lead(Pb) Free and Phosphorous(P) Free Package

Output Voltage

15 : 1.5V	27 : 2.7V	39 : 3.9V
16 : 1.6V	28 : 2.8V	40 : 4.0V
17 : 1.7V	29 : 2.85V	41 : 4.1V
18 : 1.8V	30 : 3.0V	42 : 4.2V
19 : 1.9V	31 : 3.1V	43 : 4.3V
20 : 2.0V	32 : 3.2V	44 : 4.4V
21 : 2.1V	33 : 3.3V	45 : 4.5V
22 : 2.2V	34 : 3.4V	46 : 4.6V
23 : 2.3V	35 : 3.5V	47 : 4.7V
24 : 2.4V	36 : 3.6V	48 : 4.8V
25 : 2.5V	37 : 3.7V	49 : 4.9V
26 : 2.6V	38 : 3.8V	50 : 5.0V

Note : **Mask option output types are available by order only.**

Pin Configurations

Part No.	Pin 1	Pin 2	Pin 3
FS8856-xxxE	GND	IN	OUT

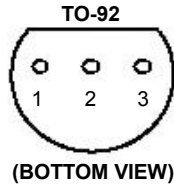

Part No.	Pin 1	Pin 2	Pin 3
FS8856-xxxK	IN	GND	OUT
FS8856-xxxL	GND	IN	OUT
FS8856-xxxI	OUT	GND	IN
FS8856-xxxY	GND	OUT	IN

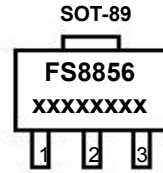

Package Marking Information

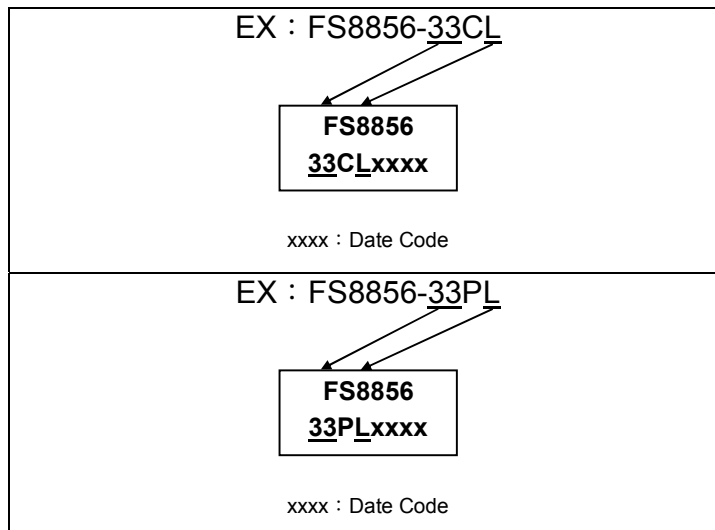

Pin Description

Part NO.	Symbol	Description
FS8856-xxxE FS8856-xxxK FS8856-xxxL FS8856-xxxI FS8856-xxxY	GND	Ground pin that provides the reference for all voltages.
	IN	Regulator input pin. Supply voltage can range from 2.5V to 6.5V. Bypass with a 1 μ F capacitor to GND.
	OUT	Regulator output pin. Sources up to 550mA. Bypass with a 3.3 μ F capacitor to GND.

Functional Block Diagram

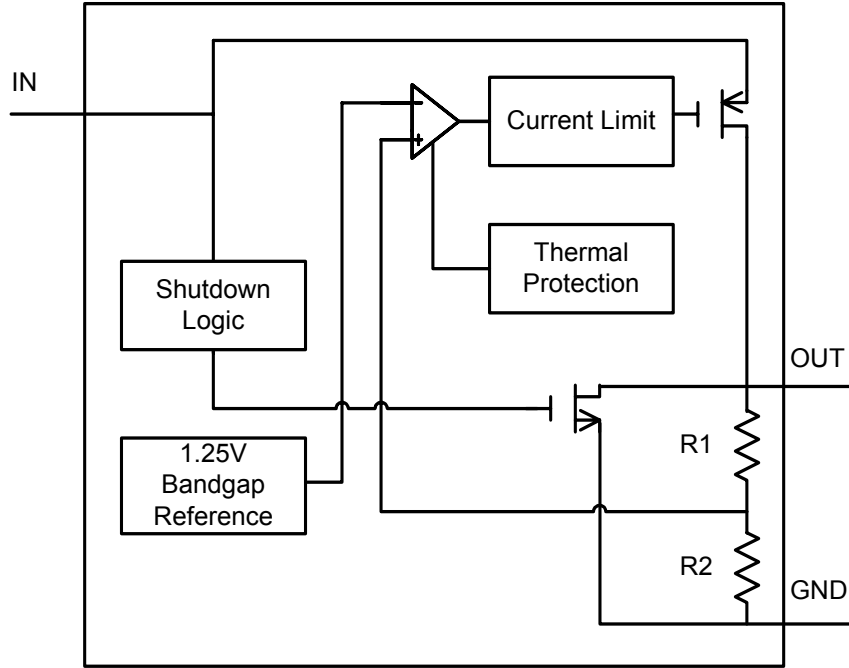

Typical Application Circuit

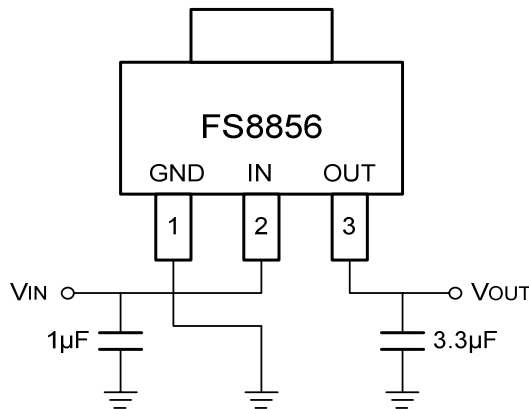

Absolute Maximum Ratings

Input voltage V_{IN} to GND	-----	7V
Output current limit, I_{LIMIT}	-----	0.8A
Continuous power dissipation, P_D		
SOT-89	-----	0.55W
TO-92	-----	0.55W

* The power dissipation values are based on the condition that junction temperature T_J and ambient temperature T_A difference is 100°C.

Junction Temperature, T_J ----- +155°C
 Storage temperature range, T_{STG} ----- -55°C to +150°C
 Operating junction temperature range ----- -40°C to +125°C
 Lead temperature (soldering, 10sec) ----- 260°C

* Stresses beyond those listed under “absolute maximum ratings” may cause permanent damage to the device. These are stress ratings only, and function operation of the device at these or any other conditions beyond those indicated under “recommended operating conditions” is not implied. Exposure to absolute-maximum-rated conditions for extended periods may affect device reliability.

Electrical Characteristics

($T_A=25^\circ\text{C}$, unless otherwise noted.)

Symbol	Parameter	Test Conditions	Min	Typ	Max	Unit
V_{IN}	Input Voltage		2.5		6.5	V
ΔV_{OUT}	Output Voltage Accuracy $1.5V \leq V_{OUT} \leq 3.5V$	$V_{IN} > V_{OUT} + 0.9V$, $V_{IN} \leq 6.5V$	-35		+35	mV
ΔV_{OUT}	Output Voltage Accuracy $3.5V < V_{OUT} \leq 5.0V$	$V_{IN} > V_{OUT} + 0.9V$, $V_{IN} \leq 6.5V$	-1.0		+1.0	%
I_{MAX}	Maximum Load Current		550			mA
I_{LIMIT}	Current Limit				0.8	A
I_{SC}	Short-Circuit Current	$V_{OUT}=0V$, $V_{IN} > V_{OUT} + 0.9V$		350	400	mA
I_Q	Ground Pin Current	$I_{LOAD}=0\text{mA}$ to 550mA , $V_{IN}=V_{OUT}+0.9V$		65	90	μA
V_{DROP}	Dropout Voltage	$I_{OUT}=100\text{mA}$		110	130	mV
		$I_{OUT}=300\text{mA}$		350	420	mV
		$I_{OUT}=500\text{mA}$		650	800	mV
		$I_{OUT}=550\text{mA}$		750	900	mV
ΔV_{LINE}	Line Regulation	$V_{OUT} + 0.9V < V_{IN} < 6.5V$, $I_{LOAD}=1\text{mA}$		0.2	0.3	%/V
ΔV_{LOAD}	Load Regulation	$I_{OUT}=0\text{mA}$ to 550mA		0.02	0.03	%/mA
$PSRR$	Ripple Rejection			70		dB
T_{SD}	Thermal Shutdown Temperature			155		$^\circ\text{C}$
T_{HYS}	Thermal Shutdown Hysteresis			10		$^\circ\text{C}$
θ_{JA}	Thermal Resistance	SOT-89			180	$^\circ\text{C/W}$
		TO-92			180	$^\circ\text{C/W}$

Typical Operating Characteristics

(C_{IN}=1.0μF, C_{OUT}=3.3μF, T_A=+25°C, unless otherwise noted.)

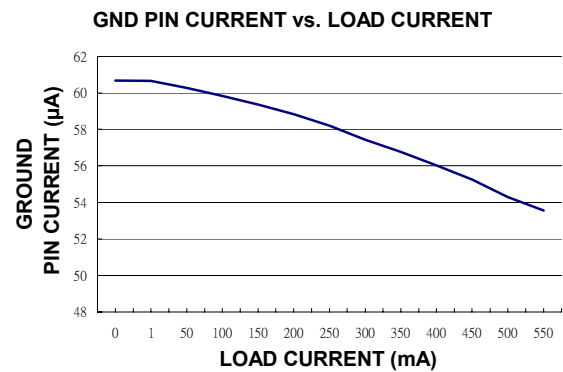
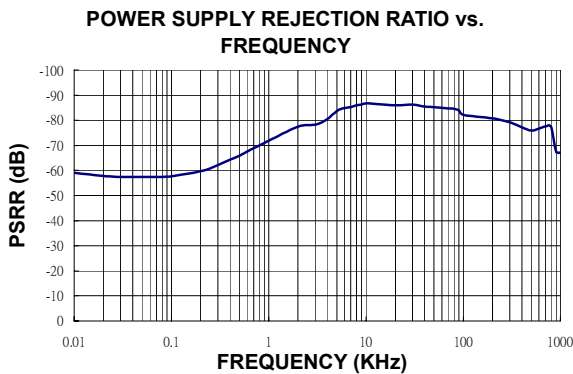
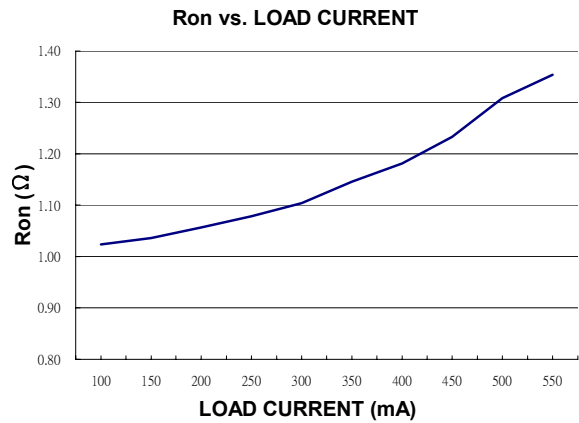
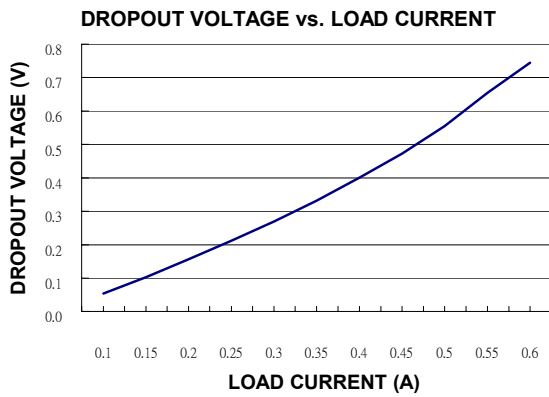
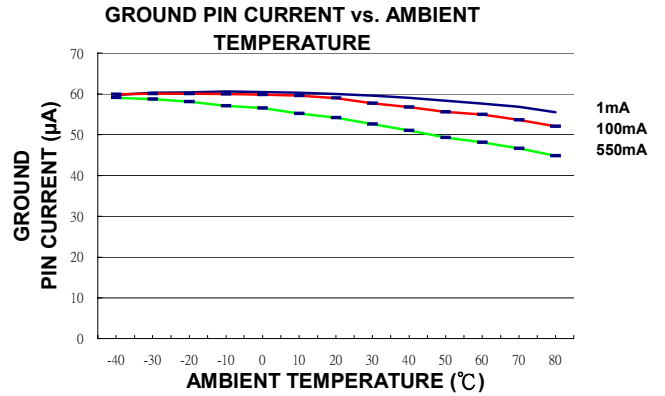
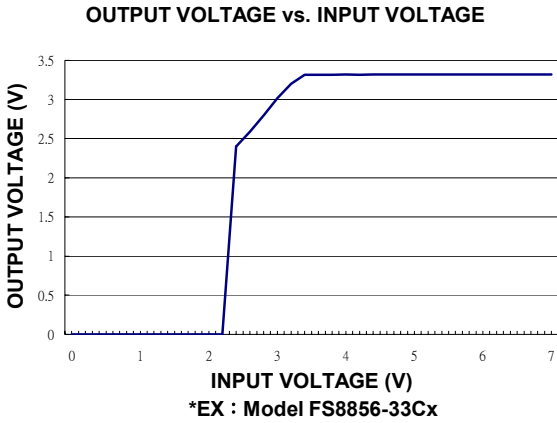

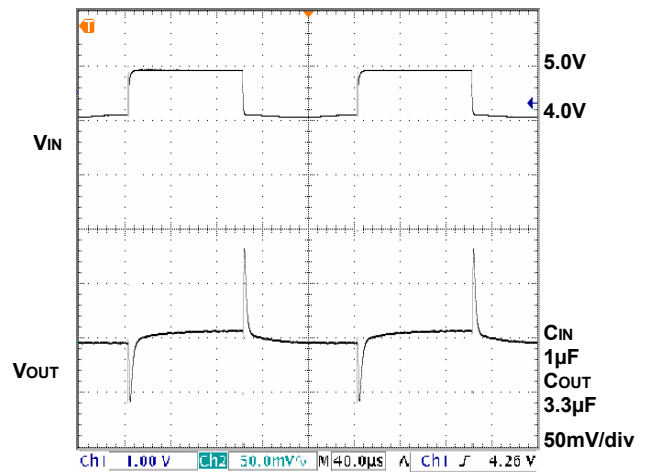
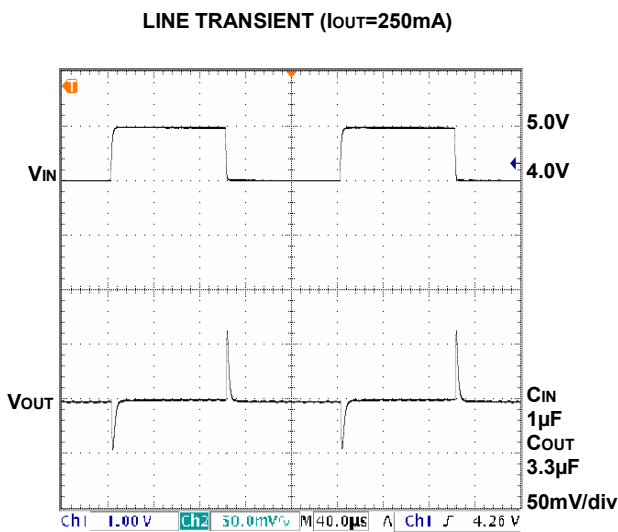
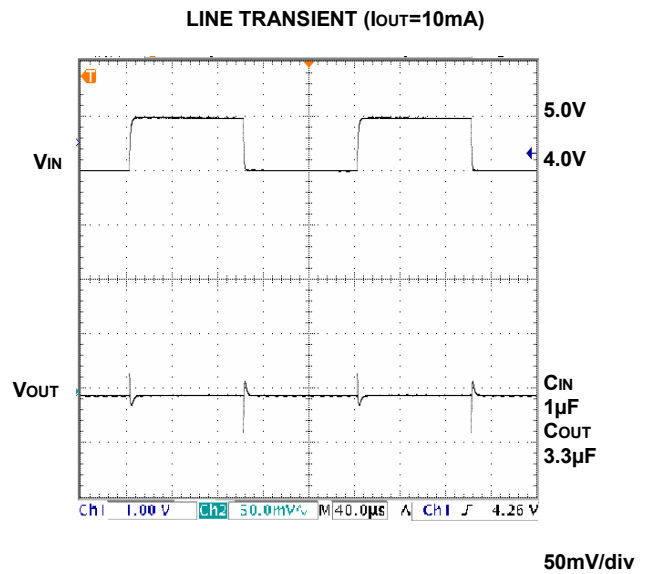
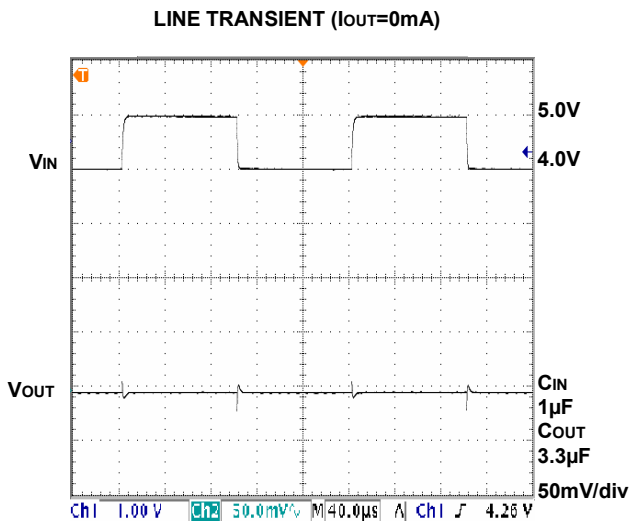
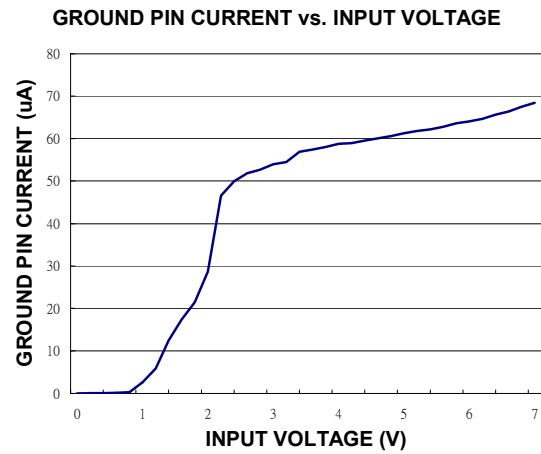
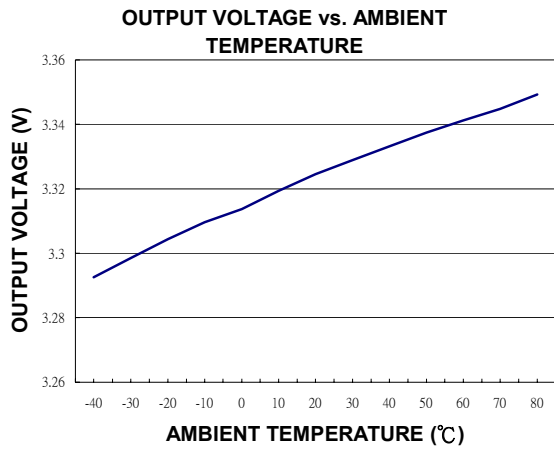

LINE TRANSIENT (I_{OUT}=550mA)

LOAD TRANSIENT

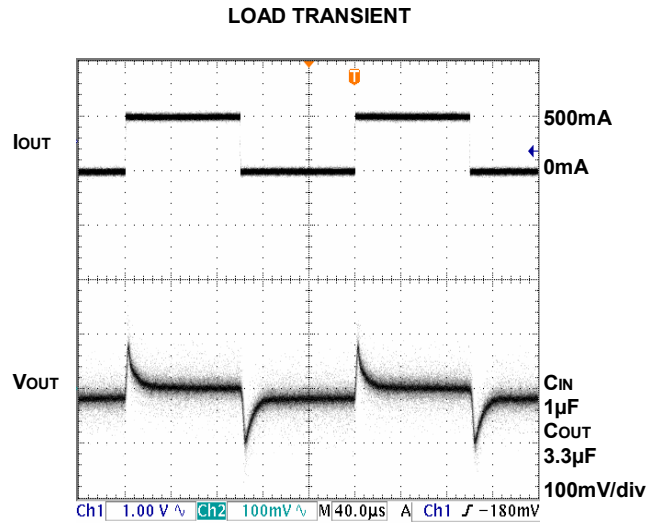
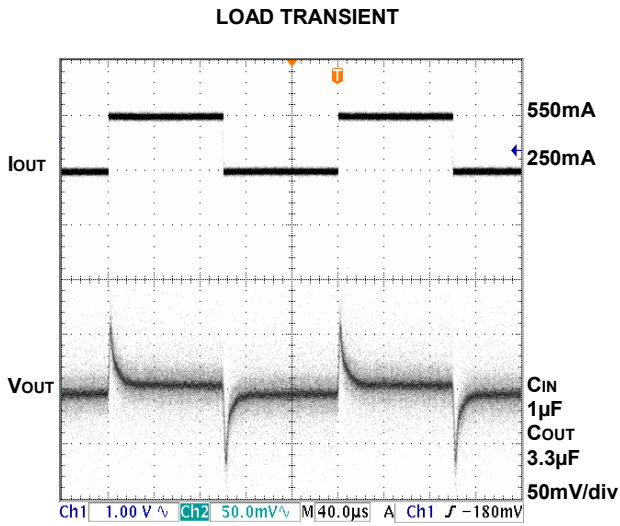
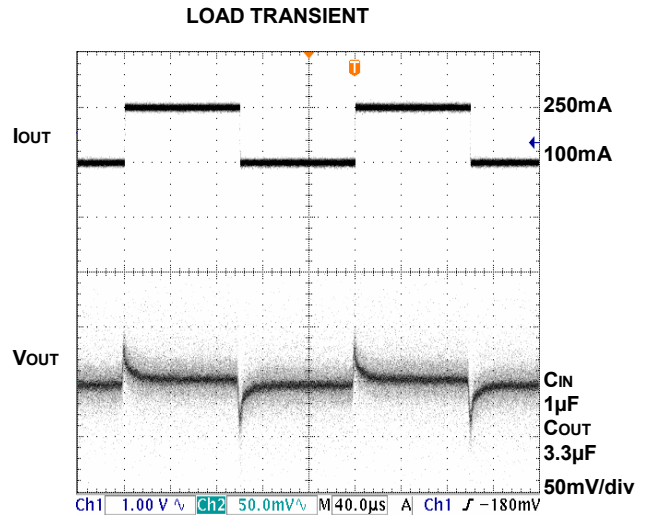
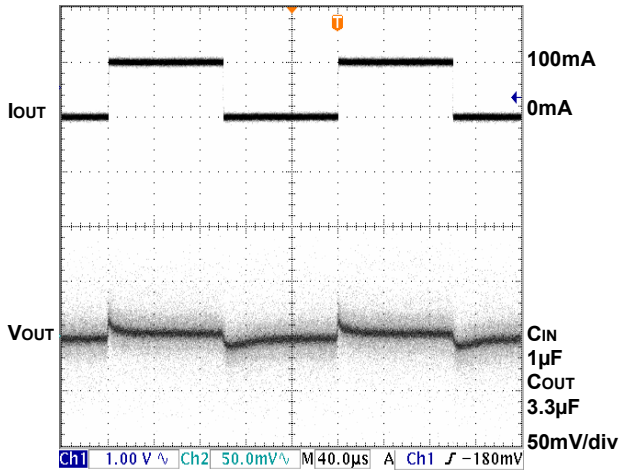

Detail Description

The FS8856 is a low-dropout linear regulator. The device provides preset 2.5V and 3.3V output voltages for output current up to 550mA. Other mask options for special output voltages from 1.5V to 5.0V with 100mV increment are also available. As illustrated in function block diagram, it consists of a 1.25V reference, error amplifier, P-channel pass transistor and an internal feedback voltage divider.

The 1.25V bandgap reference is connected to the error amplifier, which compares this reference with the feedback voltage and amplifies the voltage difference. If the feedback voltage is lower than the reference voltage, the pass-transistor gate is pulled lower, which allows more current to pass to the output pin and increases the output voltage. If the feedback voltage is too high, the pass-transistor gate is pulled up to decrease the output voltage.

The output voltage is feedback through an internal resistive divider connected to OUT pin. Additional blocks include an output current limiter, thermal sensor, and shutdown logic.

Internal P-channel Pass Transistor

The FS8856 features a P-channel MOSFET pass transistor. Unlike similar designs using PNP pass transistors, P-channel MOSFETs require no base drive, which reduces ground pin current. PNP-based regulators also waste considerable current in dropout when the pass transistor saturates, and use high base-drive currents under large loads. The FS8856 does not suffer from these problems and consumes only 65µA (Typ.) of ground pin current under heavy loads as well as in dropout conditions.

Output Voltage Selection

The FS8856 output voltage is preset at an internally trimmed voltage 2.5V, 3.3V or can be mask-optional from 1.5V to 5.0V with 100mV increment. The first two digits of part number suffix identify the output voltage (see [Ordering Information](#)). For example, the FS8856-33CL has a preset 3.3V output voltage.

Current Limit

The FS8856 also includes a fold back current limiter. It monitors and controls the pass transistor's gate voltage, estimates the output current, and limits the output current within 0.8A.

Thermal Overload Protection

Thermal overload protection limits total power dissipation in the FS8856. When the junction temperature exceeds $T_J = +155^\circ\text{C}$, a thermal sensor turns off the pass transistor, allowing the IC to cool down. The thermal sensor turns the pass transistor on again after the junction temperature cools down by 10°C , resulting in a pulsed output during continuous thermal overload conditions.

Thermal overload protection is designed to protect the FS8856 in the event of fault conditions. For continuous operation, the maximum operating junction temperature rating of $T_J = +125^\circ\text{C}$ should not be exceeded.

Operating Region and Power Dissipation

Maximum power dissipation of the FS8856 depends on the thermal resistance of the case and circuit board, the temperature difference between the die junction and ambient air, and the rate of airflow. The power dissipation across the devices is $P = I_{OUT} \times (V_{IN} - V_{OUT})$. The resulting maximum power dissipation is:

$$P_{MAX} = \frac{(T_J - T_A)}{\theta_{JC} + \theta_{CA}} = \frac{(T_J - T_A)}{\theta_{JA}}$$

Where $(T_J - T_A)$ is the temperature difference between the FS8856 die junction and the surrounding air, θ_{JC} is the thermal resistance of the package chosen, and θ_{CA} is the thermal resistance through the printed circuit board, copper traces and other materials to the surrounding air. For better heat-sinking, the copper area should be equally shared between the IN, OUT, and GND pins.

If the FS8856 uses a SOT-89 package and this package is mounted on a double sided printed circuit board with two square inches of copper allocated for "heat spreading", the resulting θ_{JA} is 180°C/W .

Based on a maximum operating junction temperature 125°C with an ambient of 25°C , the maximum power dissipation will be:

$$P_{MAX} = \frac{(T_J - T_A)}{\theta_{JC} + \theta_{CA}} = \frac{(125 - 25)}{180} = 0.555W$$

Thermal characteristics were measured using a double sided board with 1" x 2" square inches of copper area connected to the GND pin for "heat spreading".

Input-Output Voltage

A regulator's minimum input-output voltage differential,

or dropout voltage, determines the lowest usable supply voltage. In battery-powered systems, this will determine the useful end-of-life battery voltage. The FS8856 uses a P-channel MOSFET pass transistor, its dropout voltage is a function of drain-to-source on-resistance ($R_{DS(ON)}$) multiplied by the load current.

$$V_{DROPOUT} = V_{IN} - V_{OUT} = R_{DS(ON)} \times I_{OUT}$$

Package Outline

SOT-89

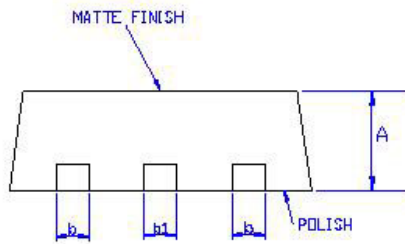
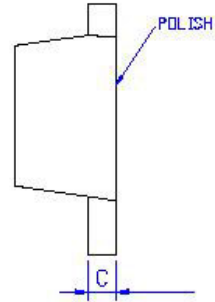
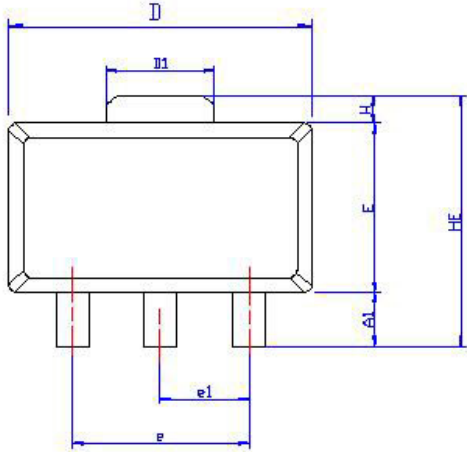

SYMBOLS	DIMENSIONS IN MILLIMETERS			DIMENSIONS IN INCHES		
	MIN	NOM	MAX	MIN	NOM	MAX
A	1.40	1.50	1.60	0.055	0.059	0.063
A1	0.80	1.04	—	0.031	0.041	—
b	0.36	0.42	0.48	0.014	0.016	0.018
b1	0.41	0.47	0.53	0.016	0.018	0.020
C	0.38	0.40	0.43	0.014	0.015	0.017
D	4.40	4.50	4.60	0.173	0.177	0.181
D1	1.40	1.60	1.75	0.055	0.062	0.069
HE	—	—	4.25	—	—	0.167
E	2.40	2.50	2.60	0.094	0.098	0.102
e	2.90	3.00	3.10	0.114	0.118	0.122
H	0.35	0.40	0.45	0.014	0.016	0.018
Σ	0.65	0.75	0.85	0.026	0.030	0.034
e1	1.40	1.50	1.60	0.054	0.059	0.063

TO-92

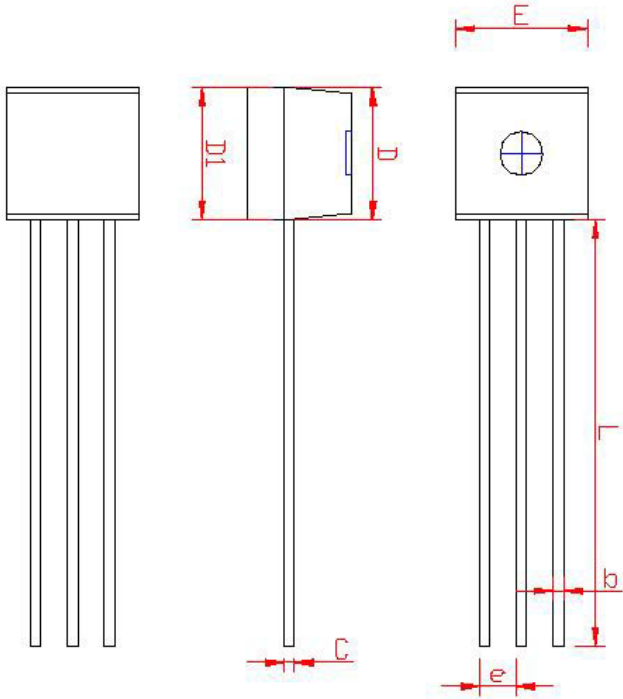

SYMBOL	MILLIMETERS		INCHES	
	MIN.	MAX.	MIN.	MAX.
	A	3.35	3.86	0.132
A1	1.0414	1.55	0.041	0.061
b	0.254	0.508	0.010	0.020
E	4.34	4.85	0.171	0.191
C	0.254	0.508	0.010	0.020
L	14.53	15.04	0.572	0.592
e	1.143	1.397	0.045	0.055
G	3.683	4.191	0.145	0.165
D	4.29	4.80	0.169	0.189
D1	4.34	4.85	0.171	0.191

