



Micro Commercial Components

Micro Commercial Components
 20736 Marilla Street Chatsworth
 CA 91311
 Phone: (818) 701-4933
 Fax: (818) 701-4939

SK82L THRU SK810L

8.0 Amp Schottky Rectifier 20 to 100 Volts

Features

- High Current Capability
- Extremely Low Thermal Resistance
- For Surface Mount Application
- Higher Temp Soldering: 250°C for 10 Seconds At Terminals
- Low Forward Voltage

Maximum Ratings

- Operating Temperature: -55°C to +150°C
- Storage Temperature: -55°C to +150°C
- Typical Thermal Resistance: 18°C/W Junction to Lead

MCC Catalog Number	Device Marking	Maximum Recurrent Peak Reverse Voltage	Maximum RMS Voltage	Maximum DC Blocking Voltage
SK82L	SK82L	20V	14V	20V
SK83L	SK83L	30V	21V	30V
SK835L	SK835L	35V	24.5V	35V
SK84L	SK84L	40V	28V	40V
SK845L	SK845L	45V	31.5V	45V
SK86L	SK86L	60V	42V	60V
SK88L	SK88L	80V	56V	80V
SK810L	SK810L	100V	70V	100V

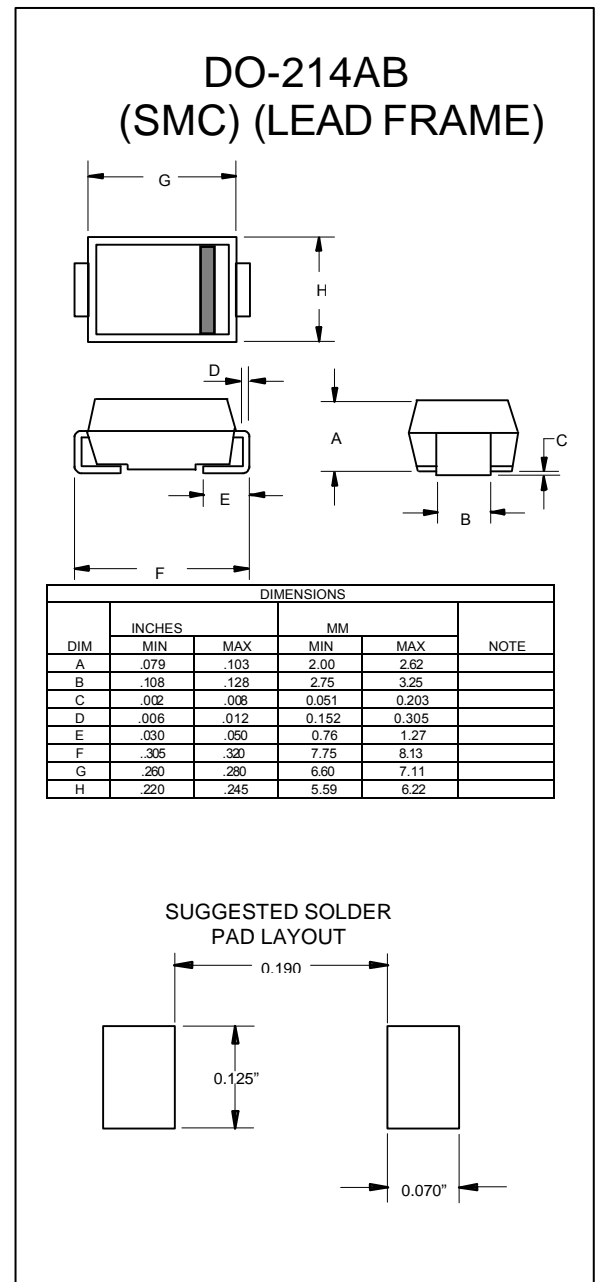

Electrical Characteristics @ 25°C Unless Otherwise Specified

Average Forward Current	$I_{F(AV)}$	8.0A	$T_J=95^\circ\text{C}$
Peak Forward Surge Current	I_{FSM}	200A	8.3ms half sine
Maximum Instantaneous Forward Voltage SK82L-86L SK88L-810L	V_F	.65V .80V	$I_{FM}=8.0A$ $T_A=25^\circ\text{C}$
Maximum DC Reverse Current At Rated DC Blocking Voltage	I_R	1mA 20mA	$T_J=25^\circ\text{C}$ $T_J=100^\circ\text{C}$
Typical Junction Capacitance	C_J	400pF	Measured at 1.0MHz, $V_R=4.0V$

SK82L thru SK810L

Figure 1
Typical Forward Characteristics

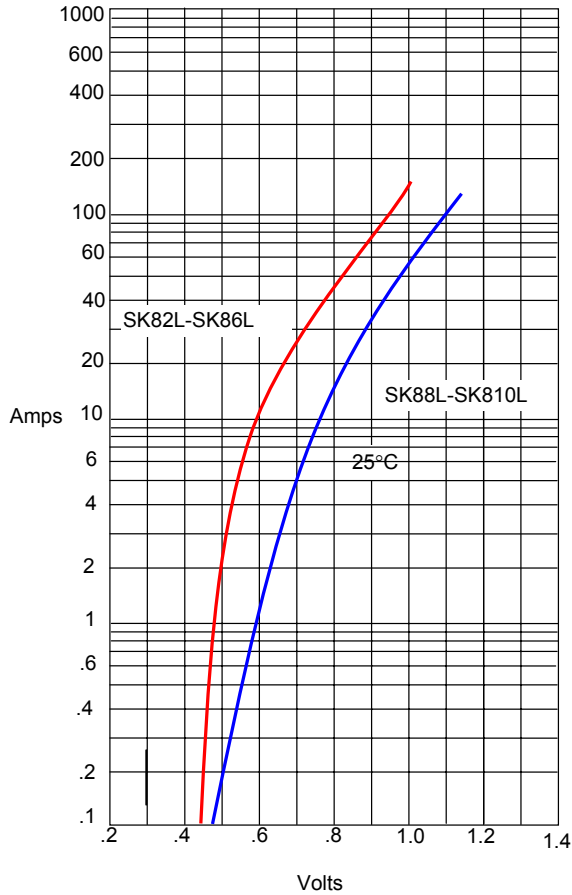

Instantaneous Forward Current - Amperes versus
Instantaneous Forward Voltage - Volts

Figure 2
Forward Derating Curve

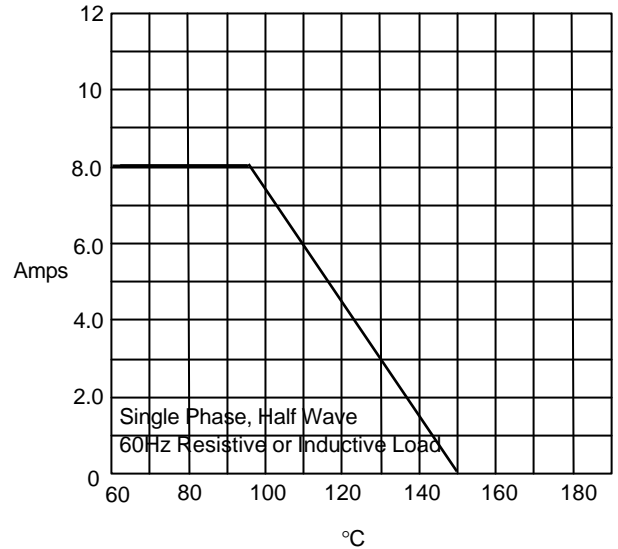

Average Forward Rectified Current - Amperes versus
Ambient Temperature - °C

Figure 3
Junction Capacitance

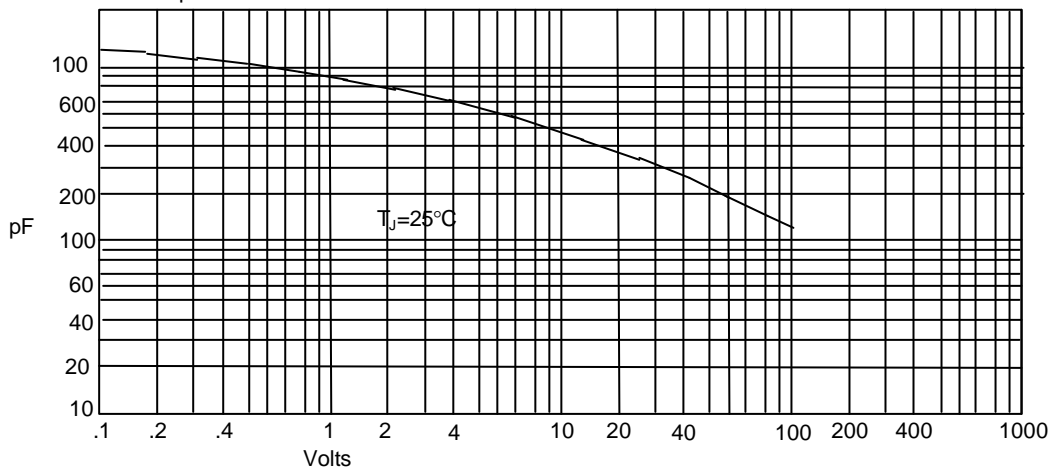

Junction Capacitance - pF versus
Reverse Voltage - Volts

SK82L thru SK810L

Figure 4
Typical Reverse Characteristics

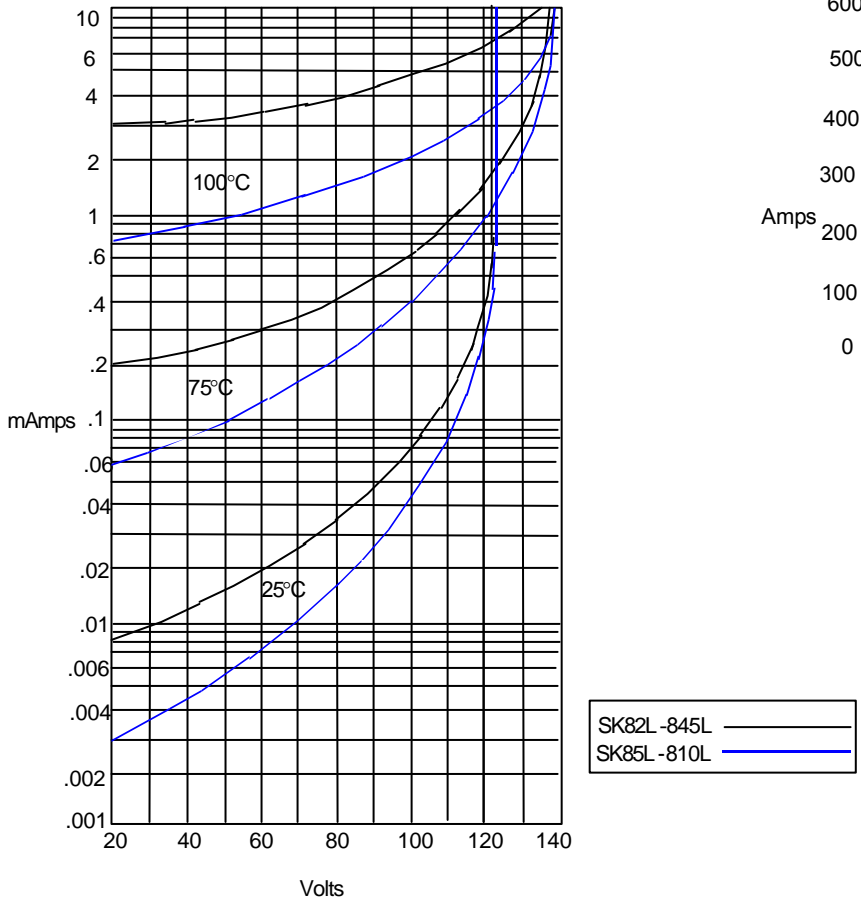

Instantaneous Reverse Leakage Current - MicroAmperes *versus* Percent Of Rated Peak Reverse Voltage - Volts

Figure 5
Peak Forward Surge Current

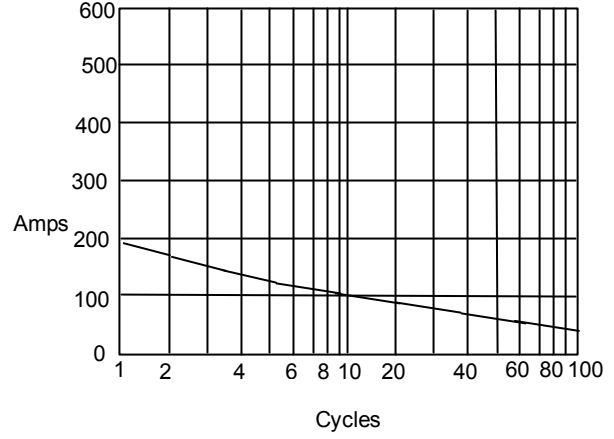

Peak Forward Surge Current - Amperes *versus* Number Of Cycles At 60Hz - Cycles