

**CD54/74HC646, CD54/74HCT646
CD54/74HC648, CD54/74HCT648**

File Number 1664

Advance Information/
Preliminary Data

High-Speed CMOS Logic

HARRIS SEMICOND SECTOR

27E D

4302271 0017851 7 HAS

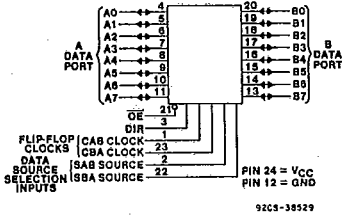

**Octal Bus Transceiver/Register,
3-State**

Type Features:

- Independent Registers for A and B Buses
- CD54/74HC/HCT646 Non-Inverting
CD54/74HC/HCT648 Inverting
- 3-State Outputs
- Drives 15LSTTL loads
- Typical Propagation Delay = 12ns (A ↔ B)
@ V_{CC} = 5 V, C_L = 15 pF, T_A = 25° C

FUNCTIONAL DIAGRAM

The RCA-CD54/74HC646 and CD54/74HCT646 are octal bus transceivers/registers with 3-state non-inverting outputs. The RCA-CD54/74HC648 and CD54/74HCT648 are octal bus transceivers/registers with 3-state inverting outputs. These devices are bus transceivers with D-type flip-flops which act as internal storage registers. Data on the A bus or the B bus can be clocked into the registers on the LOW-to-HIGH transition of either CAB or CBA clock inputs. Output enable (\overline{OE}) and direction (DIR) inputs control the transceiver functions. Data present at the high impedance output can be stored in either register or both but only one of the two buses can be enabled as outputs at any one time. The select controls (SAB and SBA) can multiplex stored and transparent (real time) data. The direction control determines which data bus will receive data when the output enable (\overline{OE}) is LOW. In the high impedance mode (output enable HIGH), A data can be stored in one register and B data can be stored in the other register. The clocks are not gated with the direction (DIR) and output enable (\overline{OE}) terminals; data at the A or B terminals can be clocked into the storage flip-flops at any time.

Family Features:

- Fanout (Over Temperature Range):
Standard Outputs - 10 LSTTL Loads
Bus Driver Outputs - 15 LSTTL Loads
- Wide Operating Temperature Range:
CD74HC/HCT: -40 to +85° C
- Balanced Propagation Delay and Transition Times
- Significant Power Reduction Compared to LSTTL Logic ICs
- Alternate Source is Philips/Signetics
- CD54HC/CD74HC Types:
2 to 6 V Operation
High Noise Immunity:
N_{IL} = 30%, N_{IH} = 30% of V_{CC}; @ V_{CC} = 5 V
- CD54HCT/CD74HCT Types:
4.5 to 5.5 V Operation
Direct LSTTL Input Logic Compatibility
V_{IL} = 0.8 V Max., V_{IH} = 2 V Min.
CMOS Input Compatibility
I_I ≤ 1 μA @ V_{OL}, V_{OH}

The CD54HC646, 648 and CD54HCT646, 648 are supplied in 24-lead dual-in-line frit-seal ceramic packages (F suffix). The CD74HC646, 648 and CD74HCT646, 648 are supplied in 24-lead dual-in-line, narrow-body plastic packages (EN suffix), in 24-lead dual-in-line, wide-body plastic packages (E suffix), and in 24-lead dual-in-line surface-mount plastic packages (M suffix). Both types are also available in chip form (H suffix).

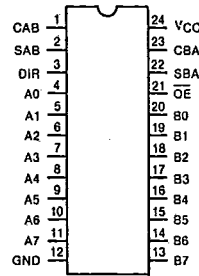

TERMINAL ASSIGNMENT

CD54/74HC646, CD54/74HCT646 CD54/74HC648, CD54/74HCT648

HARRIS SEMICONDUCTOR

27E D 4302271 0017852 9 HAS

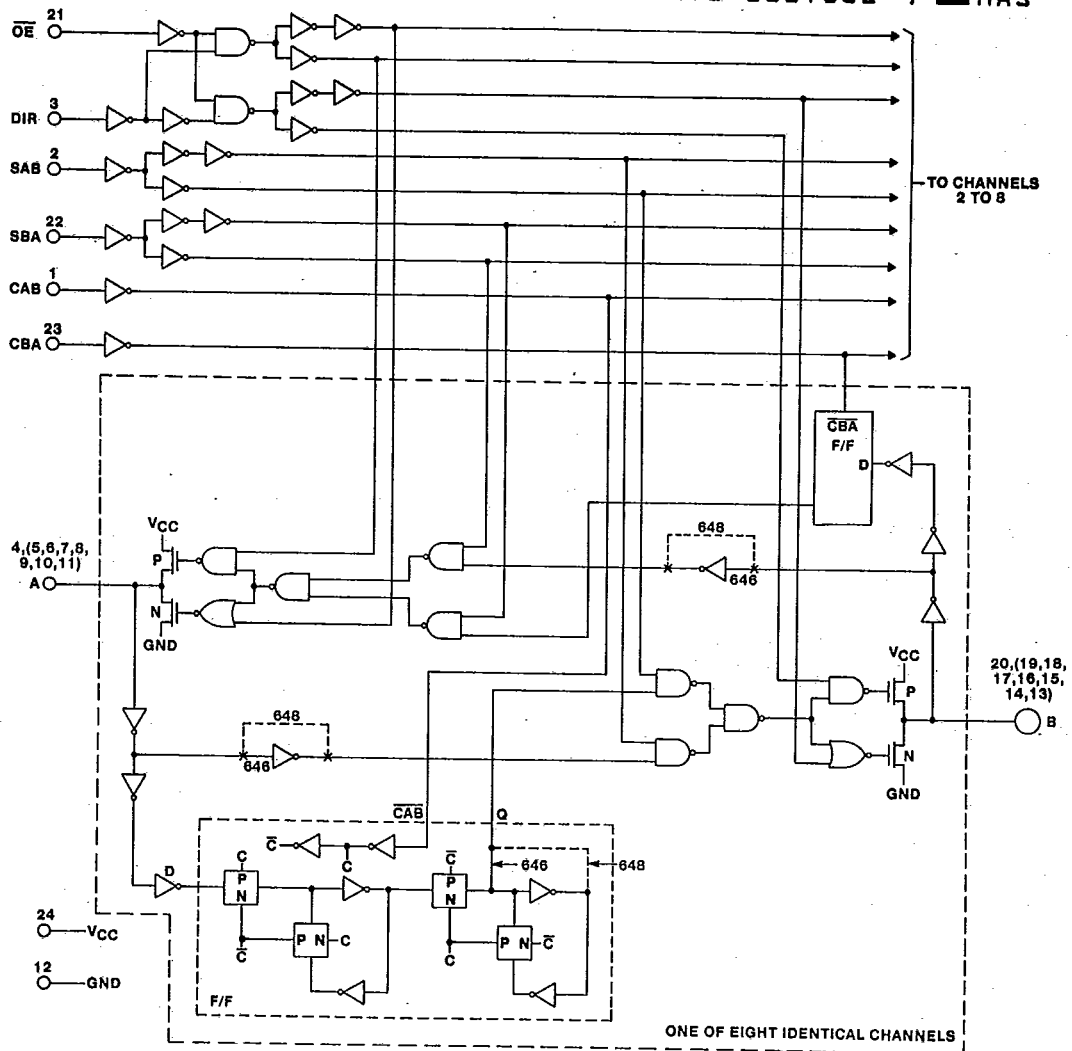

Fig. 1 — Logic Diagram.

CD54/74HC646, CD54/74HCT646
CD54/74HC648, CD54/74HCT648

FUNCTION TABLE

INPUTS						DATA I/O #		OPERATION OR FUNCTION	
OE	DIR	CAB	CBA	SAB	SBA	A0 THRU A7	B0 THRU B7	646	648
X	X	\overline{C}	X	X	X	Input	Not specified	Store A, B unspecified	Store A, B unspecified
X	X	X	\overline{C}	X	X	Not specified	Input	Store B, A unspecified	Store B, A unspecified
H	X	\overline{C}	\overline{C}	X	X	Input	Input	Store A and B Data Isolation, hold storage	Store A and B Data Isolation, hold storage
L	L	X	X	X	L	Output	Input	Real-Time B Data to A Bus	Real-Time \overline{B} Data to A Bus
L	L	X	H or L	X	H	Output	Input	Stored B Data to A Bus	Stored \overline{B} Data to A Bus
L	H	X	X	L	X	Input	Output	Real-Time A Data to B Bus	Real-Time \overline{A} Data to B Bus
L	H	H or L	X	H	X	Input	Output	Stored A Data to B Bus	Stored \overline{A} Data to B Bus

The data output functions may be enabled or disabled by various signals at the OE and DIR inputs. Data input functions are always enabled, i.e., data at the bus pins will be stored on every low-to-high transition on the clock inputs. To prevent excess currents in the High-Z modes all I/O terminals should be terminated with 10KΩ resistors.

MAXIMUM RATINGS, Absolute-Maximum Values:

DC SUPPLY-VOLTAGE, (V _{cc}):	-0.5 to +7 V
(Voltages referenced to ground)	
DC INPUT DIODE CURRENT, I _{IK} (FOR V _i < -0.5 V OR V _i > V _{cc} + 0.5V)	±20mA
DC OUTPUT DIODE CURRENT, I _{OK} (FOR V _o < -0.5 V OR V _o > V _{cc} + 0.5V)	±20mA
DC DRAIN CURRENT, PER OUTPUT (I _o) (FOR -0.5 V < V _o < V _{cc} + 0.5V)	±35mA
DC V _{cc} OR GROUND CURRENT (I _{cc})	±70mA
POWER DISSIPATION PER PACKAGE (P _o):	
For T _A = -40 to +60°C (PACKAGE TYPE E)	500 mW
For T _A = +60 to +85°C (PACKAGE TYPE E)	Derate Linearly at 8 mW/°C to 300 mW
For T _A = -55 to +100°C (PACKAGE TYPE F, H)	500 mW
For T _A = +100 to +125°C (PACKAGE TYPE F, H)	Derate Linearly at 8 mW/°C to 300 mW
For T _A = -40 to +70°C (PACKAGE TYPE M)	400 mW
For T _A = +70 to +125°C (PACKAGE TYPE M)	Derate Linearly at 6 mW/°C to 70 mW
OPERATING-TEMPERATURE RANGE (T _A):	
PACKAGE TYPE E, M	-40 to +85°C
PACKAGE TYPE F, H	-55 to +125°C
STORAGE TEMPERATURE (T _{stg})	-65 to +150°C
LEAD TEMPERATURE (DURING SOLDERING):	
At distance 1/16 ± 1/32 in. (1.59 ± 0.79 mm) from case for 10 s max.	-265°C
Unit inserted into a PC Board (min. thickness 1/16 in., 1.59 mm) with solder contacting lead tips only	-300°C

RECOMMENDED OPERATING CONDITIONS:

For maximum reliability, nominal operating conditions should be selected so that operation is always within the following ranges:

CHARACTERISTIC	LIMITS		UNITS
	MIN.	MAX.	
Supply-Voltage Range (For T _A = Full Package-Temperature Range) V _{cc} .*			
CD54/74HC Types	2	6	V
CD54/74HCT Types	4.5	5.5	V
DC Input or Output Voltage V _{IN} , V _{OUT}	0	V _{cc}	V
Operating Temperature T _A :			
CD74 Types	-40	+85	°C
CD54 Types	-55	+125	°C
Input Rise and Fall Times t _r , t _f			
at 2 V	0	1000	ns
at 4.5 V	0	500	ns
at 6 V	0	400	ns

*Unless otherwise specified, all voltages are referenced to Ground.

HAS
 0
 4302271 0017853 0
 27E D
 HARRIS SEMICONDUCTOR

**CD54/74HC646, CD54/74HCT646
CD54/74HC648, CD54/74HCT648**

STATIC ELECTRICAL CHARACTERISTICS

CHARACTERISTIC	CD74HC648/CD54HC646 CD74HC648/CD54HC648										CD74HCT648/CD54HCT646 CD74HCT648/CD54HCT648										UNITS													
	TEST CONDITIONS			74HC/54HC TYPES			74HC TYPES			54HC TYPES			TEST CONDITIONS		74HCT/54HCT TYPES			74HCT TYPES				54HCT TYPES												
	V _I V	I _O mA	V _{CC} V	+25°C			-40/ +85°C			-55/ +125°C			V _I V	V _{CC} V	+25°C			-40/ +85°C				-55/ +125°C												
				Min	Typ	Max	Min	Max	Min	Max	Min	Max			Min	Typ	Max	Min	Max	Min		Max												
High-Level Input Voltage V _{OH}			2	1.5	—	—	1.5	—	1.5	—	—	4.5			2	—	—	2	—	2	—	—	V											
			4.5	3.15	—	—	3.15	—	3.15	—	—	to			—	—	0.8	—	0.8	—	0.8	—	—	V										
			6	4.2	—	—	4.2	—	4.2	—	—	5.5			—	—	—	—	—	—	—	—	—	—	V									
Low-Level Input Voltage V _{IL}			2	—	—	0.5	—	0.5	—	0.5	—	4.5			—	—	—	0.8	—	0.8	—	0.8	—	V										
			4.5	—	—	1.35	—	1.35	—	1.35	—	to			—	—	0.8	—	0.8	—	0.8	—	—	V										
			6	—	—	1.8	—	1.8	—	1.8	—	5.5			—	—	—	—	—	—	—	—	—	—	V									
High-Level Output Voltage V _{OH} CMOS Loads	V _{IL} or V _{OH}	-0.02	2	1.9	—	—	1.9	—	1.9	—	V _{IL} or V _{OH}	4.5	4.4	—	—	4.4	—	4.4	—	4.4	—	—	V											
			4.5	4.4	—	—	4.4	—	4.4	—	—													4.5	3.98	—	—	3.84	—	3.7	—	—	V	
			6	5.9	—	—	5.9	—	5.9	—	—													4.5	3.98	—	—	3.84	—	3.7	—	—	—	V
TTL Loads (Bus Driver)	V _{IL} or V _{OH}	-6 -7.8	4.5	3.98	—	—	3.84	—	3.7	—	V _{IL} or V _{OH}	4.5	3.98	—	—	3.84	—	3.7	—	—	—	V												
			6	5.48	—	—	5.34	—	5.2	—	—												4.5	3.98	—	—	3.84	—	3.7	—	—	V		
			6	5.48	—	—	5.34	—	5.2	—	—												4.5	3.98	—	—	3.84	—	3.7	—	—	—	V	
Low-Level Output Voltage V _{OL} CMOS Loads	V _{IL} or V _{OH}	0.02	2	—	—	0.1	—	0.1	—	0.1	V _{IL} or V _{OH}	4.5	—	—	0.1	—	0.1	—	0.1	—	0.1	—	V											
			4.5	—	—	0.1	—	0.1	—	0.1	—													—	—	—	0.1	—	0.1	—	0.1	—	—	V
			6	—	—	0.1	—	0.1	—	0.1	—													—	—	—	—	0.1	—	0.1	—	0.1	—	—
TTL Loads (Bus Driver)	V _{IL} or V _{OH}	6 7.8	4.5	—	—	0.26	—	0.33	—	0.4	V _{IL} or V _{OH}	4.5	—	—	0.26	—	0.33	—	0.4	—	—	—	V											
			6	—	—	0.26	—	0.33	—	0.4	—													—	—	—	0.26	—	0.33	—	0.4	—	—	V
			6	—	—	0.26	—	0.33	—	0.4	—													—	—	—	0.26	—	0.33	—	0.4	—	—	V
Input Leakage Current I _I	V _{CC} or Gnd		6	—	—	±0.1	—	±1	—	±1	Any Voltage Between V _{CC} & Gnd	5.5	—	—	±0.1	—	±1	—	±1	—	±1	μA												
Quiescent Device Current I _{CC}	V _{CC} or Gnd	0	6	—	—	8	—	80	—	160	V _{CC} or Gnd	5.5	—	—	8	—	80	—	160	—	160	μA												
Additional Quiescent Device Current per input pin: 1 unit load ΔI _{CC} *											V _{CC} -2.1 5.5	4.5 to 5.5	—	100	360	—	450	—	490	—	490	μA												
3-State Leakage Current I _{OZ}	V _{IL} or V _{OH}	V _O = V _{CC} or Gnd	6	—	—	±0.5	—	±5.0	—	±10	V _{IL} or V _{OH}	4.5 5.5	—	—	±0.5	—	±5.0	—	±10	—	±10	μA												

*For dual-supply systems theoretical worst case (V_I = 2.4 V, V_{CC} = 5.5 V) specification is 1.8 mA.

HCT Input Loading Table

Input	Unit Loads*
OE	1.3
DIR	0.75
Clock A → B, B → A	0.6
Select A, Select B	0.45
Inputs A0-A7, B0-B7	0.3

*Unit Load is ΔI_{CC} limit specified in Static Characteristic Chart, e.g., 360 μA max. @ 25°C.

HARRIS SEMICONDUCTOR 27E D 430227J 0017854 2 HAS

CD54/74HC646, CD54/74HCT646
CD54/74HC648, CD54/74HCT648

SWITCHING CHARACTERISTICS ($V_{CC} = 5\text{ V}$, $T_A = 25^\circ\text{C}$, Input $t_r, t_f = 6\text{ ns}$)

CHARACTERISTIC	C_L (pF)	TYPICAL		UNITS	
		HC	HCT		
Propagation Delays	t_{PLH}, t_{PHL}	15	18	18	ns
Store A Data to B Bus (646)	t_{PLH}, t_{PHL}	15	18	18	ns
Store B Data to A Bus (646)	t_{PLH}, t_{PHL}	15	20	23	ns
Store \bar{A} Data to B Bus (648)	t_{PLH}, t_{PHL}	15	20	23	ns
Store \bar{B} Data to A Bus (648)	t_{PLH}, t_{PHL}	15	12	15	ns
A Data to B Bus (646)	t_{PLH}, t_{PHL}	15	12	15	ns
B Data to A Bus (646)	t_{PLH}, t_{PHL}	15	12	15	ns
\bar{A} Data to B Bus (648)	t_{PLH}, t_{PHL}	15	12	15	ns
\bar{B} Data to A Bus (648)	t_{PLH}, t_{PHL}	15	12	15	ns
Select to Data (646)	t_{PLH}, t_{PHL}	15	14	19	ns
Select to Data (648)	t_{PLH}, t_{PHL}	15	16	19	ns
3-State Disabling Time	t_{PLZ}, t_{PHZ}	15	14	14	ns
3-State Enabling Time	t_{PZL}, t_{PZH}	15	14	19	ns
Max Frequency	f_{max}	15	60	45	MHz
Power Dissipation Capacitance*	C_{PD}	—	52	52	pF

* C_{PD} is used to determine the dynamic power consumption, per package.
 $P_D = V_{CC}^2 C_{PD} f_i + \sum V_{CC}^2 C_L f_o$ where:
 C_L = output load capacitance
 V_{CC} = supply voltage
 f_i = input frequency
 f_o = output frequency

PREREQUISITE FOR SWITCHING FUNCTION

CHARACTERISTIC	V_{CC}	25°C				-40°C to +85°C				-55°C to +125°C				UNITS
		HC		HCT		74HC		74HCT		54HC		54HCT		
		Min.	Max.	Min.	Max.	Min.	Max.	Min.	Max.	Min.	Max.	Min.	Max.	
Maximum Frequency f_{max}	2	6	—	—	—	5	—	—	—	4	—	—	—	MHz
	4.5	30	—	25	—	25	—	20	—	20	—	17	—	
	6	35	—	—	—	29	—	—	—	23	—	—	—	
Set Up Time Data to Clock t_{su}	2	60	—	—	—	75	—	—	—	90	—	—	—	ns
	4.5	12	—	12	—	15	—	15	—	18	—	18	—	
	6	10	—	—	—	13	—	—	—	15	—	—	—	
Hold Time Data to Clock t_h	2	35	—	—	—	45	—	—	—	55	—	—	—	ns
	4.5	7	—	5	—	9	—	5	—	11	—	5	—	
	6	6	—	—	—	8	—	—	—	9	—	—	—	
Clock Pulse Width t_w	2	80	—	—	—	100	—	—	—	120	—	—	—	ns
	4.5	16	—	25	—	20	—	31	—	24	—	38	—	
	6	14	—	—	—	17	—	—	—	20	—	—	—	

HARRIS SEMICONDUCTOR 27E D 4302271 0017855 4 HAS

**CD54/74HC646, CD54/74HCT646
CD54/74HC648, CD54/74HCT648**

SWITCHING CHARACTERISTICS ($C_L = 50$ pF, Input $t_r, t_f = 6$ ns)

CHARACTERISTIC	V_{CC}	25°C				-40°C to +85°C				-55°C to +125°C				UNITS	
		HC		HCT		74HC		74HCT		54HC		54HCT			
		Min.	Max.	Min.	Max.	Min.	Max.	Min.	Max.	Min.	Max.	Min.	Max.		
Propagation Delay, Store A data to B bus	t_{PLH}	2	—	220	—	—	—	275	—	—	—	330	—	—	ns
Store A data to B bus	t_{PLH}	4.5	—	44	—	44	—	55	—	55	—	66	—	66	
Store B data to B bus (646)	t_{PHL}	6	—	37	—	—	—	47	—	—	—	5.6	—	—	
Store A data to B bus	t_{PLH}	2	—	240	—	—	—	300	—	—	—	360	—	—	ns
Store B data to A Bus	t_{PHL}	4.5	—	48	—	54	—	60	—	68	—	72	—	81	
(648)	t_{PHL}	6	—	41	—	—	—	51	—	—	—	61	—	—	
A data to B bus	t_{PLH}	2	—	135	—	—	—	170	—	—	—	205	—	—	ns
B data to A Bus	t_{PHL}	4.5	—	27	—	37	—	34	—	46	—	41	—	56	
(646)	t_{PHL}	6	—	23	—	—	—	29	—	—	—	35	—	—	
A data to B bus	t_{PLH}	2	—	150	—	—	—	190	—	—	—	225	—	—	ns
B data to A Bus	t_{PHL}	4.5	—	30	—	37	—	38	—	46	—	45	—	56	
(648)	t_{PHL}	6	—	26	—	—	—	33	—	—	—	38	—	—	
Select to Data	t_{PLH}	2	—	170	—	—	—	215	—	—	—	255	—	—	ns
(646)	t_{PHL}	4.5	—	34	—	46	—	43	—	58	—	51	—	69	
	t_{PHL}	6	—	29	—	—	—	37	—	—	—	43	—	—	
Select to Data	t_{PLH}	2	—	190	—	—	—	240	—	—	—	285	—	—	ns
(648)	t_{PHL}	4.5	—	38	—	46	—	48	—	58	—	57	—	69	
	t_{PHL}	6	—	32	—	—	—	39	—	—	—	48	—	—	
3-State Disabling Time Bus to Output or Register to Output	t_{PLZ}	2	—	175	—	—	—	220	—	—	—	265	—	—	ns
	t_{PHZ}	4.5	—	35	—	35	—	44	—	44	—	53	—	53	
	t_{PHZ}	6	—	30	—	—	—	37	—	—	—	45	—	—	
3-State Enabling Time Bus to Output or Register to Output	t_{PZL}	2	—	175	—	—	—	220	—	—	—	265	—	—	ns
	t_{PZH}	4.5	—	35	—	45	—	44	—	56	—	53	—	68	
	t_{PZH}	6	—	30	—	—	—	37	—	—	—	45	—	—	
Output Transition Time	t_{TLH}	2	—	60	—	—	—	75	—	—	—	90	—	—	ns
	t_{THL}	4.5	—	12	—	12	—	15	—	15	—	18	—	18	
	t_{THL}	6	—	10	—	—	—	13	—	—	—	15	—	—	
3-State Output Capacitance	C_o	—	—	—	—	—	—	—	—	—	—	—	—	—	pF
Input Capacitance	C_i	—	—	10	—	10	—	10	—	10	—	10	—	10	pF

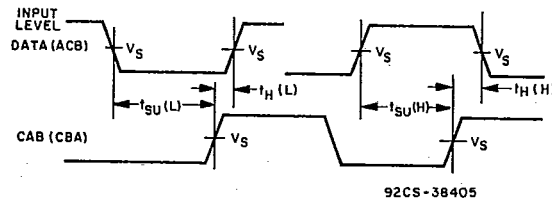
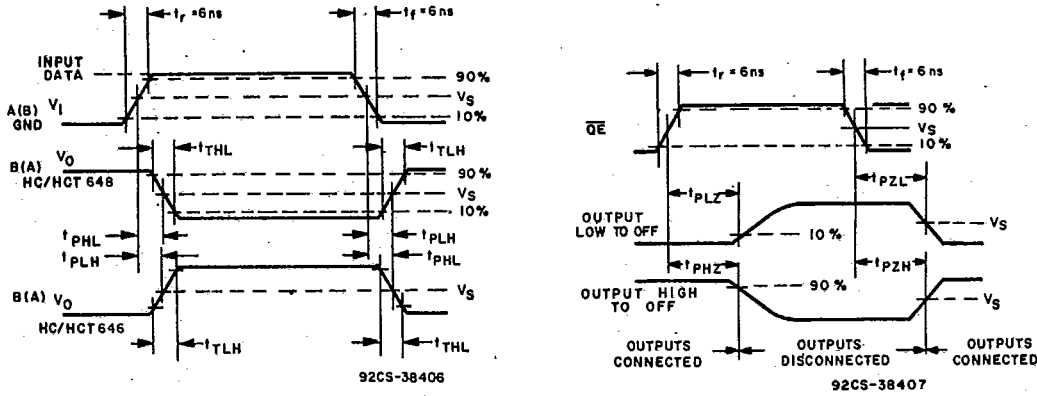

Fig. 2 — Data setup and hold times.

CD54/74HC646, CD54/74HCT646
CD54/74HC648, CD54/74HCT648

HARRIS SEMICONDUCTOR 27E D 4302271 0017857 & HAS



	54/74HC	54/74HCT
Input Level	V _{CC}	3V
Switching Voltage, V _s	50% V _{CC}	1.3 V

Fig. 3 — Transition times and propagation delay times.