



TL084

LINEAR INTEGRATED CIRCUIT

LOW NOISE QUAD J-FET OPERATIONAL AMPLIFIER

DESCRIPTION

The UTC **TL084** is a high speed J-FET input quad operational amplifier. It incorporates well matched, high voltage J-FET and bipolar transistors on a monolithic integrated circuit. The device features high slew rates, low input bias and offset current, and low offset voltage temperature coefficient.

FEATURES

- * Low Power Consumption
- * Wide Common-Mode (Up To V_{CC+}) and Differential Voltage Range
- * Low Input Bias and Offset Current
- * Low Noise $e_n = 15nV/\sqrt{Hz}$ (typ.)
- * Output Short-Circuit Protection
- * High Input Impedance J-FET Input Stage
- * Low Harmonic Distortion: 0.01% (typ.)
- * Internal Frequency Compensation
- * Latch up Free Operation

ORDERING INFORMATION

Ordering Number		Package	Packing
Lead Free	Halogen Free		
TL084L-D14-T	TL084G-D14-T	DIP-14	Tube
TL084L-S14-R	TL084G-S14-R	SOP-14	Tape Reel
TL084L-P14-R	TL084G-P14-R	TSSOP-14	Tape Reel

<p>TL084G-D14-T</p> <ul style="list-style-type: none"> (1) Packing Type (2) Package Type (3) Green Package 	<p>(1) T: Tube, R: Tape Reel (2) D14: DIP-14, S14: SOP-14, P14: TSSOP-14 (3) G: Halogen Free and Lead Free, L: Lead Free</p>
---	--

MARKING

DIP-14	SOP-14 / TSSOP-14
<p>Date Code</p> <p>L: Lead Free</p> <p>G: Halogen Free</p> <p>Lot Code</p>	<p>Date Code</p> <p>L: Lead Free</p> <p>G: Halogen Free</p> <p>Lot Code</p>

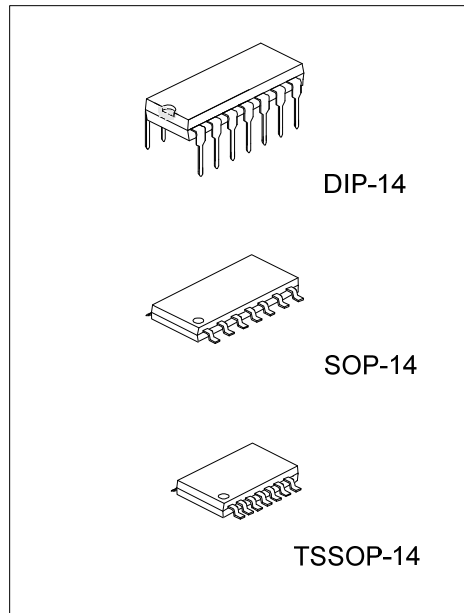

■ PIN CONFIGURATIONS

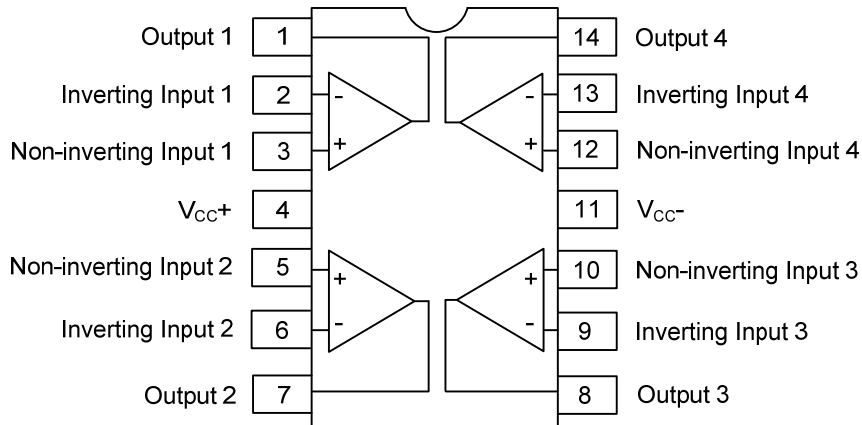

■ SCHEMATIC DIAGRAM

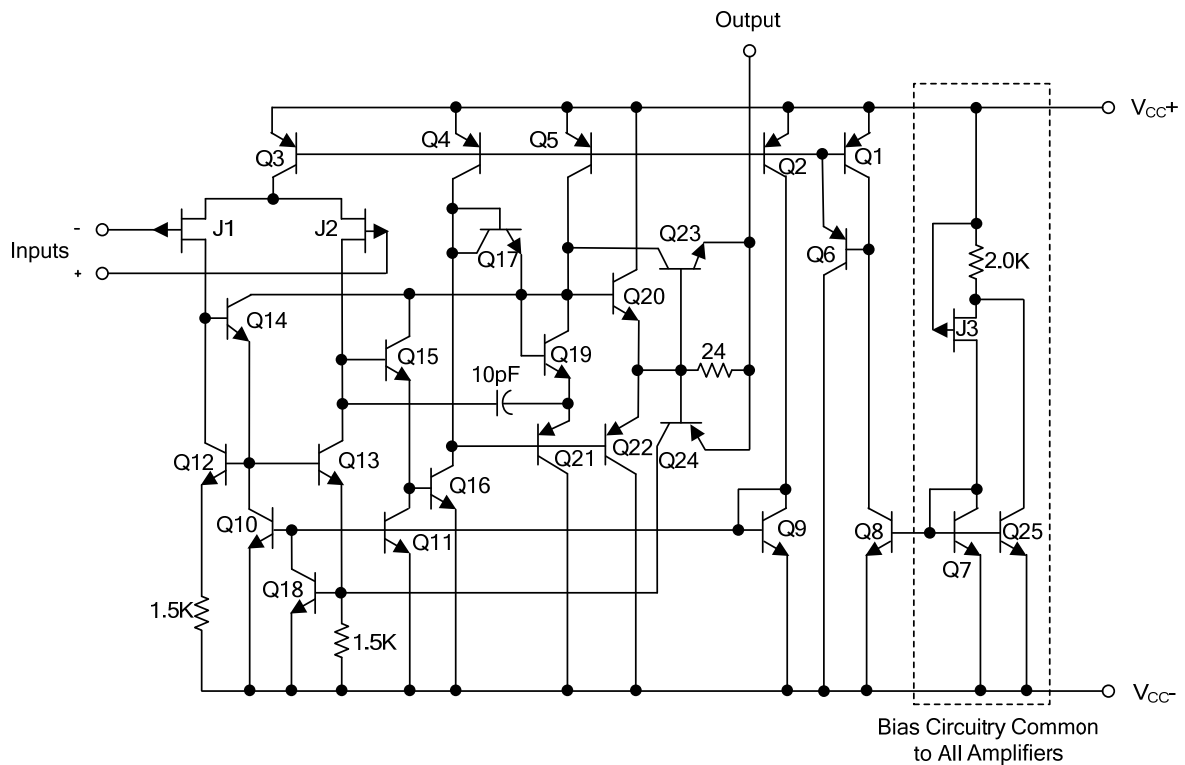

■ ABSOLUTE MAXIMUM RATINGS (T_A=25°C, unless otherwise specified)

PARAMETER	SYMBOL	RATING	UNIT	
Supply Voltage (Note 2)	V _{CC}	±18	V	
Input Voltage (Note 3)	V _{IN}	±15	V	
Differential Input Voltage (Note 4)	V _{I(DIFF)}	±30	V	
Power Dissipation	DIP-14	P _D	800	mW
	SOP-14		580	mW
	TSSOP-14		460	mW
Output Short-Circuit Duration (Note 5)		Infinite		
Operating Temperature	T _{OPR}	-40 ~ +125 (Note 6)	°C	
Storage Temperature	T _{STG}	-65 ~ +150	°C	

- Notes: 1. Absolute maximum ratings are those values beyond which the device could be permanently damaged. Absolute maximum ratings are stress ratings only and functional device operation is not implied.
2. All voltage values, except differential voltage, are with respect to the zero reference level (ground) of the supply voltages where the zero reference level is the midpoint between V_{CC-} and V_{CC+}.
3. The magnitude of the input voltage must never exceed the magnitude of the supply voltage or 15 volts, whichever is less.
4. Differential voltages are at the non-inverting input terminal with respect to the inverting input terminal.
5. The output may be shorted to ground or to either supply. Temperature and/or supply voltages must be limited to ensure that the dissipation rating is not exceeded.
6. It is guarantee by design, not 100% be tested.

■ ELECTRICAL CHARACTERISTICS (V_{CC}=±15V, T_A=25°C, unless otherwise specified)

PARAMETER	SYMBOL	TEST CONDITIONS	MIN	TYP	MAX	UNIT
Input Offset Voltage	V _{I(OFF)}	R _S ≤ 10kΩ, V _{CM} =0V		5	15	mV
Temperature Coefficient of Input Offset Voltage	ΔV _{I(OFF)}	R _S =50Ω		10		μV/°C
Input Offset Current (Note)	I _{I(OFF)}	V _{CM} =0V		5	200	pA
Input Bias Current (Note1)	I _{I(BIAS)}	V _{CM} =0V		30	400	pA
Input Common Mode Voltage	V _{I(CM)}		±10	-12~+15		V
Output Voltage Swing	V _{O(SW)}	T _A =25°C, R _L =2kΩ,	±10	±12		V
		T _A =25°C, R _L =10kΩ	±12	±13.5		V
		T _{MIN} ≤ T _A ≤ T _{MAX} , R _L =2kΩ	±10			V
		T _{MIN} ≤ T _A ≤ T _{MAX} , R _L =10kΩ	±12			V
Large Signal Voltage Gain	G _V	R _L ≥ 2kΩ, V _{OUT} =±10V	25	150		V/mV
Gain Bandwidth Product	GB _W			1		MHz
Input Resistance	R _{IN}			10 ¹²		Ω
Common Mode Rejection Ratio	CMR	R _S ≤ 10kΩ	70	100		dB
Supply Voltage Rejection Ratio	SVR	R _S ≤ 10kΩ	70	100		dB
Supply Current	I _{CC}	No Load		1.4	2.8	mA
Channel Separation	V01/V02	G _V =100		120		dB
Slew Rate	SR	V _{IN} =10V, R _L =2kΩ, C _L =100pF, unity gain	2.0			V/μs
Rise Time	t _R			0.1		μs
Overshoot Factor	K _{OV}	V _{IN} =20mV, R _L =2kΩ, C _L =100pF, unity gain		10		%
Equivalent Input Noise Voltage	eN	R _S =100Ω, f=1KHz		25		nV/√Hz

Note: The Input bias currents are junction leakage currents, which approximately double for every 10°C increase in the junction temperature.

■ PARAMETER MEASUREMENT INFORMATION

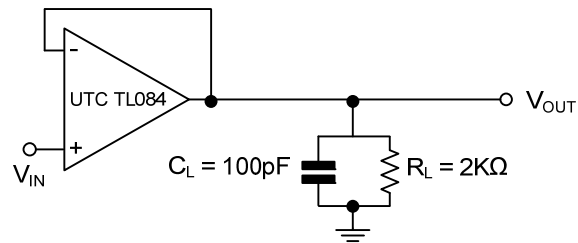

Voltage Follow

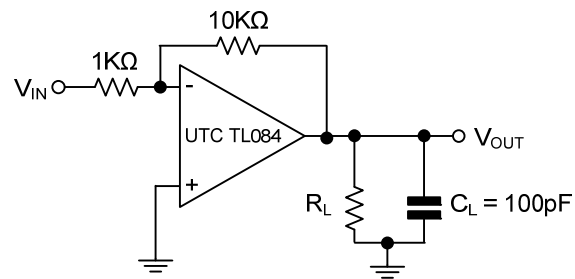

Gain-of-10 Inverting Amplifier

■ TYPICAL CHARACTERISTICS

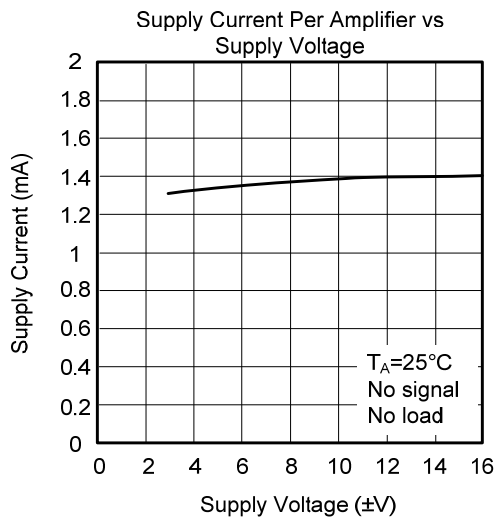
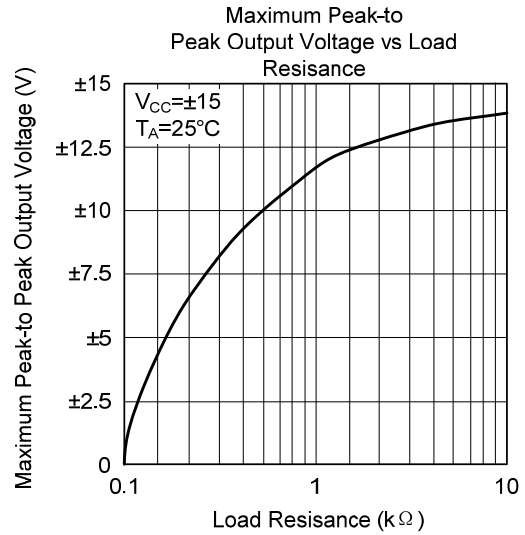
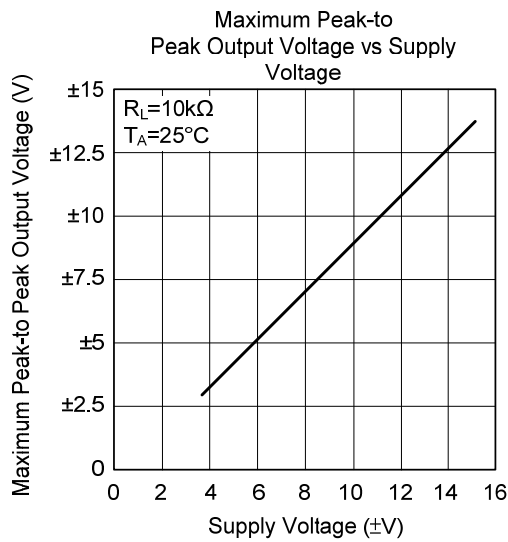
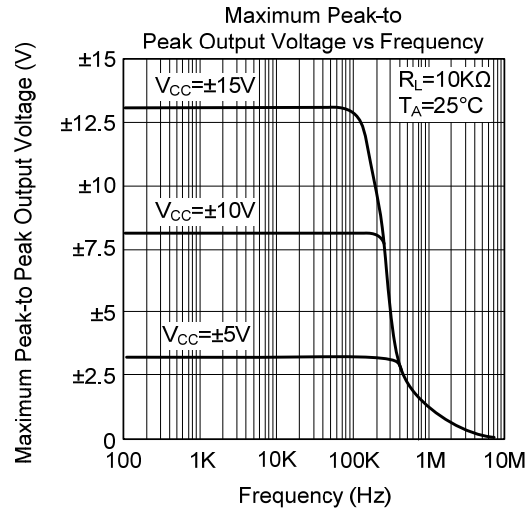
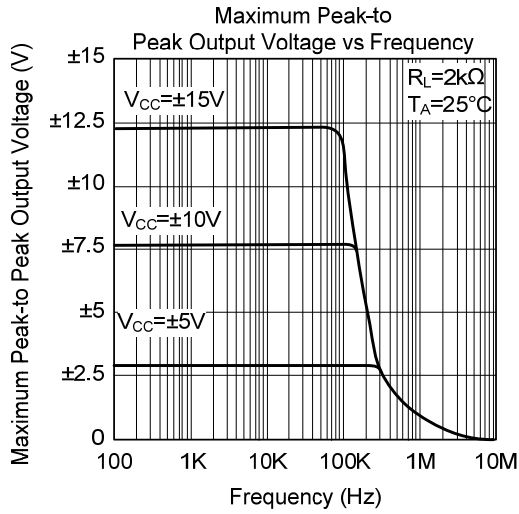

UTC assumes no responsibility for equipment failures that result from using products at values that exceed, even momentarily, rated values (such as maximum ratings, operating condition ranges, or other parameters) listed in products specifications of any and all UTC products described or contained herein. UTC products are not designed for use in life support appliances, devices or systems where malfunction of these products can be reasonably expected to result in personal injury. Reproduction in whole or in part is prohibited without the prior written consent of the copyright owner. UTC reserves the right to make changes to information published in this document, including without limitation specifications and product descriptions, at any time and without notice. This document supersedes and replaces all information supplied prior to the publication hereof.