

# Quad 2-input AND gate

## 74ALS08

TYPE	TYPICAL PROPAGATION DELAY	TYPICAL SUPPLY CURRENT (TOTAL)
74ALS08	5.0ns	1.8mA

### PIN CONFIGURATION

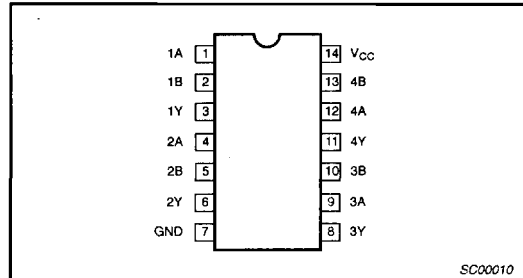

### ORDERING INFORMATION

DESCRIPTION	ORDER CODE	DRAWING NUMBER
	COMMERCIAL RANGE V <sub>CC</sub> = 5V ±10%, T <sub>amb</sub> = 0°C to +70°C	
14-pin plastic DIP	74ALS08N	SOT27-1
14-pin plastic SO	74ALS08D	SOT108-1
14-pin plastic SSOP Type II	74ALS08DB	SOT337-1

### INPUT AND OUTPUT LOADING AND FAN-OUT TABLE

PINS	DESCRIPTION	74ALS (U.L.) HIGH/LOW	LOAD VALUE HIGH/LOW
nA, nB	Data inputs	1.0/1.0	20µA/0.1mA
nY	Data outputs	20/80	0.4mA/8mA

NOTE: One (1.0) ALS unit load is defined as: 20µA in the High state and 0.1mA in the Low state.

### LOGIC SYMBOL

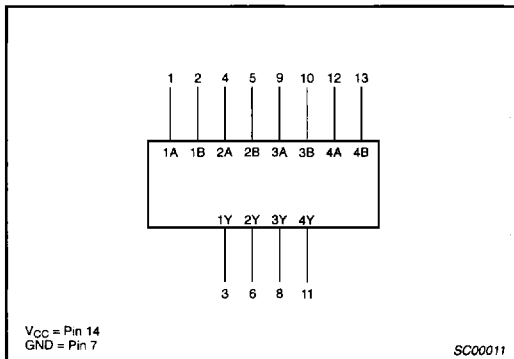

### IEC/IEEE SYMBOL

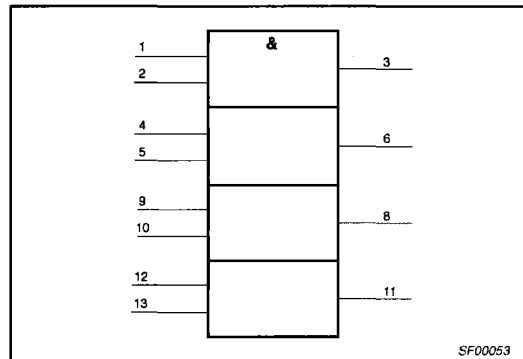

### LOGIC DIAGRAM

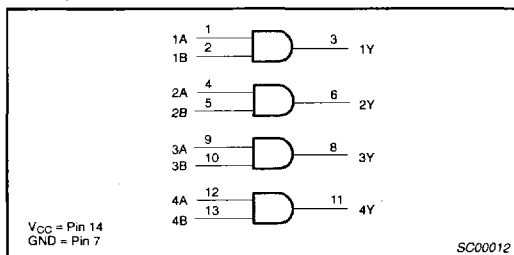

### FUNCTION TABLE

INPUTS		OUTPUT
nA	nB	nY
H	H	L
L	X	H
X	L	H

H = High voltage level  
L = Low voltage level  
X = Don't care

## Quad 2-input AND gate

74ALS08

**ABSOLUTE MAXIMUM RATINGS**

(Operation beyond the limit set forth in this table may impair the useful life of the device.  
Unless otherwise noted these limits are over the operating free-air temperature range.)

SYMBOL	PARAMETER	RATING	UNIT
$V_{CC}$	Supply voltage	-0.5 to +7.0	V
$V_{IN}$	Input voltage	-0.5 to +7.0	V
$I_{IN}$	Input current	-30 to +5	mA
$V_{OUT}$	Voltage applied to output in High output state	-0.5 to $V_{CC}$	V
$I_{OUT}$	Current applied to output in Low output state	16	mA
$T_{amb}$	Operating free-air temperature range	0 to +70	°C
$T_{stg}$	Storage temperature range	-65 to +150	°C

**RECOMMENDED OPERATING CONDITIONS**

SYMBOL	PARAMETER	LIMITS			UNIT
		MIN	NOM	MAX	
$V_{CC}$	Supply voltage	4.5	5.0	5.5	V
$V_{IH}$	High-level input voltage	2.0			V
$V_{IL}$	Low-level input voltage			0.8	V
$I_{IK}$	Input clamp current			-18	mA
$I_{OH}$	High-level output current			-0.4	mA
$I_{OL}$	Low-level output current			8	mA
$T_{amb}$	Operating free-air temperature range	0		+70	°C

**DC ELECTRICAL CHARACTERISTICS**

(Over recommended operating range unless otherwise noted.)

SYMBOL	PARAMETER	TEST CONDITIONS <sup>1</sup>	LIMITS			UNIT
			MIN	TYP <sup>2</sup>	MAX	
$V_{OH}$	High-level output voltage	$V_{CC} \pm 10\%$ , $V_{IL} = \text{MAX}$ , $V_{IH} = \text{MIN}$ , $I_{OH} = -0.4\text{mA}$	$V_{CC} - 2$			V
$V_{OL}$	Low-level output voltage	$V_{CC} = \text{MIN}$ , $V_{IL} = \text{MAX}$ , $V_{IH} = \text{MIN}$		0.25	0.40	V
			$I_{OL} = 4\text{mA}$	0.35	0.50	V
$V_{IK}$	Input clamp voltage	$V_{CC} = \text{MIN}$ , $I_I = I_{IK}$		-0.73	-1.5	V
$I_I$	Input current at maximum input voltage	$V_{CC} = \text{MAX}$ , $V_I = 7.0\text{V}$			0.1	mA
$I_{IH}$	High-level input current	$V_{CC} = \text{MAX}$ , $V_I = 2.7\text{V}$			20	$\mu\text{A}$
$I_{IL}$	Low-level input current	$V_{CC} = \text{MAX}$ , $V_I = 0.5\text{V}$			-0.1	mA
$I_O$	Output current <sup>3</sup>	$V_{CC} = \text{MAX}$ , $V_O = 2.25\text{V}$	-30		-112	mA
$I_{CC}$	Supply current (total)	$V_{CC} = \text{MAX}$	$V_I = 4.5\text{V}$	1.3	2.4	mA
			$V_I = 0\text{V}$	2.2	4.0	mA

**NOTES:**

- For conditions shown as MIN or MAX, use the appropriate value specified under recommended operating conditions for the applicable type.
- All typical values are at  $V_{CC} = 5\text{V}$ ,  $T_{amb} = 25^\circ\text{C}$ .
- The output conditions have been chosen to produce a current that closely approximate one half of the true short-circuit output current,  $I_{OS}$ .

# Quad 2-input AND gate

74ALS08

## AC ELECTRICAL CHARACTERISTICS

SYMBOL	PARAMETER	TEST CONDITION	LIMITS		UNIT
			$T_{amb} = 0^{\circ}\text{C to } +70^{\circ}\text{C}$ $V_{CC} = +5.0\text{V} \pm 10\%$ $C_L = 50\text{pF}, R_L = 500\Omega$		
			MIN	MAX	
$t_{PLH}$ $t_{PHL}$	Propagation delay nA or nB to nY	Waveform 1	2.0 3.0	14.0 10.0	ns

## AC WAVEFORMS

For all waveforms,  $V_M = 1.3\text{V}$ .

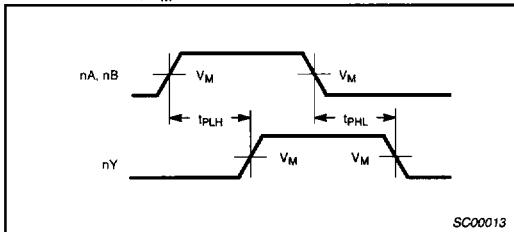

Waveform 1. Propagation Delay for Data to Output

## TEST CIRCUIT AND WAVEFORMS

**Test Circuit for Totem-pole Outputs**

**DEFINITIONS:**  
 $R_L$  = Load resistor; see AC electrical characteristics for value.  
 $C_L$  = Load capacitance includes jig and probe capacitance; see AC electrical characteristics for value.  
 $R_T$  = Termination resistance should be equal to  $Z_{OUT}$  of pulse generators.

**Input Pulse Definition**

Family	INPUT PULSE REQUIREMENTS					
	Amplitude	$V_M$	Rep.Rate	$t_w$	$t_{TLH}$	$t_{THL}$
74ALS	3.5V	1.3V	1MHz	500ns	2.0ns	2.0ns

SC00005