HN62338B Series

High Speed 1048576-word \times 8-bit CMOS Mask Programmable
ROM

HITACHI

Description

The HN62338B is a 8-Mbit CMOS mask-programmable ROM organized as 1048576 words by 8 bits. In addition, the HN62338B, which provides large capacity of 8M bits, is ideally suited for kanji character generators.

Features

- Single +5V power supply
- Maximum access time: 150 ns (max)
Low power consumption: 250 mW (typ) active 5 μ W (typ) standby
- Byte-wide data organization
- Pin compatible with JEDEC

Ordering Information

Type No.	Access Time	Package
HN62338BP-15	150 ns	600 mil 32-pin plastic DIP (DP-32)
HN62338BF-15	150 ns	32-pin plastic SOP (FP-32D)

HN62338B Series

Pin Arrangement

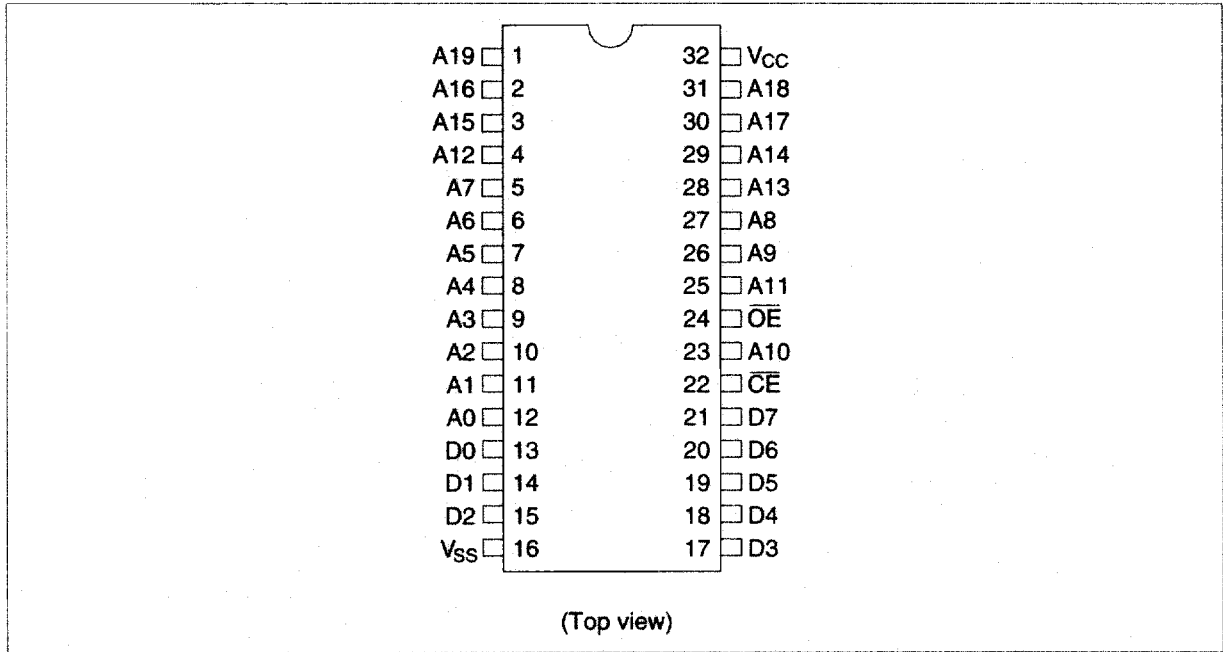

Block Diagram

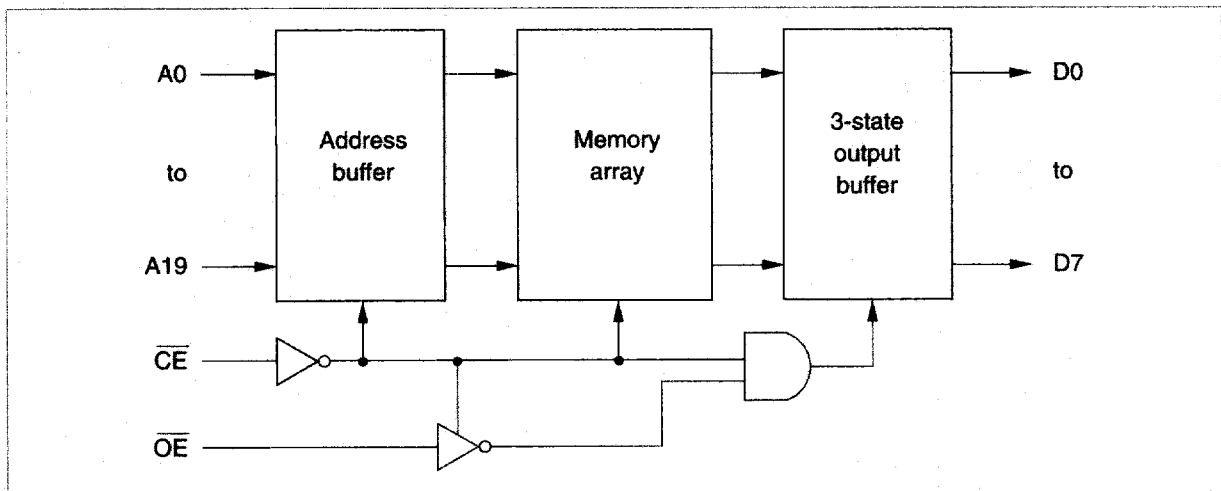

Absolute Maximum Ratings

Parameter	Symbol	Value	Unit	Note
Supply voltage	V_{CC}	-0.3 to +7.0	V	1
All input and output voltage	V_{in}, V_{out}	-0.3 to $V_{CC} + 0.3$	V	1
Operating temperature range	T_{opr}	0 to +70	°C	
Storage temperature range	T_{stg}	-55 to +125	°C	
Temperature under bias	T_{bias}	-20 to +85	°C	

Note: 1. With respect to V_{SS} .

Recommended DC Operating Conditions ($V_{SS} = 0$ V, $T_a = 0$ to +70°C)

Parameter	Symbol	Min	Typ	Max	Unit
Supply voltage	V_{CC}	4.5	5.0	5.5	V
Input voltage	V_{IH}	2.2	—	$V_{CC} + 0.3$	V
	V_{IL}	-0.3	—	0.8	V

DC Characteristics ($V_{CC} = 5$ V \pm 10%, $V_{SS} = 0$ V, $T_a = 0$ to +70°C)

Parameter		Symbol	Min	Max	Unit	Test Conditions
Supply current	Active	I_{CC}	—	80	mA	$V_{CC} = 5.5$ V, $I_{DOUT} = 0$ mA, $t_{RC} = \text{min}$
	Standby	I_{SB}	—	30	μ A	$V_{CC} = 5.5$ V, $\overline{CE} \geq V_{CC} - 0.2$ V
Input leakage current		$ I_{IL} $	—	10	μ A	$V_{in} = 0$ to V_{CC}
Output leakage current		$ I_{OL} $	—	10	μ A	$\overline{CE} = 2.4$ V, $V_{OUT} = 0$ to V_{CC}
Output voltage		V_{OH}	2.4	—	V	$I_{OH} = -205$ μ A
		V_{OL}	—	0.4	V	$I_{OL} = 1.6$ mA

Capacitance ($V_{CC} = 5$ V \pm 10%, $V_{SS} = 0$ V, $T_a = 25$ °C, $V_{IN} = 0$ V, $f = 1$ MHz)

Parameter	Symbol	Min	Max	Unit
Input capacitance	C_{in}	—	15	pF
Output capacitance	C_{out}	—	15	pF

HN62338B Series

AC Characteristics ($V_{CC} = 5\text{ V} \pm 10\%$, $V_{SS} = 0\text{ V}$, $T_a = 0\text{ to }+70^\circ\text{C}$)

- Output load: 1TTL gate + $C_L = 100\text{ pF}$
(including jig capacitance)
- Input pulse level: 0.45 to 2.4 V
- Input and output timing reference levels: 1.5 V
- Input rise and fall time: 5 ns

Parameter	Symbol	HN62338B-15		Unit
		Min	Max	
Read cycle time	t_{RC}	150	—	ns
Address access time	t_{AA}	—	150	ns
\overline{CE} access time	t_{ACE}	—	150	ns
\overline{OE} access time	t_{OE}	—	70	ns
Output hold time from address change	t_{DHA}	0	—	ns
Output hold time from \overline{CE}	t_{DHC}	0	—	ns
Output hold time from \overline{OE}	t_{DHO}	0	—	ns
\overline{CE} to output in high-Z	t_{CHZ}^1	—	70	ns
\overline{OE} to output in high-Z	t_{OHZ}^1	—	70	ns
\overline{CE} to output in low-Z	t_{CLZ}	10	—	ns
\overline{OE} to output in low-Z	t_{OLZ}	10	—	ns

Note: 1. t_{CHZ} and t_{OHZ} are defined as the time at which the output achieves the open circuit conditions and are not referred to output voltage levels.

Timing Waveforms

Word Mode (BHE = 'V_{IH}') or Byte Mode (BHE = 'V_{IL}')

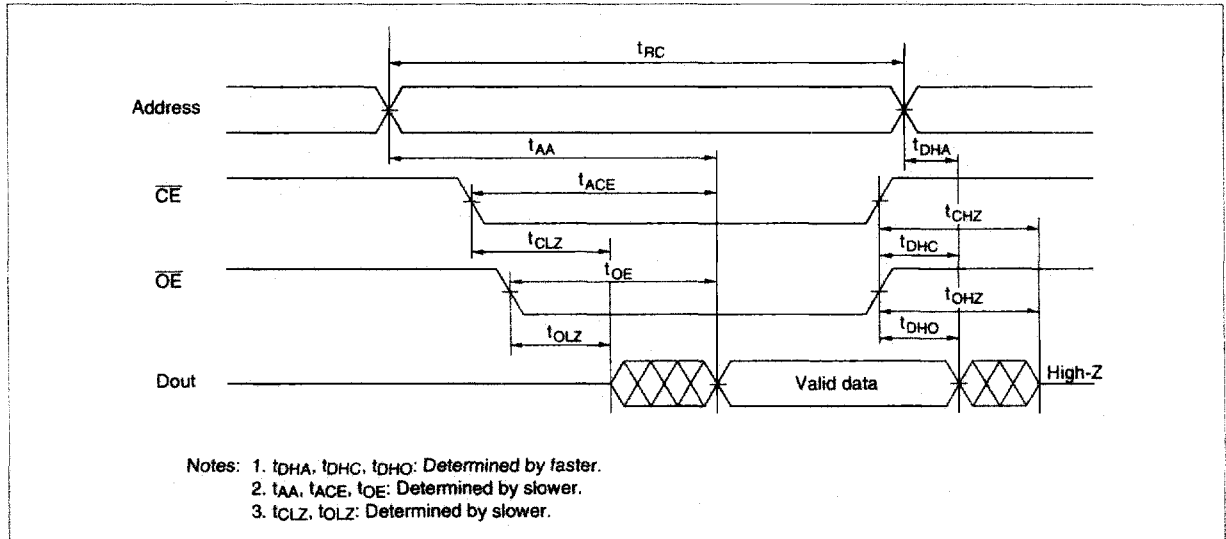

Power Up Sequence

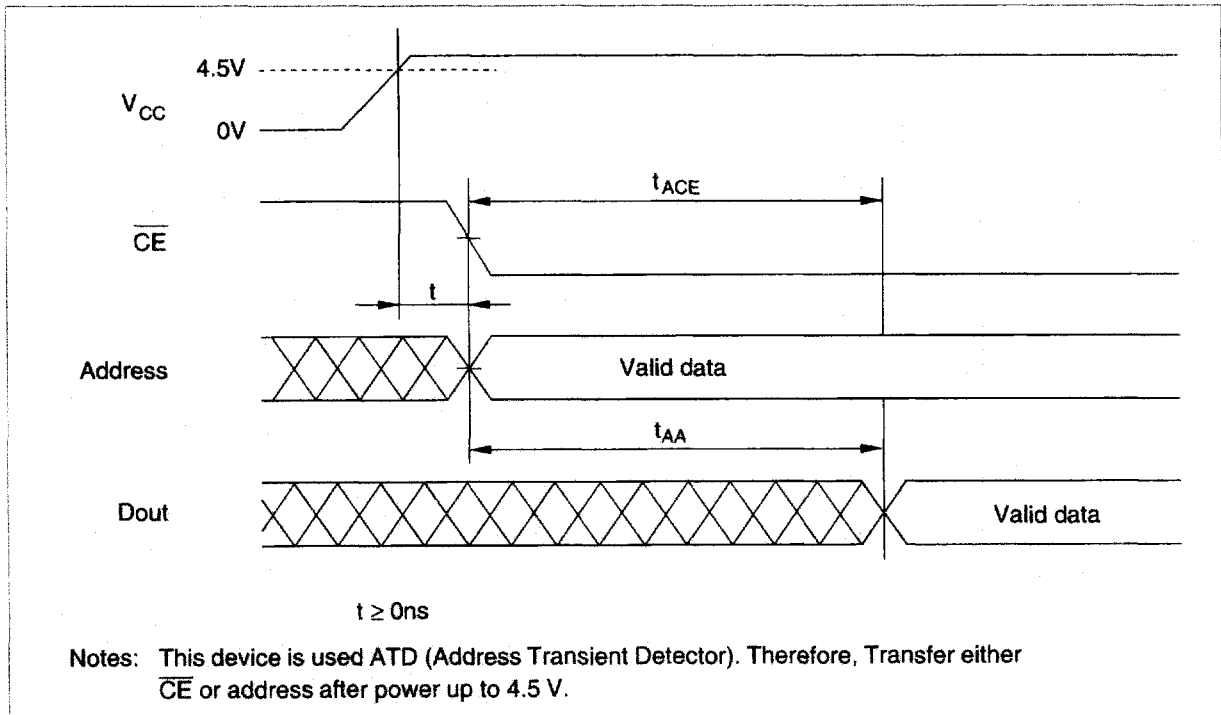

HN62338B Series

Package Dimensions

HM62338BP Series (DP-32)

Unit: mm

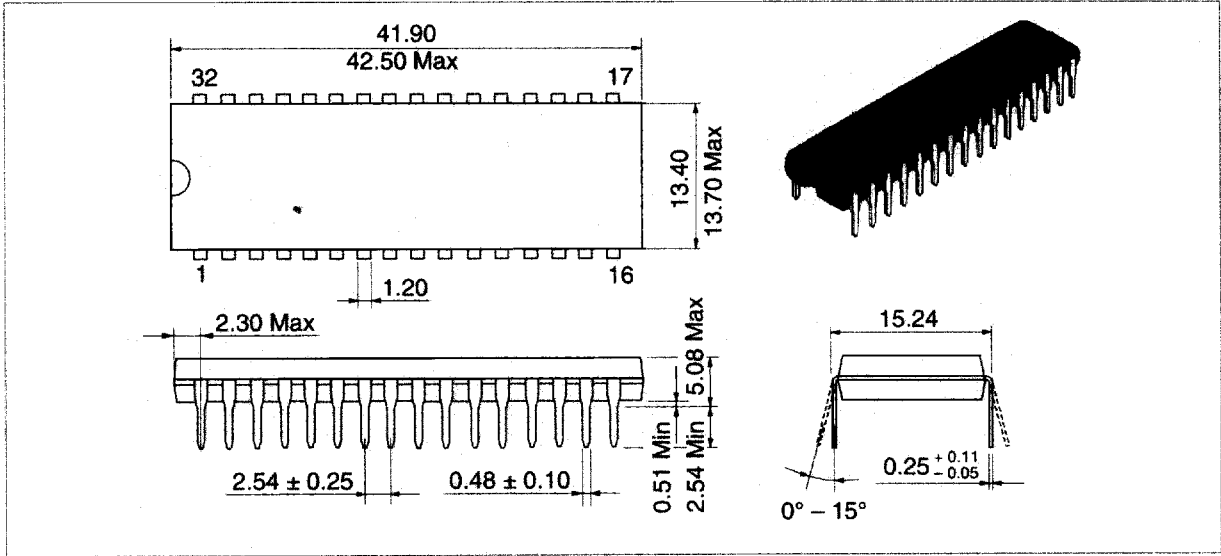

HM62338BF Series (FP-32D)

Unit: mm

