

CLC412

APPLICATIONS:

- HDTV, NTSC & PAL video systems
- video switching and distribution
- IQ amplifiers
- wideband active filters
- cable drivers
- dc coupled single-to-differential conversions

DESCRIPTION

The CLC412 combines a high-speed complementary bipolar process with Comlinear's current-feedback topology to produce a very high-speed dual op amp. The CLC412 provides a 250MHz small-signal bandwidth at a gain of +2V/V and a 1300V/ μ s slew rate while consuming only 50mW per amplifier from \pm 5V supplies.

The CLC412 offers exceptional video performance with its 0.02% and 0.02° differential gain and phase errors for NTSC and PAL video signals while driving one back terminated 75 Ω load. The CLC412 also offers a flat gain response of 0.1dB to 30MHz and very low channel-to-channel crosstalk of -76dB at 10MHz. Additionally, each amplifier can deliver a 70mA continuous output current. This level of performance makes the CLC412 an ideal dual op amp for high-density broadcast-quality video systems.

The CLC412's two very well-matched amplifiers support a number of applications such as differential line drivers and receivers. In addition, the CLC412 is well suited for Sallen Key active filters in applications such as anti-aliasing filters for high-speed A/D converters. Its small 8-pin SOIC package, low power requirement, low noise and distortion allow the CLC412 to serve portable RF applications such as IQ-channels.

The CLC412 is available in the following versions.

CLC412AJP	-40°C to +85°C	8-pin Plastic DIP
CLC412AJE	-40°C to +85°C	8-pin Plastic SOIC
CLC412AIB	-40°C to +85°C	8-pin CERDIP
CLC412A8B	-55°C to +125°C	8-pin CERDIP, MIL-STD-883, Level B
CLC412A8L-2A	-55°C to +125°C	20-pin LCC, MIL-STD-883, Level B
CLC412ALC	-55°C to +125°C	dice
CLC412AMC	-55°C to +125°C	dice, MIL-STD-883, Level B

Contact factory for other packages and DESC SMD number.

FEATURES:

- wide bandwidth 330MHz ($A_v=+1V/V$)
250MHz ($A_v=+2V/V$)
- 0.1dB gain flatness to 30MHz
- low power: 5mA/channel
- very low diff. gain, phase: 0.02%, 0.02°
- -76dB channel-to-channel crosstalk (10MHz)
- fast slew rate: 1300V/ μ s
- unity-gain stable

Channel-to-Channel Crosstalk

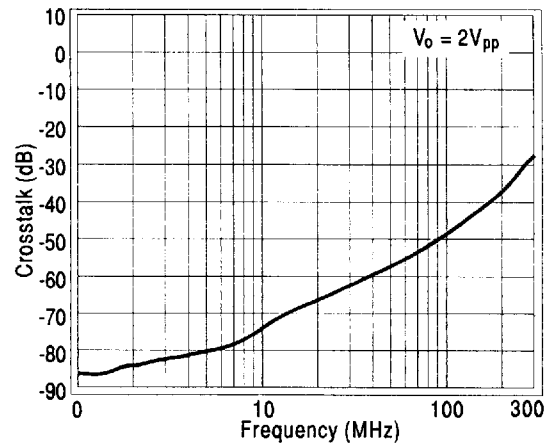

Pinout
DIP & SOIC

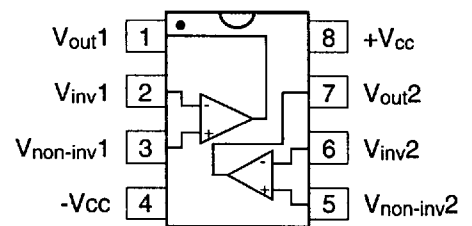

TYPICAL APPLICATION Sallen-Key Low-Pass Filter

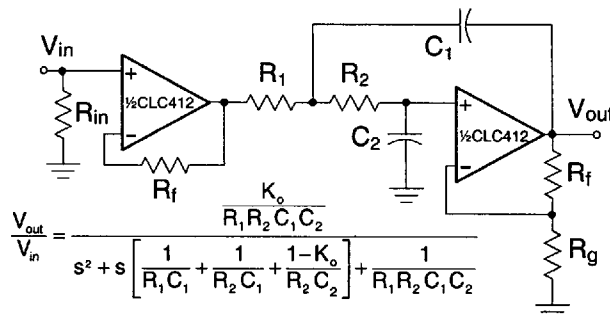

CLC412 Electrical Characteristics ($A_V = +2$; $R_f = 634\Omega$; $V_{CC} = \pm 5V$; $R_L = 100\Omega$)

PARAMETERS		CONDITIONS	TYP	MIN AND MAX RATINGS		UNITS	SYMBOL
Ambient Temperature		CLC412 AJ/AI	+25°C	-40°C	+25°C	+85°C	
Ambient Temperature		CLC412 A8/AM/AL	+25°C	-55°C	+25°C	+125°C	
FREQUENCY DOMAIN RESPONSE							
†-3dB bandwidth		$V_{out} < 0.5V_{pp}$	250	150	175	135	MHz
		$V_{out} < 4.0V_{pp}$	105	80	80	65	MHz
gain flatness		$V_{out} < 0.5V_{pp}$					
†peaking		DC to 30MHz	0.1	0.1	0.1	0.2	dB
†rolloff		DC to 30MHz	0.1	0.4	0.3	0.3	dB
linear phase deviation		DC to 75MHz	0.5	1.3	1.0	1.0	deg
differential gain		4.43MHz, $R_L = 150\Omega$	0.02	0.04	0.04	0.08	%
differential phase		4.43MHz, $R_L = 150\Omega$	0.02	0.04	0.04	0.08	deg
TIME DOMAIN RESPONSE							
rise and fall time		0.5V step	1.4	2.3	2.0	2.6	ns
		4V step	3.2	4.4	4.4	4.8	ns
settling time to 0.05%		2V step	12	18	18	20	ns
overshoot		0.5V step	8	15	15	15	%
slew rate		2V step	1300	1000	1000	800	V/ μ s
DISTORTION AND NOISE RESPONSE							
†2 nd harmonic distortion		2V _{pp} , 20MHz	-46	-42	-42	-38	dBc
†3 rd harmonic distortion		2V _{pp} , 20MHz	-50	-46	-46	-42	dBc
3 rd order intermodulation intercept		10MHz	43				dBm _{1Hz}
equivalent noise input							
non-inverting voltage		>1MHz	3.0	3.4	3.4	3.8	nV/ \sqrt Hz
inverting current		>1MHz	12.0	13.9	13.9	15.5	pA/ \sqrt Hz
non-inverting current		>1MHz	2.0	2.6	2.6	3.0	pA/ \sqrt Hz
noise floor		>1MHz	-157	-156	-156	-155	dBm _{1Hz}
crosstalk input-referred		10MHz (note 1)	-76	-70	-70	-70	dB
input-referred		10MHz (note 2)	-70	-64	-64	-64	dB
STATIC DC PERFORMANCE							
*input offset voltage			±2	±10	±6	±12	mV
average drift			±30	±60	—	±60	μ V/°C
*input bias current		non-inverting	±5	±28	±12	±12	μ A
average drift			±30	±187	—	±90	nA/°C
*input bias current		inverting	±3	±34	±15	±20	μ A
average drift			±20	±125	—	±80	nA/°C
†power supply rejection ratio		DC	50	46	46	44	dB
▲common mode rejection ratio		DC	50	45	45	43	dB
*supply current		$R_L = \infty$	10.2	13.6	12.8	12.8	mA
MISCELLANEOUS PERFORMANCE							
input resistance		non-inverting	1000	300	500	500	k Ω
input capacitance		non-inverting	1.0	2.0	2.0	2.0	pF
output resistance		closed loop	0.04	0.6	0.3	0.2	Ω
output voltage range		$R_L = \infty$	+3.8,-3.3	+3.6,-2.9	+3.7,-3.0	+3.7,-3.0	V
		$R_L = 100\Omega$	+3.1,-2.9	+2.0,-2.5	±2.7	±2.7	V
		$R_L = 100\Omega$ (0° to 70°C)			+2.5,-2.6		V
input voltage range		common mode	±2.2	±1.4	±2.0	±2.0	V
output current			70	25	45	45	mA

Absolute Maximum Ratings

Miscellaneous Ratings

V_{CC}	±7V
I_{out} short circuit protected to ground, however maximum reliability is obtained if I_{out} does not exceed...	150mA
common-mode input voltage	± V_{CC}
maximum junction temperature	+175°C
operating temperature range	
AJ/AI	-40°C to +85°C
AB/AM/AL:	-55°C to +125°C
storage temperature range	-65°C to +150°C
lead temperature (soldering 10 sec)	+300°C

Recommended gain range ±1 to ±10V/V

Notes:

- * AJ, AI : 100% tested at +25°C, sample tested at +85°C.
- † AJ : Sample tested at +25°C.
- † AI : 100% tested at +25°C.
- * A8 : 100% tested at +25°C, -55°C, +125°C.
- † A8 : 100% tested at +25°C, sample at -55°C, +125°C
- * AL, AM : 100% wafer probed +25°C to +25°C min/max specs.
- ▲ SMD : Sample tested at +25°C, -55°C, +125°C.
- note 1) : Specification is guaranteed for AJ, AL, AM only.
- note 2) : Specification guaranteed for A8, AI only.

Comlinear reserves the right to change specifications without notice.

CLC412 Typical Performance ($T_A=25^\circ\text{C}$, $V_{CC}=\pm 5\text{V}$, $A_V=\pm 2\text{V/V}$, $R_f=634\Omega$, $R_L=100\Omega$, unless noted)

Non-Inverting Frequency Response

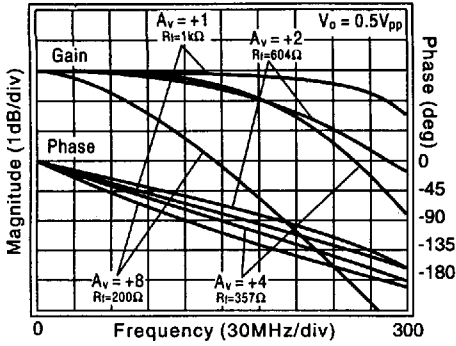

Inverting Frequency Response

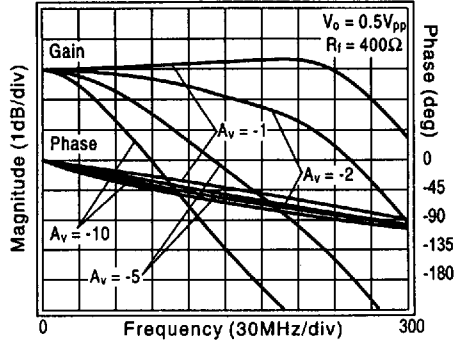

Frequency Response vs. V_{out}

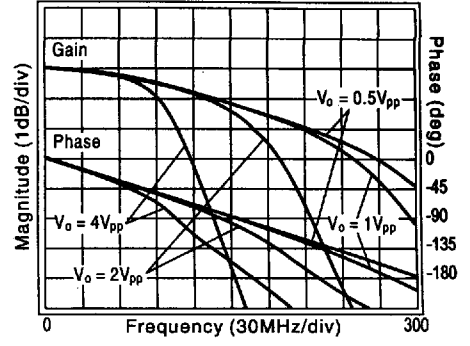

Small Signal Channel Matching

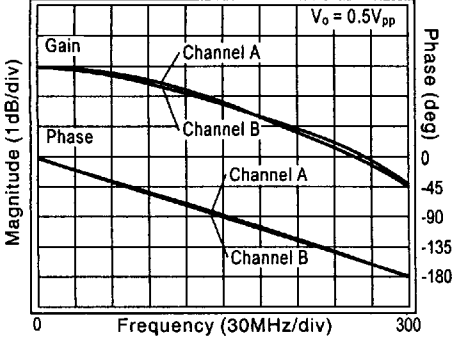

Gain Flatness for Various Gains

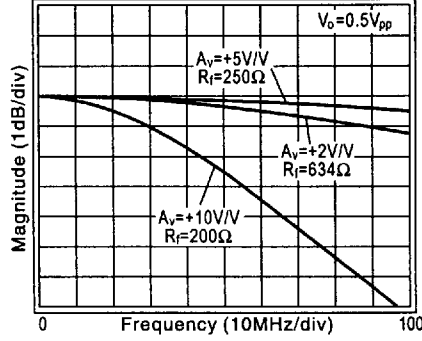

Frequency Response vs. Load (R_L)

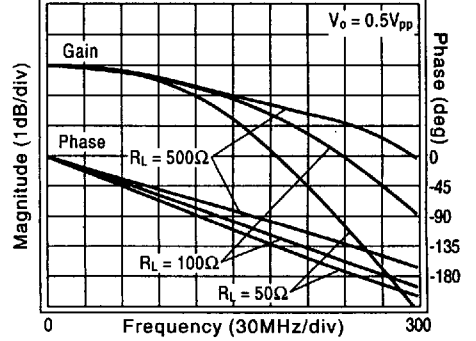

Pulse Response

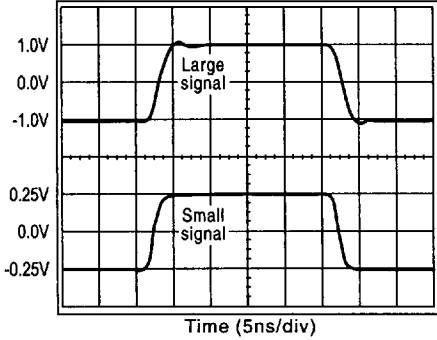

Pulse Crosstalk

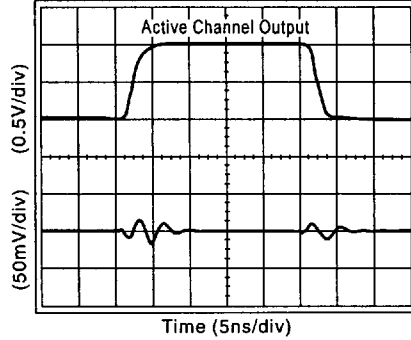

Phase Linearity

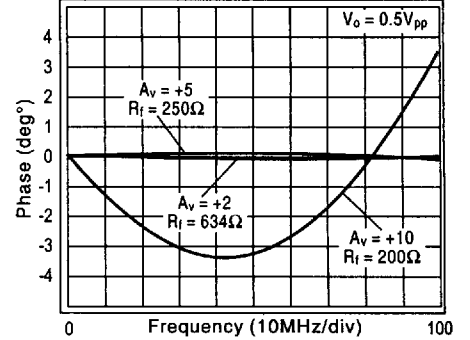

Input-Referred Crosstalk

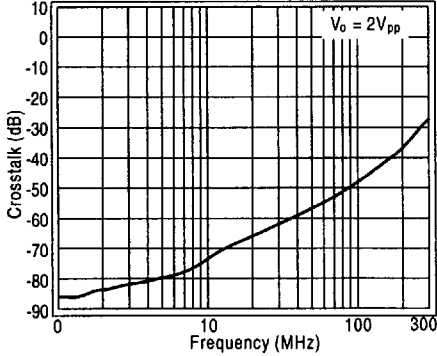

Short-Term Settling Time

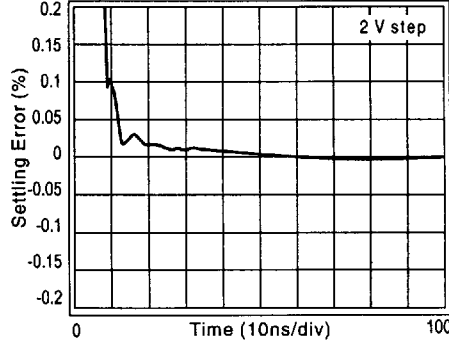

Long Term Settling Time

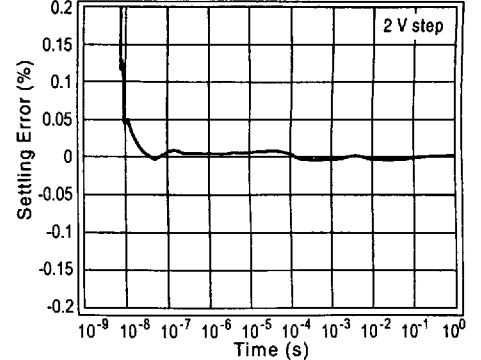

R_s and Settling Time vs. Capacitive Load

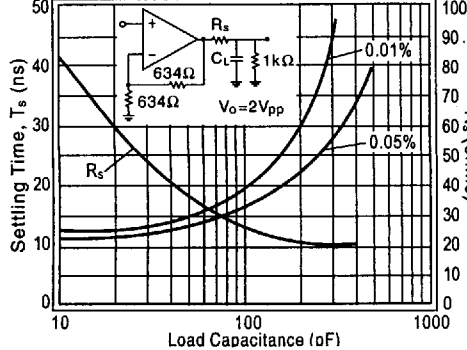

Maximum Output Swing vs. Frequency

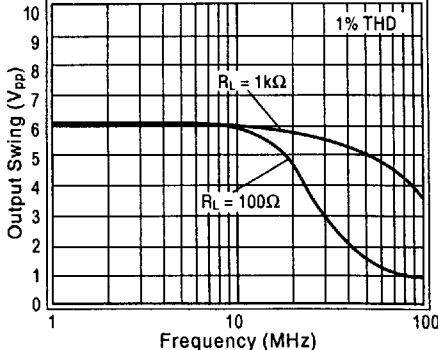

-3dB Bandwidth vs. Output Voltage

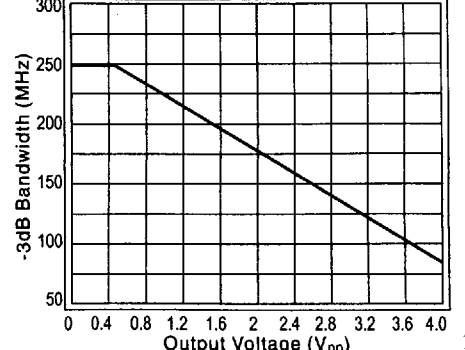

CLC412 Typical Performance ($T_A=25^\circ\text{C}$, $V_{CC}=5\text{V}$, $A_V=\pm 2\text{V/V}$, $R_I=634\Omega$, $R_L=100\Omega$, unless noted)

Typical DC Errors vs. Temperature

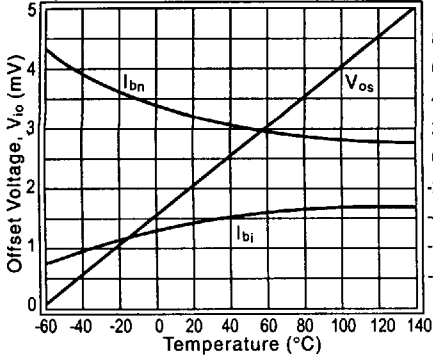

Typical DC Error Mismatch vs. Temp

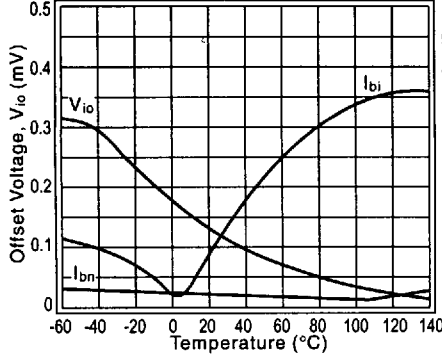

Open-Loop Transimpedance, Z(s)

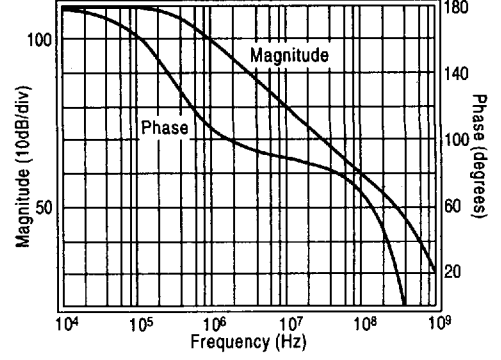

Equivalent Input Noise

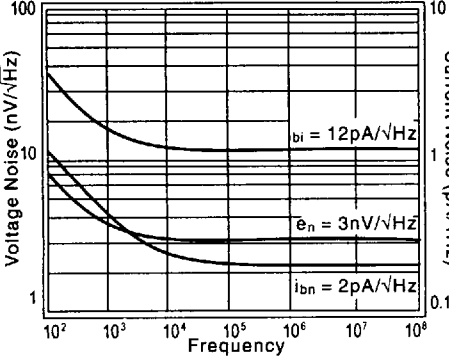

Total Input-Referred Noise vs. Gain

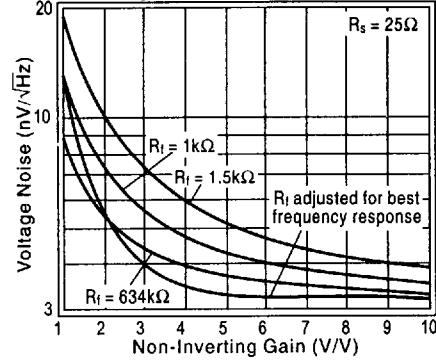

Differential Gain vs. Frequency

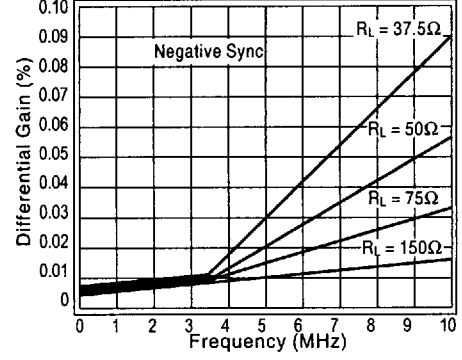

2nd Harmonic Distortion

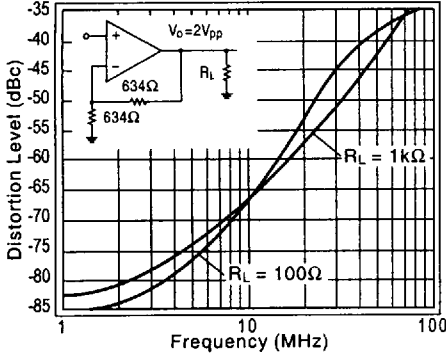

Group Delay Variation

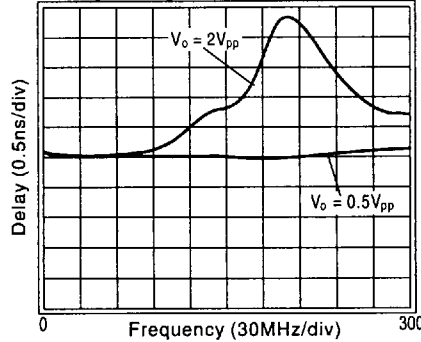

Differential Phase vs. Frequency

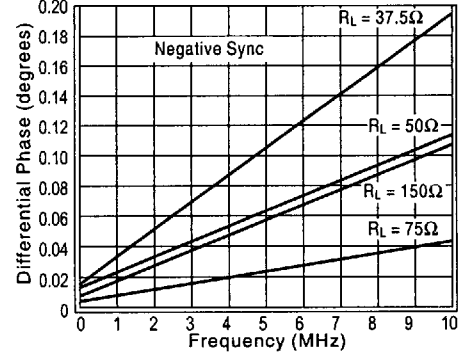

3rd Harmonic Distortion

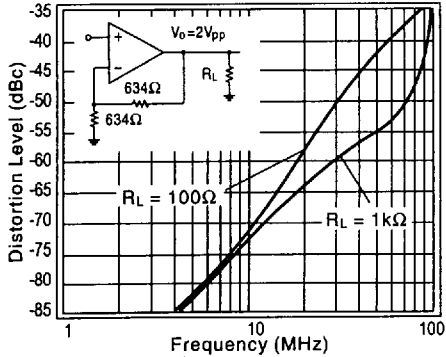

2nd Harmonic Distortion vs. P_out

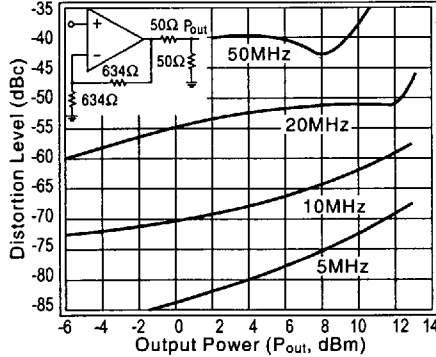

PSRR, CMRR and Closed Loop R_o

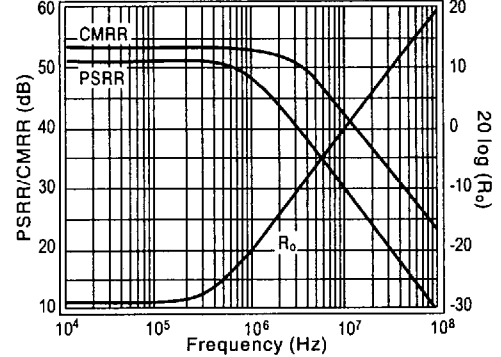

2-Tone, 3rd Order Intermod Intercept

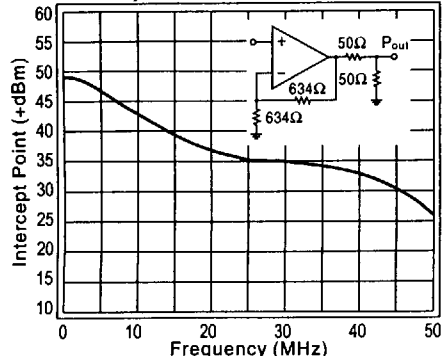

3rd Harmonic Distortion vs. P_out

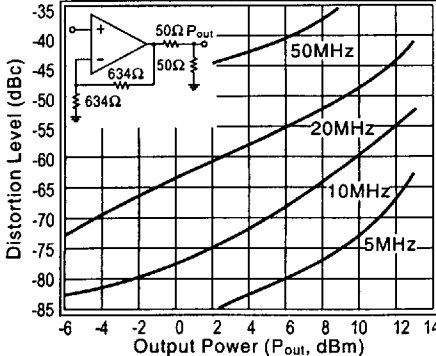

-3dB Bandwidth Variation Over Process

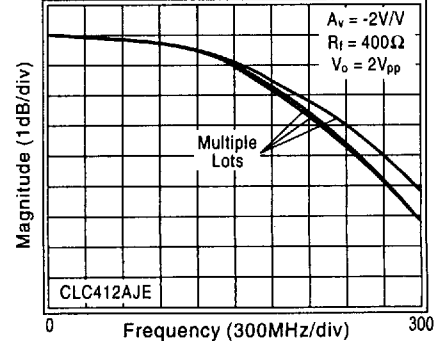

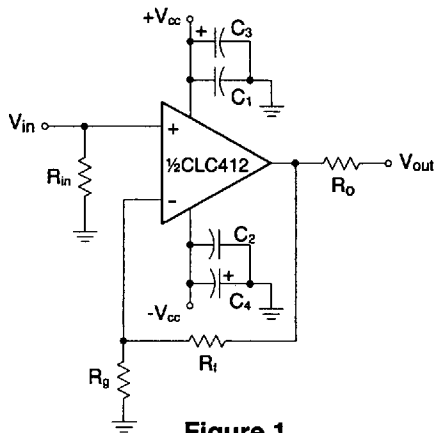

Figure 1

Application Introduction

Offered in an 8-pin package for reduced space and cost, the wideband CLC412 dual current-feedback op amp provides closely matched DC & AC electrical performance characteristics making the part an ideal choice for wideband signal processing. Applications such as broadcast-quality video systems, IQ amplifiers, filter blocks, high-speed peak detectors, integrators and transimpedance amplifiers will all find superior performance in the CLC412 dual op amp.

Feedback Resistor Selection

The loop gain and frequency response for a current-feedback operational amplifier is determined largely by the feedback resistor, R_f . The Electrical Characteristics and Typical Performance plots specify an R_f of 634Ω , a gain of $+2V/V$ and operation with $\pm 5V$ power supplies (unless otherwise stated). Generally, lowering R_f from its recommended value will peak the frequency response and extend the bandwidth while increasing its value will roll off the response. Reducing the value of R_f too far below its recommended value will cause overshoot, ringing and eventually oscillation.

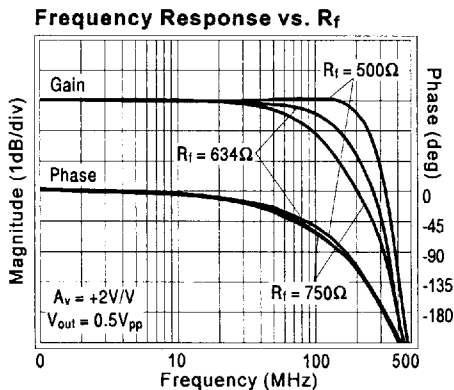

The plot above labeled "Frequency Response vs. R_f " shows the CLC412's frequency and phase response as R_f is varied while the gain remains constant at $+2V/V$ ($R_L=100\Omega$). This plot shows that one particular value of R_f will optimize the frequency and phase response at the specified gain setting, i.e. 634Ω at a gain of $+2V/V$. Current-feedback op amps, unlike voltage-feedback op amps, have a direct relationship between their frequency

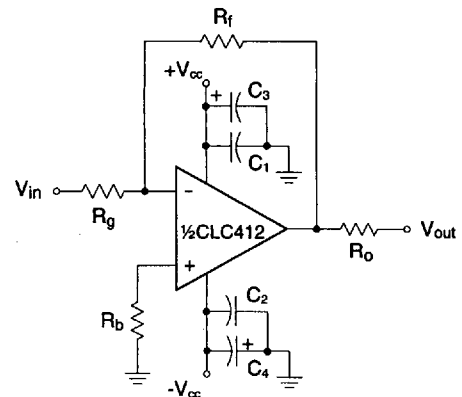
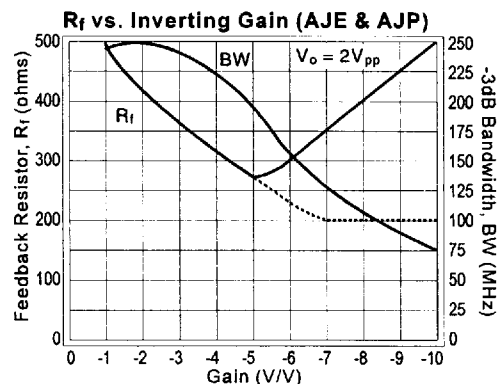
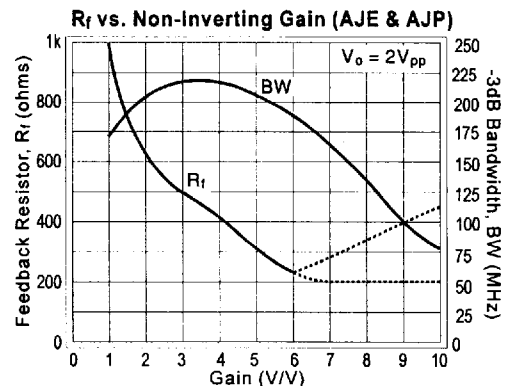

Figure 2

and phase response to the value of the feedback resistor, R_f . For more information see Application Note OA-13 which describes the relationship between R_f and closed-loop frequency response.

When configuring the CLC412 for other inverting or non-inverting gains, it is necessary to adjust the value of the feedback resistor in order to optimize the device's frequency and phase response. The two plots below provide the means of selecting the recommended feedback-resistor value for both inverting and non-



inverting gain selections. Both plots show the value of R_f approaching a non-zero minimum (dashed line) at high gains, which is characteristic of current-feedback op amps, while the linear portion of the two (solid) curves (i.e. $-5 > A_v > +6$) results from the limitation placed on R_g (i.e. $R_g \geq 50\Omega$). This limitation is due to the desire to keep R_g greater in value than that of the inverting input resistance. Therefore, the resulting small-signal

bandwidth curves, labeled "BW", correspond to the two (solid) "R_f" curves. These results may deviate from that produced by the analysis of OA-13 since these plots were produced from an actual board layout that included parasitic capacitances not accounted for by the analysis of OA-13. It should be noted that a non-inverting gain of +1V/V requires an R_f = 1kΩ and the output voltage used for both plots is 2V_{pp}.

In order to bandlimit the CLC412 at any particular gain setting, a larger value of R_f (than previously recommended in the plots above) is needed. Following the analysis in OA-13, we find the CLC412's "optimum feedback transimpedance", Z_t^{*}, below.

$$\begin{aligned} Z_t^* &= R_f + R_{in} \left(1 + \frac{R_f}{R_g} \right) \\ &= 634 + 60 \left(1 + \frac{634}{634} \right) \\ &= 754\Omega \\ 20\log(754) &= 57.5\text{dB} \end{aligned}$$

The "optimum feedback transimpedance" is unique for each current-feedback op amp and determines the recommended value of R_f for a particular gain setting. Drawing a horizontal line on the "Open-loop Transimpedance, Z(s)" plot from 57.5dB (on the left vertical axis), we find the intersection with the transimpedance magnitude trace occurs at a frequency of 180MHz. This frequency is *only an approximation* of the CLC412's small-signal bandwidth. From this intersection, one can see that an increase in Z_t will produce a new intersection occurring at a lower frequency. This is the process to follow when bandlimiting. Once the target small-signal bandwidth is determined, the new value of Z_t is picked off the graph at the point where the this frequency and the transimpedance magnitude trace intersect. One can then back track to figure the value of the feedback resistor, R_f = Z_t - R_{in}(1 + R_f/R_g). This new value of R_f will produce the desired frequency roll-off.

Circuit Layout

With all high-frequency devices, board layouts with stray capacitances have a strong influence over AC performance. The CLC412 is no exception and its input and output pins are particularly sensitive to the coupling of parasitic capacitances (to ac ground) arising from traces or pads placed too closely (<0.1") to power or ground planes. In some cases, due to the frequency response peaking caused by these parasitics, a small adjustment of the feedback resistor value will serve to compensate the frequency response. Also, it is very important to keep the parasitic capacitance across the feedback resistor to an absolute minimum.

The performance plots in the data sheet can be reproduced using the evaluation boards available from Comlinear. There are two types of boards; the DIP (#730038) and SOIC (#730036). The #730036 board uses all SMT parts for the evaluation of the CLC412 in its surface mount package. Either of these layouts can

assist the designer in obtaining the desired performance. In addition, the boards can serve as an example layout for the final production printed circuit board.

Care must also be taken with the CLC412's layout in order to achieve the best circuit performance, particularly channel-to-channel isolation. The decoupling capacitors (both tantalum and ceramic) must be chosen with good high frequency characteristics to decouple the power supplies and the physical placement of the CLC412's external components is critical. Grouping each amplifier's external components with their own ground connection and separating them from the external components of the opposing channel with the maximum possible distance is recommended. The input (R_{in}) and gain-setting resistors (R_g) are the most critical. It is also recommended that the ceramic decoupling capacitor (0.1μF chip or radial-leaded with low ESR) should be placed as closely to the power pins as possible.

Package Parasitics

In addition to the parasitic capacitances arising from the board layout, each of the CLC412's packages has its own characteristic set of parasitic capacitances and inductances causing frequency response variation from package to package as shown in the plot below labeled "Frequency Response vs. Package Type". Due to its much smaller size, the CLC412AJE (8-pin SOIC) shows the least amount of peaking.

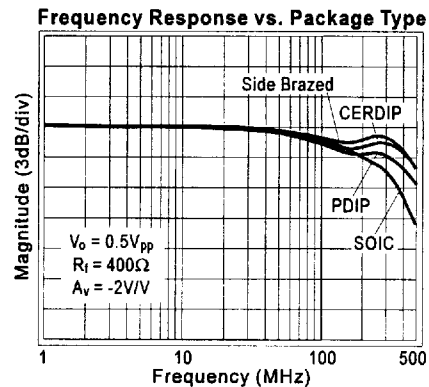

Matching Performance

With proper board layout, the AC performance match between the two CLC412's amplifiers can be tightly

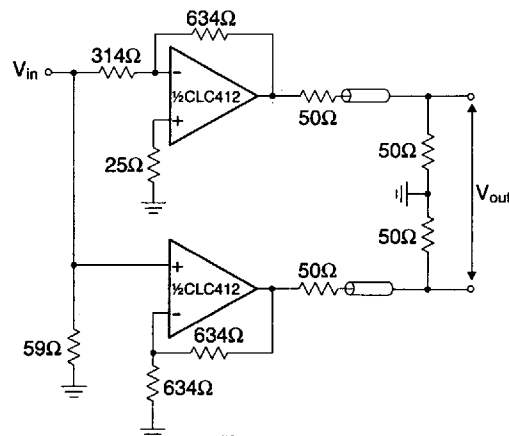
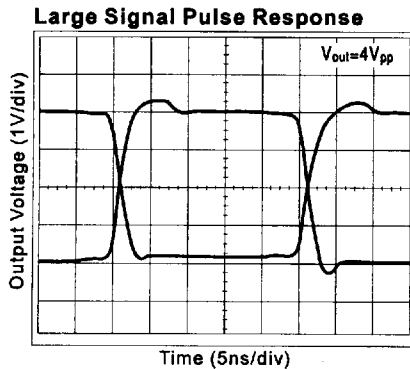

Figure 3

controlled as shown in Typical Performance plot labeled "Small-Signal Channel Matching". The measurements were performed with SMT components using the recommended value of feedback resistor of 634Ω at a gain of +2V/V. The pulse response plot labeled "Pulse Matching" found below shows the group delay matching between amplifiers of the CLC412. The circuit topology is described in Figure 3.



The CLC412's amplifiers, built on the same die, provide the advantage of having tightly matched DC characteristics. The typical DC matching specifications of the CLC412 are:

$$\Delta V_{io} = \pm 0.60\text{mV}, \Delta I_{bn} = \pm 0.25\mu\text{A}, \Delta I_{bi} = \pm 1.5\mu\text{A}.$$

Slew Rate and Settling Time

One of the advantages of current-feedback topology is an inherently high slew rate which produces a wider full-power bandwidth. The CLC412 has a typical slew rate of 1300V/μs. The required slew rate for a design can be calculated by the following equation: $SR = 2\pi f V_{pk}$

Careful attention to parasitic capacitances is critical to achieving the best settling time performance. The CLC412 has a typical short term settling time to 0.05% of 12ns for a 2 volt step. Also, the amplifier is virtually free of any long term thermal tail effects at low gains as shown in the Typical Performance plot labeled "Long Term Settling Time".

When measuring settling time, a solid ground plane should be used in order to reduce ground inductance which can cause common-ground-impedance coupling. Power supply and ground trace parasitic capacitances and the load capacitance will also affect settling time.

Placing a series resistor (R_s) at the output pin is recommended for optimal settling time performance when driving a capacitive load. The Typical Performance plot labeled " R_s and Settling Time vs. Capacitive Load" provides a means for selecting a value of R_s for a given capacitive load. The plot also shows the resulting settling time to 0.05 and 0.01%.

DC & Noise Performance

A current-feedback amplifier's input stage does not have equal nor correlated bias currents, therefore they cannot

be canceled and each contributes to the total DC offset voltage at the output by the following equation:

$$V_{\text{offset}} = \pm \left(I_{bn} * R_s \left(1 + \frac{R_f}{R_g} \right) + V_{io} \left(1 + \frac{R_f}{R_g} \right) + I_{bi} * R_f \right)$$

The input resistor R_{in} is the resistance looking from the non-inverting input back towards the source. For inverting DC-offset calculations, the source resistance seen by the input resistor R_g must be included in the output offset calculation as a part of the non-inverting gain equation. Application note OA-7 gives several circuits for DC offset correction. The noise currents for the inverting and non-inverting inputs are graphed in the Typical Performance plot labeled "Equivalent Input Noise". A more complete discussion of amplifier input-referred noise and external resistor noise contribution can be found in OA-12.

Differential Gain & Phase

The CLC412 can drive multiple video loads with very low differential gain and phase errors. The Typical Performance plots labeled "Differential Gain vs. Frequency" and "Differential Phase vs. Frequency" show performance for loads from 1 to 4. The Electrical Characteristics table also specifies guaranteed performance for one 150Ω load at 4.43MHz. For NTSC video, the guaranteed performance specifications also apply. Application note OA-08, "Differential Gain and Phase for Composite Video Systems," describes in detail the techniques used to measure differential gain and phase.

I/O Voltage & Output Current

The usable common-mode input voltage range (CMIR) of the CLC412 specified in the Electrical Characteristics table of the data sheet shows a range of ±2.2 volts. Exceeding this range will cause the input stage to saturate and clip the output signal.

The output voltage range is determined by the load resistor and the choice of power supplies. With ±5 volts the class A/B output driver will typically drive +3.1/-2.7 volts into a load resistance of 100Ω. Increasing the supply voltages will change the common-mode input and output voltage swings while at the same time increase the internal junction temperature. The output voltage for different load resistors can be determined from the data sheet plots labeled "Frequency Response vs. Load (R_L)" and "Maximum Output Swing vs. Frequency".

Applications Circuits

Single-to-Differential Line Driver.

The CLC412's well matched AC channel-response allows a single-ended input to be transformed to highly-matched push-pull driver. From a 1V single-ended input the circuit of Figure 4 produces 1V differential signal between the two outputs. For larger signals, the input voltage divider ($R_1 = 2R_2$) is necessary to limit the input voltage on channel 2. To achieve the same performance when driving a matched load, see Figure 3.



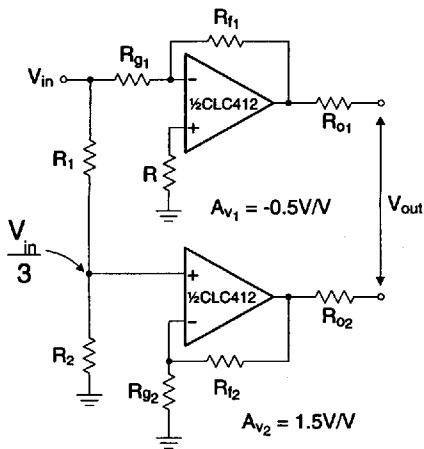

Figure 4

Differential Line Receiver. Figures 5 and 5a show two different implementations of an instrumentation amplifier which convert differential signals to single-ended. Figure 5a allows CMRR adjustment through R_2 .

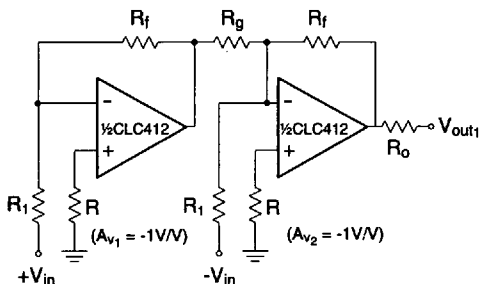

Figure 5

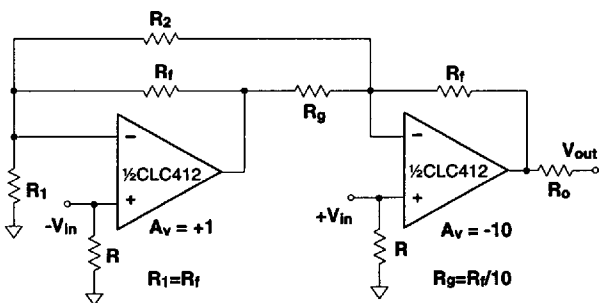

Figure 5a

High-Speed Instrumentation Amplifier.

For applications requiring higher CMRR the composite circuit of Figure 6 uses the two amplifiers of the CLC412 to create balanced inputs for the CLC420 voltage-feedback op amp. The DC CMRR can be fine tuned

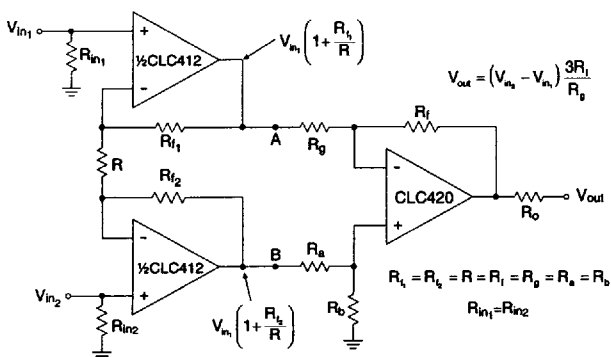

Figure 6

through the adjustment of R_b . Further improvement of CMRR over frequency can be achieved through the placement of an RC network between the outputs (A and B) of the two amplifiers of the CLC412.

Non-Inverting Current-Feedback Integrator.

The circuit of Figure 7 achieves its high-speed integration by placing one of the CLC412's amplifiers in the feedback loop of the second amplifier configured as shown.

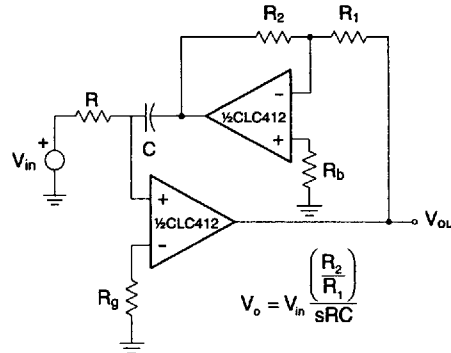

Figure 7

Low-Noise Wide-Bandwidth Transimpedance Amplifier.

Figure 8 implements a low-noise transimpedance amplifier using both channels of the CLC412. This circuit takes advantage of the lower input-bias-current noise of the non-inverting input and achieves negative feedback through the second CLC412 channel. The output voltage is set by the value of R_f while frequency compensation is achieved through the adjustment of R_T .

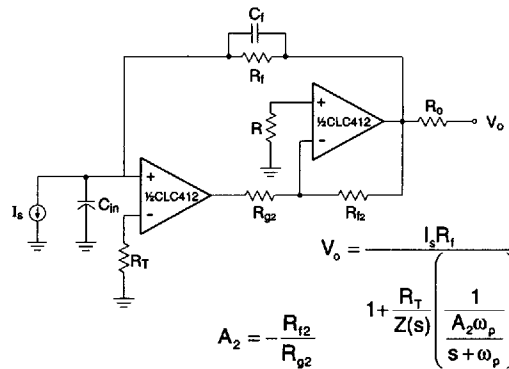

Figure 8

Buffered 2nd-Order Sallen-Key Low-Pass Filter.

Figure 9 shows one implementation of a 2nd order Sallen-Key low pass filter buffered by one of the CLC412's channels. The CLC412 enables greater precision since it provides the advantage of very low output impedance and very linear phase throughout the pass-band.

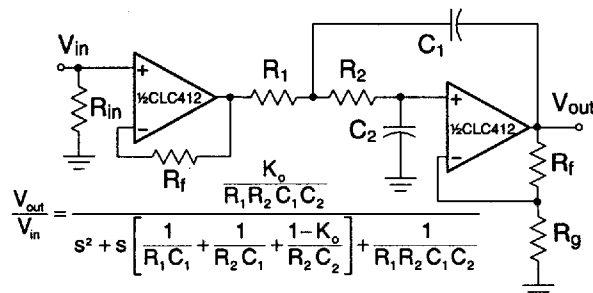

Figure 9