

54ACT11651, 74ACT11651 OCTAL BUS TRANSCEIVERS AND REGISTERS

D3445, MARCH 1990—REVISED OCTOBER 1990

- Inputs are TTL-Voltage Compatible
- Bus Transceivers/Registers
- Independent Registers and Enables for A and B Buses
- Multiplexed Real-Time and Stored Data
- Inverting Data Paths
- Flow-Through Architecture Optimizes PCB Layout
- Center-Pin V_{CC} and GND Configurations Minimize High-Speed Switching Noise
- EPIC™ (Enhanced-Performance Implanted CMOS) 1- μ m Process
- 500-mA Typical Latch-Up Immunity at 125°C
- Package Options Include Plastic "Small Outline" Packages, Ceramic Chip Carriers, and Standard Plastic and Ceramic 300-mil DIPs

description

These devices consist of bus transceiver circuits, D-type flip-flops, and control circuitry arranged for multiplexed transmission of data directly from the data bus or from the internal storage registers. Enables GAB and \bar{G} BA are provided to control the transceiver functions. SAB and SBA control pins are provided to select whether real-time or stored data is transferred. The circuitry used for select control eliminates the typical decoding glitch that occurs in a multiplexer during the transition between stored and real-time data.

A low input level selects real-time data and a high selects stored data. Figure 1 illustrates the four fundamental bus-management functions that can be performed with the octal bus transceivers and registers. Data on the A or B bus, or both, can be stored in the internal D flip-flops by low-to-high transitions at the appropriate clock pins (CAB or CBA) regardless of the select or enable control pins. When SAB and SBA are in the real-time transfer mode, it is also possible to store data without using the internal D-type flip-flops by simultaneously enabling GAB and \bar{G} BA. In this configuration, each output reinforces its input. Thus, when all other data sources to the two sets of bus lines are at high impedance, each set of bus lines remains at its last state.

The 54ACT11651 is characterized for operation over the full military temperature range of -55°C to 125°C. The 74ACT11651 is characterized for operation from -40°C to 85°C.

54ACT11651 . . . JT PACKAGE
74ACT11651 . . . DW OR NT PACKAGE
(TOP VIEW)

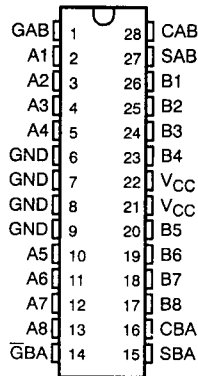

54ACT11651 . . . FK PACKAGE
(TOP VIEW)

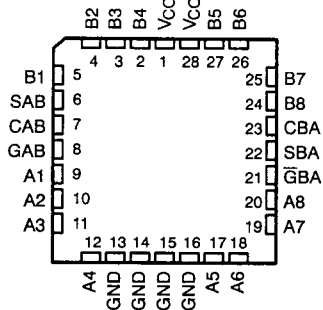

EPIC is a trademark of Texas Instruments Incorporated.

UNLESS OTHERWISE NOTED this document contains PRODUCTION DATA information current as of publication date. Products conform to specifications per the terms of Texas Instruments standard warranty. Production processing does not necessarily include testing of all parameters.



POST OFFICE BOX 655303 • DALLAS, TEXAS 75265

Copyright © 1990, Texas Instruments Incorporated

2-35

54ACT11651, 74ACT11651 OCTAL BUS TRANSCEIVERS AND REGISTERS

D3445, MARCH 1990—REVISED OCTOBER 1990

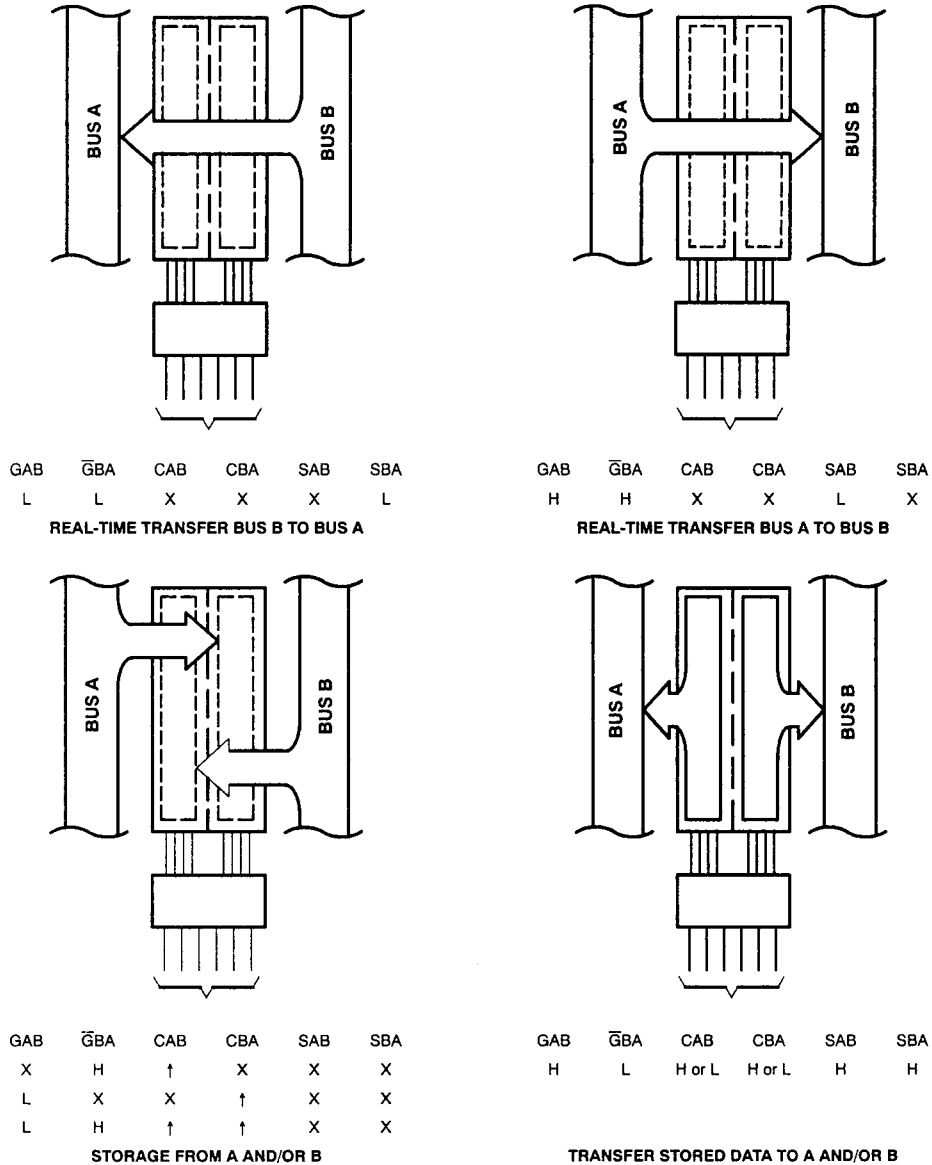

Figure 1. Bus Transfer Diagram

54ACT11651, 74ACT11651 OCTAL BUS TRANSCEIVERS AND REGISTERS

D3445, MARCH 1990—REVISED OCTOBER 1990

FUNCTION TABLE

INPUTS						DATA I/O		OPERATION OR FUNCTION
GAB	$\overline{\text{GBA}}$	CAB	CBA	SAB	SBA	A1 THRU A8	B1 THRU B8	
L	H	H or L	H or L	X	X	Input	Input	Isolation
L	H	↑	↑	X	X	Input	Input	Store A and B Data
X	H	↑	H or L	X	X	Input	Unspecified†	Store A, Hold B
H	H	↑	↑	X‡	X	Input	Output	Store A in both registers
L	X	H or L	↑	X	X	Unspecified†	Input	Hold A, Store B
L	L	↑	↑	X	X‡	Output	Input	Store B in both registers
L	L	X	X	X	L	Output	Input	Real-Time $\overline{\text{B}}$ data to A Bus
L	L	X	H or L	X	H	Output	Input	Stored $\overline{\text{B}}$ Data to A Bus
H	H	X	X	L	X	Input	Output	Real-Time $\overline{\text{A}}$ Data to B Bus
H	H	H or L	X	H	X	Input	Output	Stored $\overline{\text{A}}$ Data to B Bus
H	L	H or L	H or L	H	H	Output	Output	Stored $\overline{\text{A}}$ Data to B Bus and Stored $\overline{\text{B}}$ Data to A Bus

† The data output functions may be enabled or disabled by various signals at the GAB or $\overline{\text{GBA}}$ inputs. Data input functions are always enabled, i.e., data at the bus pins will be stored on every low-to-high transition on the clock inputs.

‡ Select control = L: clocks can occur simultaneously. Select control = H: clocks must be staggered in order to load both registers.

logic symbols§

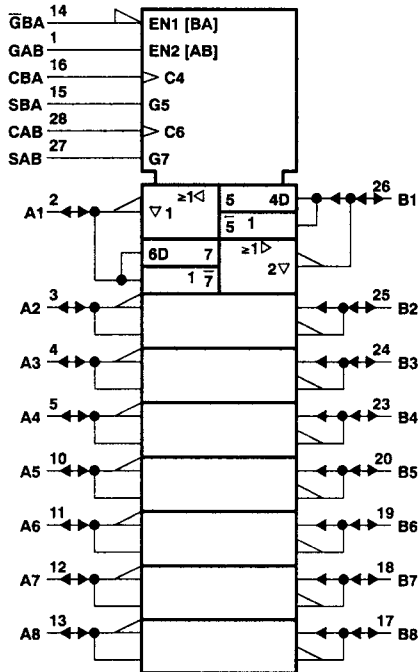

§ This symbol is in accordance with ANSI/IEEE Std 91-1984 and IEC Publication 617-12. Pin numbers shown are for DW, JT, and NT packages.



POST OFFICE BOX 655303 • DALLAS, TEXAS 75265

54ACT11651, 74ACT11651 OCTAL BUS TRANSCEIVERS AND REGISTERS

D3445, MARCH 1990—REVISED OCTOBER 1990

logic diagram (positive logic)

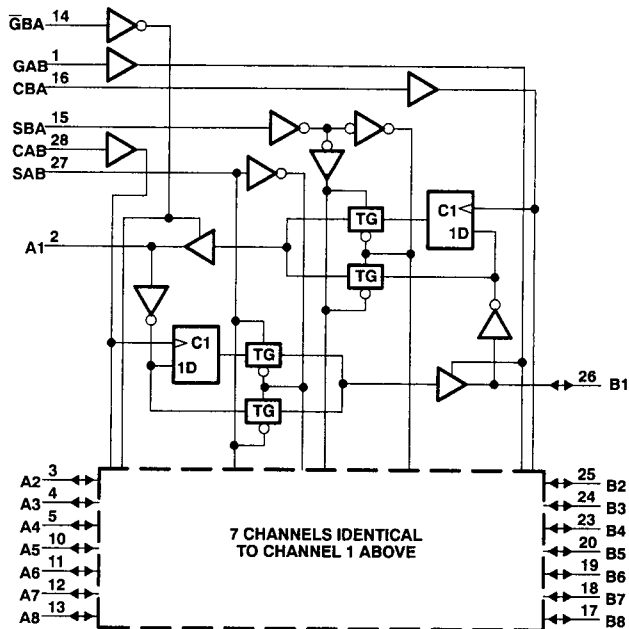

Pin numbers shown are for DW, JT, or NT packages.

absolute maximum ratings over operating free-air temperature range (unless otherwise noted)[†]

Supply voltage range, V_{CC}	-0.5 V to 7 V
Input voltage range, V_I (see Note 1)	-0.5 V to $V_{CC} + 0.5$ V
Output voltage range, V_O (see Note 1)	-0.5 V to $V_{CC} + 0.5$ V
Input clamp current, I_{IK} ($V_I < 0$ or $V_I > V_{CC}$)	± 20 mA
Output clamp current, I_{OK} ($V_O < 0$ or $V_O > V_{CC}$)	± 50 mA
Continuous output current, I_O ($V_O = 0$ to V_{CC})	± 50 mA
Continuous current through V_{CC} or GND pins	± 200 mA
Storage temperature range	-65°C to 150°C

[†] Stresses beyond those listed under "absolute maximum ratings" may cause permanent damage to the device. These are stress ratings only and functional operation of the device at these or any other conditions beyond those indicated under "recommended operating conditions" is not implied. Exposure to absolute-maximum-rated conditions for extended periods may affect device reliability.

NOTE 1: The input and output voltage ratings may be exceeded if the input and output current ratings are observed.

TEXAS
INSTRUMENTS

54ACT11651, 74ACT11651 OCTAL BUS TRANSCEIVERS AND REGISTERS

D3445, MARCH 1990—REVISED OCTOBER 1990

recommended operating conditions

		SN54ACT11651			SN74ACT11651			UNIT
		MIN	NOM	MAX	MIN	NOM	MAX	
V _{CC}	Supply voltage	4.5	5	5.5	4.5	5	5.5	V
V _{IH}	High-level input voltage	2			2			V
V _{IL}	Low-level input voltage				0.8			V
V _I	Input voltage	0			V _{CC}			V
V _O	Output voltage	0			V _{CC}			V
I _{OH}	High-level output current				-24			mA
I _{OL}	Low-level output current				24			mA
Δt/Δv	Input transition rise or fall rate	0			10			ns/V
T _A	Operating free-air temperature	-55			125			°C

electrical characteristics over recommended operating free-air temperature range (unless otherwise noted)

PARAMETER	TEST CONDITIONS	V _{CC}	T _A = 25°C			54ACT11651		74ACT11651		UNIT
			MIN	TYP	MAX	MIN	MAX	MIN	MAX	
V _{OH}	I _{OH} = -50 μA	4.5 V	4.4			4.4		4.4		V
		5.5 V	5.4			5.4		5.4		
	I _{OH} = -24 mA	4.5 V	3.94			3.7		3.8		
		5.5 V	4.94			4.7		4.8		
	I _{OH} = -50 mA†	5.5 V				3.85				
I _{OH} = -75 mA†	5.5 V						3.85			
V _{OL}	I _{OL} = 50 μA	4.5 V	0.1			0.1		0.1		V
		5.5 V	0.1			0.1		0.1		
	I _{OL} = 24 mA	4.5 V	0.36			0.5		0.44		
		5.5 V	0.36			0.5		0.44		
	I _{OL} = 50 mA†	5.5 V				1.65				
I _{OL} = 75 mA†	5.5 V						1.65			
I _{OZ}	A or B ports§	V _I = V _{CC} or GND	± 0.5			± 10		± 5		μA
I _I	Control inputs	V _I = V _{CC} or GND	± 0.1			± 1		± 1		μA
I _{CC}		V _I = V _{CC} or GND, I _O = 0	8			160		80		μA
ΔI _{CC} ‡		V _I = V _{CC} or GND	0.9			1		1		mA
C _i	Control inputs	V _I = V _{CC} or GND	5 V			4.5			pF	
C _{iO}	A or B ports	V _I = V _{CC} or GND	5 V			10			pF	

† Not more than one output should be tested at a time, and the duration of the test should not exceed 10 ms.

‡ This is the increase in supply current for each input that is at one of the specified TTL voltage levels rather than 0 V to V_{CC}.

§ For I/O ports, the parameter I_{OZ} includes the input leakage current.

timing requirements over recommended operating free-air temperature range, V_{CC} = 5 V ± 0.5 V (unless otherwise noted) (see Note 2)

		T _A = 25°C		54ACT11651		74ACT11651		UNIT
		MIN	MAX	MIN	MAX	MIN	MAX	
f _{clock}	Clock frequency	0	90	0	90	0	90	MHz
t _w	Pulse duration, CAB or CBA high or low	5.5		5		5.5		ns
t _{su}	Setup time, A before CAB† or B before CBA†	4.5		4		4.5		ns
t _h	Hold time, A after CAB† or B after CBA†	2		2		2		ns

NOTE 2: Load circuit and voltage waveforms are shown in Section 1.

PRODUCT PREVIEW information concerns products in the formative or design phase of development. Characteristic data and other specifications are design goals. Texas Instruments reserves the right to change or discontinue these products without notice.



54ACT11651, 74ACT11651 OCTAL BUS TRANSCEIVERS AND REGISTERS

D3445, MARCH 1990—REVISED OCTOBER 1990

switching characteristics over recommended operating free-air temperature range,
 $V_{CC} = 5\text{ V} \pm 0.5\text{ V}$ (unless otherwise noted) (see Note 2)

PARAMETER	FROM (INPUT)	TO (OUTPUT)	$T_A = 25^\circ\text{C}$			54ACT11651		74ACT11651		UNIT
			MIN	TYP	MAX	MIN	MAX	MIN	MAX	
f_{max}			90			90		90		MHz
t_{PLH}	A or B	B or A	2.6	5.6	8.9	2.6	10.7	2.6	9.9	ns
t_{PHL}			4.7	7.7	10.7	4.7	12.8	4.7	11.9	
t_{PLH}	CBA or CAB	A or B	5.5	8.4	11.2	5.5	13.8	5.5	12.7	ns
t_{PHL}			6.3	9.5	12.7	6.3	15.3	6.3	14.1	
t_{PLH}	SBA or SAB [†] with A or B high	A or B	4.8	7.6	10.4	4.8	12.9	4.8	11.8	ns
t_{PHL}			4.1	7.7	11.2	4.1	13.3	4.1	12.4	
t_{PLH}	SBA or SAB [†] with A or B low	A or B	3	6.2	9.3	3	10.4	3	10.4	ns
t_{PHL}			5.6	8.7	11.7	5.6	14.1	5.6	13	
t_{PZH}	$\overline{\text{G}}\text{BA}$	A	4	7.4	10.7	4	12.9	4	11.9	ns
t_{PZL}			4.3	8.2	11.9	4.3	14.5	4.3	13.3	
t_{PHZ}	$\overline{\text{G}}\text{BA}$	A	5.9	7.7	9.5	5.9	10.4	5.9	10	ns
t_{PLZ}			5.1	6.9	8.7	5.1	9.6	5.1	9.2	
t_{PZH}	GAB	B	5.9	9	12.1	5.9	15.1	5.9	13.7	ns
t_{PZL}			6.4	9.8	13.2	6.4	16.3	6.4	14.9	
t_{PHZ}	GAB	B	4.7	7.1	9.5	4.7	10.7	4.7	10	ns
t_{PLZ}			3.8	6.1	8.4	3.8	9.1	3.8	8.8	

[†] These parameters are measured with the internal output state of the storage register opposite to that of the bus input.

NOTE 2: Load circuits and voltage waveforms are shown in Section 1.

operating characteristics, $V_{CC} = 5\text{ V}$, $T_A = 25^\circ\text{C}$

PARAMETER		TEST CONDITIONS		TYP	UNIT
C_{pd}	Power dissipation capacitance per gate	Outputs enabled	$C_L = 50\text{ pF}$, $f = 1\text{ MHz}$	61	pF
		Outputs disabled		15	

PRODUCT PREVIEW information concerns products in the formative or design phase of development. Characteristic data and other specifications are design goals. Texas Instruments reserves the right to change or discontinue these products without notice.

