

# HD74AC623/HD74ACT623 • Octal Bus Transceiver with 3-State Output

## Description

The 'AC623 is an octal transceiver featuring non-inverting 3-state bus compatible outputs in both send and receive directions.

These octal bus transceivers are designed for asynchronous two-way data flow between data buses. The control function implementation allows for maximum flexibility in timing.

These devices allow data transmission from the A bus to the B bus or from the B bus to the A Bus depending upon the logic levels at the enable inputs ( $\overline{\text{GBA}}$  and GAB).

The enable inputs can be used to disable the device so that the buses are effectively isolated.

The dual-enable configuration gives the 'AC623 the capability to store data by simultaneous enabling of  $\overline{\text{GBA}}$  and GAB. Each output reinforces its input in this transceiver configuration. Thus, when both control inputs are enabled and all other data sources to the two sets of the bus lines are at high impedance, both sets of bus lines (sixteen in all) will remain at their last states.

## Features

- Octal Bidirectional Bus interface
- Output Source/Sink 24mA

## Logic Symbol

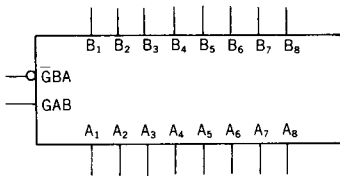

## Pin Assignment

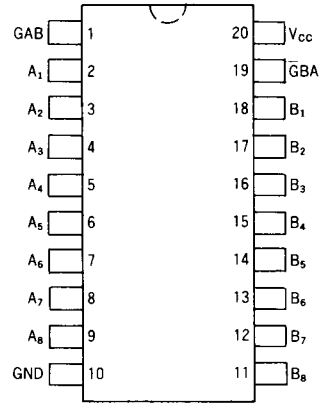

(Top View)

## Pin Names

- $\overline{\text{GBA}}$ , GAB Enable Input
- A<sub>1</sub>-A<sub>8</sub> A Inputs or 3-State Outputs
- A<sub>1</sub>-A<sub>8</sub> B Inputs or 3-State Outputs

## Function Table

Enable Inputs		Operation
$\overline{\text{GBA}}$	GAB	
L	L	B data to A bus
H	H	A data to B bus
H	L	Z
L	H	B data to A bus A data to B bus

H = High Voltage Level  
L = Low Voltage Level  
Z = High Impedance

# HD74AC623/HD74ACT623

## Logic Diagram

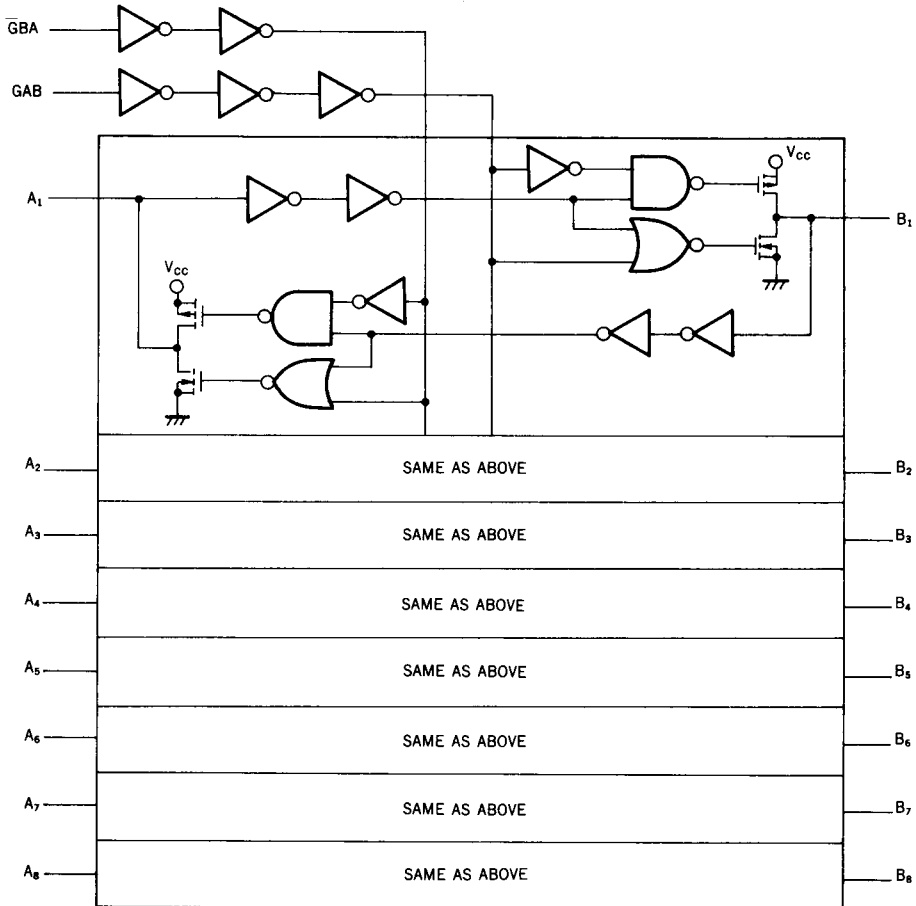

## DC Characteristics (unless otherwise specified)

Symbol	Parameter	Max	Unit	Condition
$I_{CC}$	Maximum Quiescent Supply Current	80	$\mu A$	$V_{IN} = V_{CC}$ or Ground, $V_{CC} = 5.5V$ , $T_a = \text{Worst Case}$
$I_{CC}$	Maximum Quiescent Supply Current	8.0	$\mu A$	$V_{IN} = V_{CC}$ or Ground, $V_{CC} = 5.5V$ , $T_a = 25^\circ C$
$I_{CCr}$	Maximum Additional $I_{CC}$ /Input (HD74ACT623)	1.5	mA	$V_{IN} = V_{CC} - 2.1V$ $V_{CC} = 5.5V$ , $T_a = \text{Worst Case}$

## AC Characteristics: HD74AC623

Symbol	Parameter	V <sub>cc</sub> * (V)	T <sub>a</sub> = +25°C C <sub>L</sub> = 50pF			T <sub>a</sub> = -40°C to +85°C C <sub>L</sub> = 50pF		Unit
			Min	Typ	Max	Min	Max	
t <sub>PLH</sub>	Propagation Delay Data to Output	3.3	1.0	6.0	9.0	1.0	10.0	ns
		5.0	1.0	5.0	7.0	1.0	7.5	
t <sub>PHL</sub>	Propagation Delay Data to Output	3.3	1.0	6.0	9.0	1.0	10.0	ns
		5.0	1.0	4.5	7.0	1.0	7.5	
t <sub>PZH</sub>	Output Enable Time	3.3	1.0	6.5	12.5	1.0	13.0	ns
		5.0	1.0	5.5	9.0	1.0	9.5	
t <sub>PZL</sub>	Output Enable Time	3.3	1.0	7.0	12.0	1.0	13.0	ns
		5.0	1.0	5.5	9.0	1.0	9.5	
t <sub>PHZ</sub>	Output Disable Time	3.3	1.0	8.0	12.0	1.0	12.5	ns
		5.0	1.0	6.5	10.0	1.0	10.5	
t <sub>PLZ</sub>	Output Disable Time	3.3	1.0	7.0	12.5	1.0	13.5	ns
		5.0	1.0	6.0	10.0	1.0	10.5	

\* Voltage Range 3.3 is 3.3V ± 0.3V  
Voltage Range 5.0 is 5.0V ± 0.5V

## AC Characteristics: HD74ACT623

Symbol	Parameter	V <sub>cc</sub> * (V)	T <sub>a</sub> = +25°C C <sub>L</sub> = 50pF			T <sub>a</sub> = -40°C to +85°C C <sub>L</sub> = 50pF		Unit
			Min	Typ	Max	Min	Max	
t <sub>PLH</sub>	Propagation Delay Data to Output	5.0	1.0	6.0	9.0	1.0	10.0	ns
t <sub>PHL</sub>	Propagation Delay Data to Output	5.0	1.0	5.5	9.0	1.0	10.0	ns
t <sub>PZH</sub>	Output Enable Time	5.0	1.0	6.5	9.0	1.0	10.0	ns
t <sub>PZL</sub>	Output Enable Time	5.0	1.0	5.0	10.0	1.0	11.0	ns
t <sub>PHZ</sub>	Output Disable Time	5.0	1.0	9.0	10.5	1.0	11.5	ns
t <sub>PLZ</sub>	Output Disable Time	5.0	1.0	7.0	10.5	1.0	11.5	ns

\* Voltage Range 5.0 is 5.0V ± 0.5V

## Capacitance

Symbol	Parameter	Typ	Unit	Condition
C <sub>IN</sub>	Input Capacitance	4.5	pF	V <sub>cc</sub> = 5.5V
C <sub>I/O</sub>	Input/Output Capacitance	15.0	pF	V <sub>cc</sub> = 5.5V
C <sub>PD</sub>	Power Dissipation Capacitance	30.0	pF	V <sub>cc</sub> = 5.0V