

**ADVANCED  
POWER  
TECHNOLOGY®**  
**2N7227 400 Volt 0.315Ω**  
**JX2N7227\***  
**JV2N7227\***

## POWER MOS IV™

\*QUALIFIED TO MIL-S-19500/592 31/7/92

### JEDEC REGISTERED N - CHANNEL HIGH VOLTAGE POWER MOSFETS

#### MAXIMUM RATINGS

All Ratings:  $T_C = 25^\circ\text{C}$  unless otherwise specified.

Symbol	Parameter	2N7227	UNIT
$V_{DSS}$	Drain-Source Voltage	400	Volts
$V_{GS}$	Gate-Source Voltage	$\pm 20$	
$I_D$	Continuous Drain Current @ $T_C = 25^\circ\text{C}$	14	Amps
	Continuous Drain Current @ $T_C = 100^\circ\text{C}$	9	
$I_{DM}$	Pulsed Drain Current <sup>①</sup>	56	
$I_{AR}$	Avalanche Current <sup>①</sup>	14	
$P_D$	Total Power Dissipation @ $T_C = 25^\circ\text{C}$	150	Watts
	Total Power Dissipation @ $T_C = 100^\circ\text{C}$	60	
	Linear Derating Factor	1.2	W/K
$E_{AS}$	Single Pulse Avalanche Energy	700	mJ
$E_{AR}$	Repetitive Avalanche Energy	15	
$T_J, T_{STG}$	Operating and Storage Junction Temperature Range	-55 to 150	$^\circ\text{C}$
$T_L$	Max. Lead Temp. for Soldering Conditions: 0.063" from Case for 10 Sec.	300	

#### STATIC ELECTRICAL CHARACTERISTICS

Symbol	Characteristic / Test Conditions	MIN	TYP	MAX	UNIT
$BV_{DSS}$	Drain-Source Breakdown Voltage ( $V_{GS} = 0V, I_D = 250\mu\text{A}$ )	400			Volts
$V_{GS(TH)}$	Gate Threshold Voltage ( $V_{DS} = V_{GS}, I_D = 250\mu\text{A}$ )	2		4	
$I_{DSS}$	Zero Gate Voltage Drain Current ( $V_{DS} = 0.8 V_{DSS}, V_{GS} = 0V$ )			25	$\mu\text{A}$
	Zero Gate Voltage Drain Current ( $V_{DS} = 0.8 V_{DSS}, V_{GS} = 0V, T_C = 125^\circ\text{C}$ )			250	
$I_{GSS}$	Gate-Source Leakage Current ( $V_{GS} = \pm 20V, V_{DS} = 0V$ )			$\pm 100$	nA
$I_D(ON)$	On State Drain Current <sup>②</sup> ( $V_{DS} > I_D(ON) \times R_{DS(ON)}$ Max, $V_{GS} = 10V$ )	14			Amps
$R_{DS(ON)}$	Drain-Source On-State Resistance <sup>②</sup> ( $V_{GS} = 10V, I_D = 9.0A$ )			0.315	Ohms
	Drain-Source On-State Resistance <sup>②</sup> ( $V_{GS} = 10V, I_D = 9.0A, T_C = 125^\circ\text{C}$ )			0.680	
	Drain-Source On-State Resistance <sup>②</sup> ( $V_{GS} = 10V, I_D = 14.0A$ )			0.415	

**CAUTION:** These Devices are Sensitive to Electrostatic Discharge. Proper Handling Procedures Should Be Followed.

APT Website - <http://www.advancedpower.com>

USA  
405 S.W. Columbia Street  
EUROPE

Avenue J.F. Kennedy Bât B4 Parc Cadéra Nord

Bend, Oregon 97702-1035

F-33700 Merignac - France

Phone: (541) 382-8028

Phone: (33) 5 57 92 15 15

FAX: (541) 388-0364

FAX: (33) 5 56 47 97 61

### DYNAMIC CHARACTERISTICS

2N7227

Symbol	Characteristic	Test Conditions	MIN	TYP	MAX	UNIT
$C_{DC}$	Drain-to-Case Capacitance	$f = 1 \text{ MHz}$		12	24	pF
$C_{iss}$	Input Capacitance	$V_{GS} = 0V$		2400	2800	
$C_{oss}$	Output Capacitance	$V_{DS} = 25V$		385	540	
$C_{rss}$	Reverse Transfer Capacitance	$f = 1 \text{ MHz}$		160	240	
$Q_g$	Total Gate Charge	$V_{GS} = 10V$		100	150	nC
$Q_{gs}$	Gate-Source Charge	$V_{DD} = 0.5 V_{DSS}$		12	24	
$Q_{gd}$	Gate-Drain ("Miller") Charge	$I_D = I_D [\text{Cont.}] @ 25^\circ\text{C}$		41	65	
$t_d(\text{on})$	Turn-on Delay Time	$V_{GS} = 10V$		12	35	ns
$t_r$	Rise Time	$V_{DD} = 0.5 V_{DSS}$		18	190	
$t_d(\text{off})$	Turn-off Delay Time	$I_D = I_D [\text{Cont.}] @ 25^\circ\text{C}$		40	170	
$t_f$	Fall Time	$R_G = 2.35\Omega$		13	130	

### SOURCE-DRAIN DIODE RATINGS AND CHARACTERISTICS

Symbol	Characteristic / Test Conditions	MIN	TYP	MAX	UNIT
$I_S$	Continuous Source Current (Body Diode)			14	Amps
$I_{SM}$	Pulsed Source Current <sup>①</sup> (Body Diode)			56	
$V_{SD}$	Diode Forward Voltage <sup>②</sup> ( $V_{GS} = 0V, I_S = -I_D [\text{Cont.}]$ )			1.7	Volts
$t_{rr}$	Reverse Recovery Time ( $I_S = -I_D [\text{Cont.}], di_S/dt = 100A/\mu s$ )		279	1200	ns
$Q_{rr}$	Reverse Recovery Charge ( $I_S = -I_D [\text{Cont.}], di_S/dt = 100A/\mu s$ )		3.6	9.0	$\mu\text{C}$

### THERMAL CHARACTERISTICS

Symbol	Characteristic	MIN	TYP	MAX	UNIT
$R_{\theta JC}$	Junction to Case			0.83	K/W <sup>③</sup>
$R_{\theta JA}$	Junction to Ambient			31	

① Repetitive Rating: Pulse width limited by maximum junction temperature. See Transient Thermal Impedance Curve. (Fig.1)

② Pulse Test: Pulse width < 380  $\mu\text{s}$ , Duty Cycle < 2%

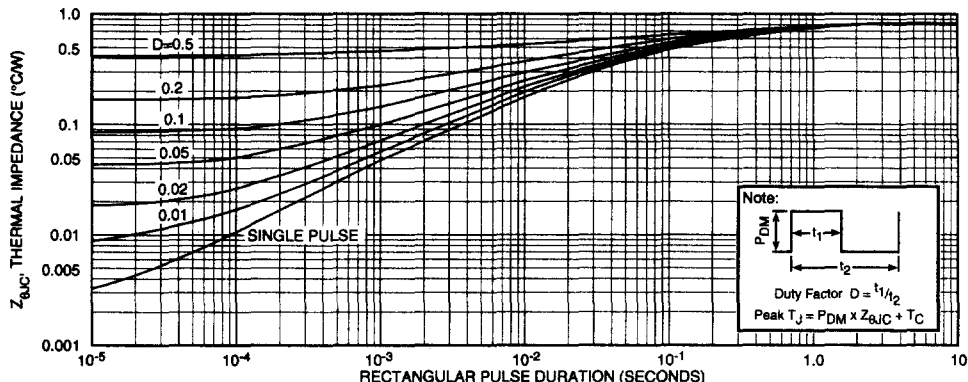
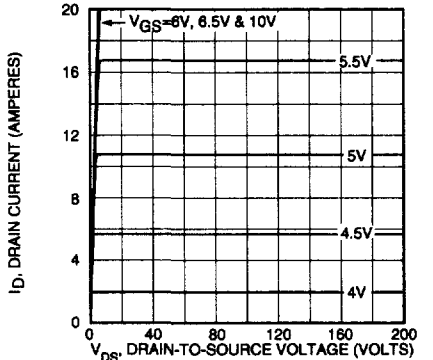
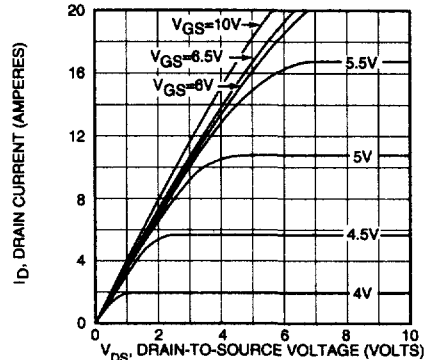

FIGURE 1, MAXIMUM EFFECTIVE TRANSIENT THERMAL IMPEDANCE, JUNCTION-TO-CASE vs PULSE DURATION

**2N7227**



**FIGURE 2, TYPICAL OUTPUT CHARACTERISTICS**



**FIGURE 3, TYPICAL OUTPUT CHARACTERISTICS**

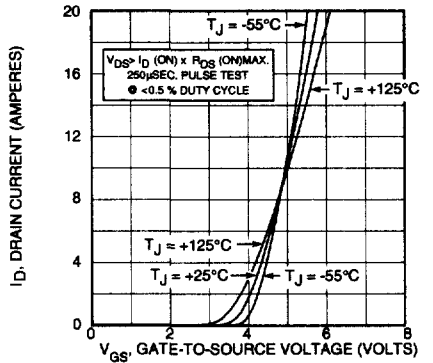

**FIGURE 4, TYPICAL TRANSFER CHARACTERISTICS**

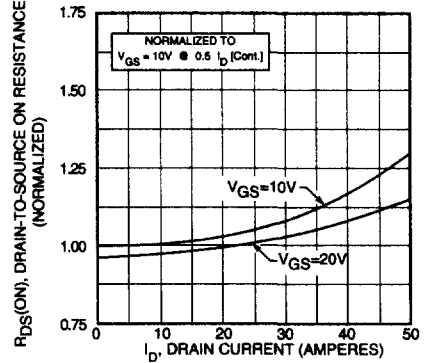

**FIGURE 5,  $R_{DS(ON)}$  vs DRAIN CURRENT**

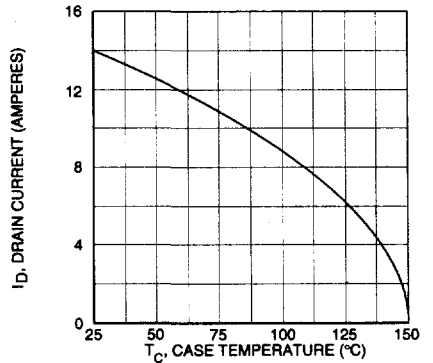

**FIGURE 6, MAXIMUM DRAIN CURRENT vs CASE TEMPERATURE**

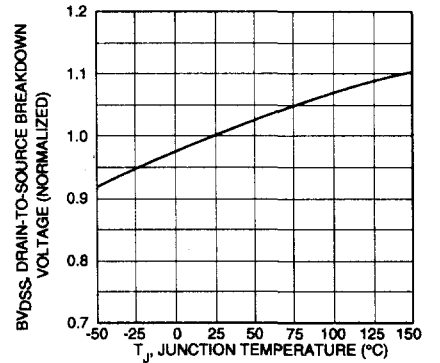

**FIGURE 7, BREAKDOWN VOLTAGE vs TEMPERATURE**

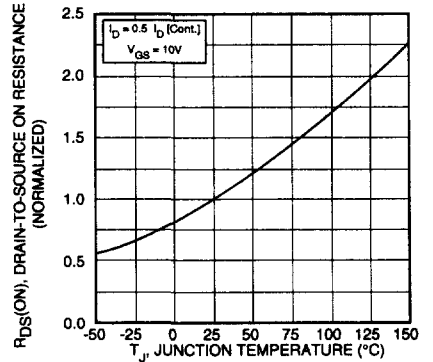

**FIGURE 8, ON-RESISTANCE vs. TEMPERATURE**

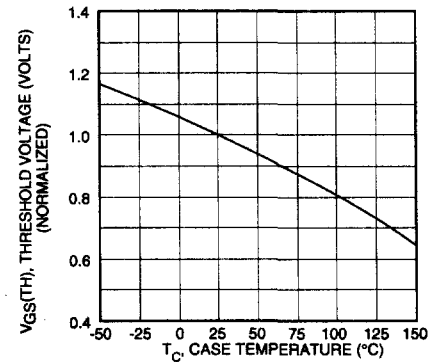

**FIGURE 9, THRESHOLD VOLTAGE vs TEMPERATURE**

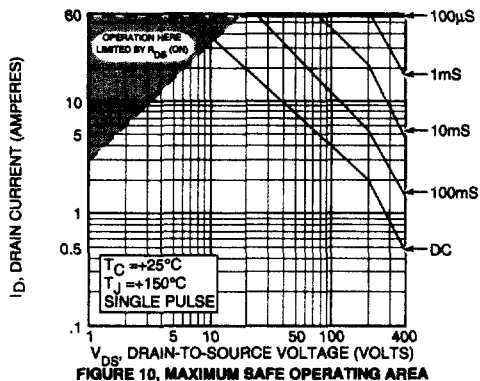

FIGURE 10, MAXIMUM SAFE OPERATING AREA

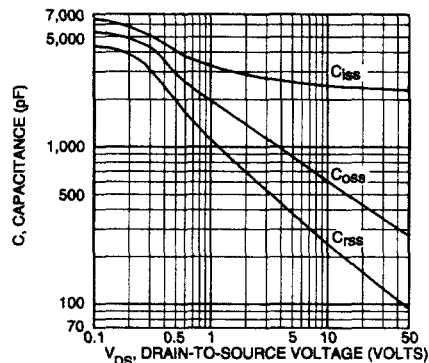

FIGURE 11, TYPICAL CAPACITANCE vs DRAIN-TO-SOURCE VOLTAGE

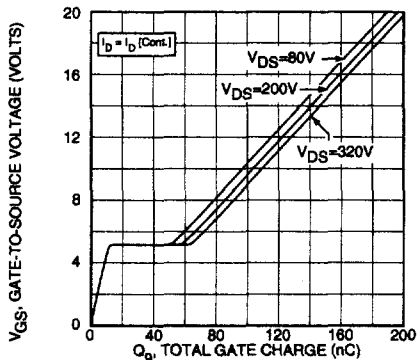

FIGURE 12, GATE CHARGES vs GATE-TO-SOURCE VOLTAGE

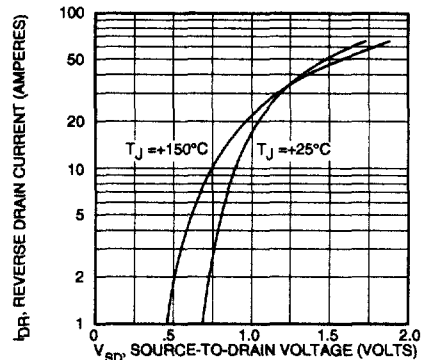
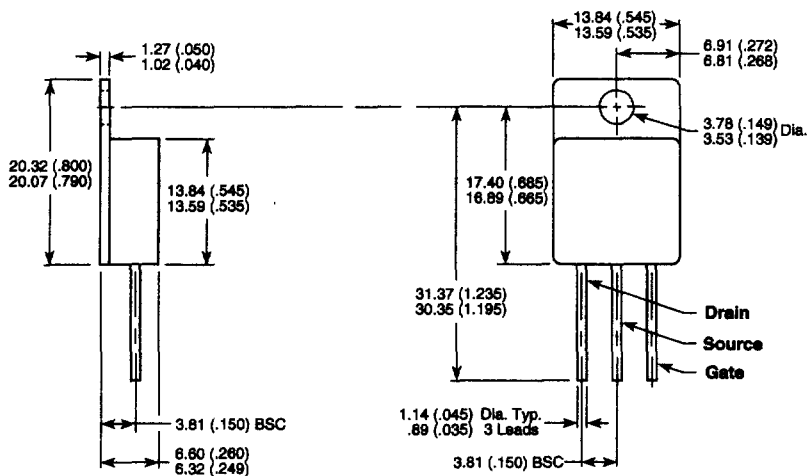

FIGURE 13, TYPICAL SOURCE-DRAIN DIODE FORWARD VOLTAGE

TO-254AA Package Outline



Dimensions in Millimeters and (Inches)