

S3WB□Z

600V 2.3A

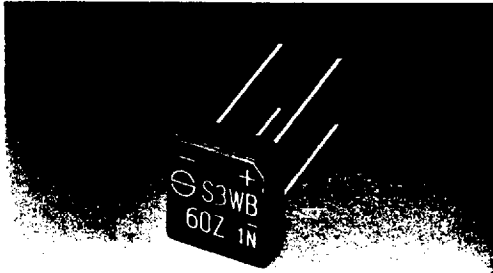

■ 外形寸法図 OUTLINE DIMENSIONS

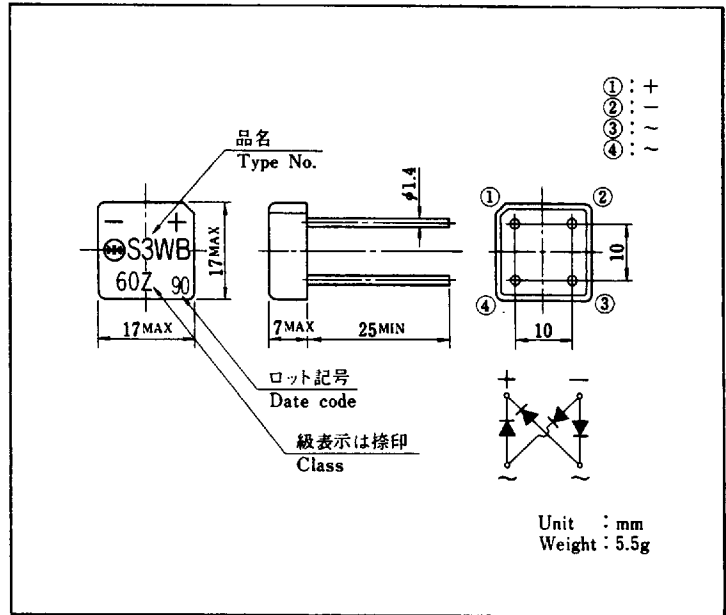

■ 定格表 RATINGS

絶対最大定格 Absolute Maximum Ratings

項目 Item	記号 Symbol	条件 Conditions	品名 Type No.	S3WB60Z	単位 Unit
保存温度 Storage Temperature	Tstg			-40~150	°C
接合部温度 Operating Junction Temperature	Tj			150	°C
せん頭逆電圧 Maximum Reverse Voltage	V _{RM}			600	V
出力電流 Average Rectified Forward Current	I _O	50Hz 正弦波, 抵抗負荷, プリント基板実装, Ta=40°C 50Hz sine wave, R-load, On glass-epoxi substrate, Ta=40°C		2.3	A
せん頭サージ順電流 Peak Surge Forward Current	I _{FSM}	50Hz 正弦波, 非繰り返し 1 サイクルせん頭値, Tj=25°C 50Hz sine wave, Non-repetitive 1 cycle peak value, Tj=25°C		120	A
電流 2 乗時間積 Current Squared Time	I ² t	1ms ≤ t < 10ms Tc=25°C		35	A ² s
せん頭サージ逆電力 Peak Surge Reverse Power	P _{RSM}	パルス幅 10μs, 非繰り返し, 1 素子当り, Tj=25°C Pulse width 10μs, Non-repetitive, Rating of per diode, Tj=25°C		4	kW

電氣的・熱的特性 Electrical Characteristics (Tj=25°C)

順電圧 Forward Voltage	V _F	I _F =2A, パルス測定, 1 素子当りの規格値 Pulse measurement, Rating of per diode	MAX 1.05	V
逆電流 Reverse Current	I _R	V _R =V _{RM} , パルス測定, 1 素子当りの規格値 Pulse measurement, Rating of per diode	MAX 10	μA
降伏電圧 Avalanche Voltage	V _Z	I _R =1.5mA, 1 素子当りの規格値 Rating of per diode	MIN 1000	V
熱抵抗 Thermal Resistance	θ _{jl}	接合部・リード間 Between junction and lead	MAX 5.5	°C/W
	θ _{ja}	接合部・周囲間 Between junction and ambient	MAX 26.5	

8219387 0002913 294

■ 特性図 CHARACTERISTIC DIAGRAMS

