

256K x 4 Static RAM

Features

- **High speed**
— $t_{AA} = 12$ ns
- **CMOS for optimum speed/power**
- **Low active power**
— **910 mW**
- **Low standby power**
— **275 mW**
- **2.0V data retention (optional)**
— **100 μ W**
- **Automatic power-down when deselected**
- **TTL-compatible inputs and outputs**

Functional Description

The CY7C106A is a high-performance CMOS static RAM organized as 262,144 words by 4 bits. Easy memory expansion is provided by an active LOW chip enable (CE), an active LOW output enable (OE), and three-state drivers. The device has an automatic power-down feature that reduces power consumption by more than 65% when deselected.

Writing to the device is accomplished by taking chip enable (CE) and write enable (WE) inputs LOW. Data on the four I/O pins (I/O₀ through I/O₃) is then written into the location specified on the address pins (A₀ through A₁₇).

Reading from the device is accomplished by taking chip enable (CE) and output enable (OE) LOW while forcing write enable (WE) HIGH. Under these conditions, the contents of the memory location specified by the address pins will appear on the four I/O pins.

The four input/output pins (I/O₀ through I/O₃) are placed in a high-impedance state when the device is deselected (CE HIGH), the outputs are disabled (OE HIGH), or during a write operation (CE and WE LOW).

The CY7C106A is available in standard 400-mil-wide DIPs and SOJs.

2

Logic Block Diagram

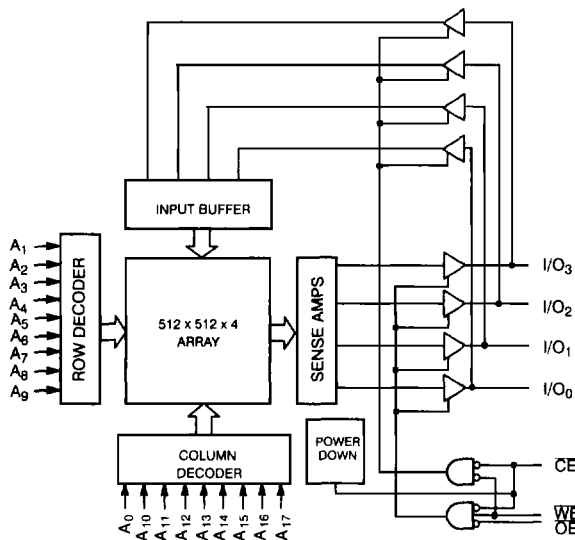

C106A-1

Pin Configuration

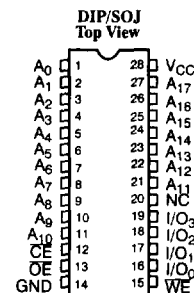

C106A-2

Selection Guide

		7C106A-12	7C106A-15	7C106A-20	7C106A-25	7C106A-35
Maximum Access Time (ns)		12	15	20	25	35
Maximum Operating Current (mA)	Commercial	165	155	140	130	125
	Military		165	150	140	135
Maximum Standby Current (mA)	Commercial	50	40	30	30	25
	Military		40	30	30	25



Maximum Ratings

(Above which the useful life may be impaired. For user guidelines, not tested.)

- Storage Temperature -65°C to +150°C
- Ambient Temperature with Power Applied -55°C to +125°C
- Supply Voltage on V_{CC} Relative to GND^[1] -0.5V to +7.0V
- DC Voltage Applied to Outputs in High Z State^[1] -0.5V to V_{CC} + 0.5V
- DC Input Voltage^[1] -0.5V to V_{CC} + 0.5V
- Current into Outputs (LOW) 20 mA

Static Discharge Voltage >2001V (per MIL-STD-883, Method 3015)

Latch-Up Current >200 mA

Operating Range

Range	Ambient Temperature ^[2]	V _{CC}
Commercial	0°C to +70°C	5V ± 10%
Military	-55°C to +125°C	5V ± 10%

Electrical Characteristics Over the Operating Range^[3]

Parameter	Description	Test Conditions	7C106A-12		7C106A-15		7C106A-20		Unit
			Min.	Max.	Min.	Max.	Min.	Max.	
V _{OH}	Output HIGH Voltage	V _{CC} = Min., I _{OH} = - 4.0 mA	2.4		2.4		2.4		V
V _{OL}	Output LOW Voltage	V _{CC} = Min., I _{OL} = 8.0 mA		0.4		0.4		0.4	V
V _{IH}	Input HIGH Voltage		2.2	V _{CC} + 0.3	2.2	V _{CC} + 0.3	2.2	V _{CC} + 0.3	V
V _{IL}	Input LOW Voltage ^[1]		-0.3	0.8	-0.3	0.8	-0.3	0.8	V
I _{Ix}	Input Load Current	GND ≤ V _I ≤ V _{CC}	-1	+1	-1	+1	-1	+1	µA
I _{OZ}	Output Leakage Current	GND ≤ V _I ≤ V _{CC} , Output Disabled	-5	+5	-5	+5	-5	+5	µA
I _{OS}	Output Short Circuit Current ^[4]	V _{CC} = Max., V _{OUT} = GND		-300		-300		-300	mA
I _{CC}	V _{CC} Operating Supply Current	V _{CC} = Max., I _{OUT} = 0 mA, f = f _{MAX} = 1/τ _{RC}	Com'l	165		155		140	mA
			Mil			165		150	
I _{SB1}	Automatic CE Power-Down Current — TTL Inputs	Max. V _{CC} , CE ≥ V _{IH} , V _{IN} ≥ V _{IH} or V _{IN} ≤ V _{IL} , f = f _{MAX}	Com'l	50		40		30	mA
			Mil			40		30	
I _{SB2}	Automatic CE Power-Down Current — CMOS Inputs	Max. V _{CC} , CE ≥ V _{CC} - 0.3V, V _{IN} ≥ V _{CC} - 0.3V or V _{IN} ≤ 0.3V, f=0	Com'l	2		2		2	mA
			Mil			2		2	

Notes:

1. V_{IL} (min.) = - 2.0V for pulse durations of less than 20 ns.
2. T_A is the "instant on" case temperature.
3. See the last page of this specification for Group A subgroup testing information.
4. Not more than 1 output should be shorted at one time. Duration of the short circuit should not exceed 30 seconds.

Electrical Characteristics Over the Operating Range^[3] (continued)

Parameter	Description	Test Conditions	7C106A-25		7C106A-35		Unit
			Min.	Max.	Min.	Max.	
V _{OH}	Output HIGH Voltage	V _{CC} = Min., I _{OH} = -4.0 mA	2.4		2.4		V
V _{OL}	Output LOW Voltage	V _{CC} = Min., I _{OL} = 8.0 mA		0.4		0.4	V
V _{IH}	Input HIGH Voltage		2.2	V _{CC} + 0.3	2.2	V _{CC} + 0.3	V
V _{IL}	Input LOW Voltage ^[1]		-0.3	0.8	-0.3	0.8	V
I _{IX}	Input Load Current	GND ≤ V _I ≤ V _{CC}	-1	+1	-1	+1	μA
I _{OZ}	Output Leakage Current	GND ≤ V _I ≤ V _{CC} , Output Disabled	-5	+5	-5	+5	μA
I _{OS}	Output Short Circuit Current ^[4]	V _{CC} = Max., V _{OUT} = GND		-300		-300	mA
I _{CC}	V _{CC} Operating Supply Current	V _{CC} = Max., I _{OUT} = 0 mA, f = f _{MAX} = 1/t _{RC}	Com'1	130		125	mA
			Mil	140		135	
I _{SB1}	Automatic CE Power-Down Current — TTL Inputs	Max. V _{CC} , $\overline{CE} \geq V_{IH}$, V _{IN} ≥ V _{IH} or V _{IN} ≤ V _{IL} , f = f _{MAX}	Com'1	30		25	mA
			Mil	30		25	
I _{SB2}	Automatic CE Power-Down Current — CMOS Inputs	Max. V _{CC} , $\overline{CE} \geq V_{CC} - 0.3V$, V _{IN} ≥ V _{CC} - 0.3V or V _{IN} ≤ 0.3V, f=0	Com'1	2		2	mA
			Mil	2		2	

2
Capacitance^[5]

Parameter	Description	Test Conditions	Max.	Unit
C _{IN} : Addresses	Input Capacitance	T _A = 25°C, f = 1 MHz, V _{CC} = 5.0V	7	pF
C _{IN} : Controls			10	
C _{OUT}	Output Capacitance		10	pF

Note:

5. Tested initially and after any design or process changes that may affect these parameters.

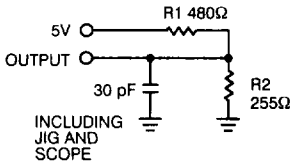
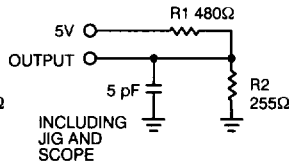
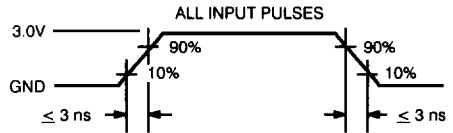
AC Test Loads and Waveforms

(a) Normal Load

(b) High-Z Load

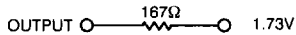
C106A-4

Equivalent to: THÉVENIN EQUIVALENT



C106A-3

Switching Characteristics Over the Operating Range^[3, 6]

Parameter	Description	7C106A-12		7C106A-15		7C106A-20		7C106A-25		7C106A-35		Unit
		Min.	Max.	Min.	Max.	Min.	Max.	Min.	Max.	Min.	Max.	
READ CYCLE												
t _{RC}	Read Cycle Time	12		15		20		25		35		ns
t _{AA}	Address to Data Valid		12		15		20		25		35	ns
t _{OHA}	Data Hold from Address Change	3		3		3		3		3		ns
t _{ACE}	\overline{CE} LOW to Data Valid		12		15		20		25		35	ns
t _{DOE}	\overline{OE} LOW to Data Valid		6		7		8		10		10	ns
t _{LZOE}	\overline{OE} LOW to Low Z	0		0		0		0		0		ns
t _{HZOE}	\overline{OE} HIGH to High Z ^[7, 8]		6		7		8		10		10	ns
t _{LZCE}	\overline{CE} LOW to Low Z ^[8]	3		3		3		3		3		ns
t _{HZCE}	\overline{CE} HIGH to High Z ^[7, 8]		6		7		8		10		10	ns
t _{PU}	\overline{CE} LOW to Power-Up	0		0		0		0		0		ns
t _{PD}	\overline{CE} HIGH to Power-Down		12		15		20		25		35	ns
WRITE CYCLE^[9, 10]												
t _{WC}	Write Cycle Time	12		15		20		25		35		ns
t _{SCE}	\overline{CE} LOW to Write End	10		12		15		20		25		ns
t _{AW}	Address Set-Up to Write End	10		12		15		20		25		ns
t _{HA}	Address Hold from Write End	0		0		0		0		0		ns
t _{SA}	Address Set-Up to Write Start	0		0		0		0		0		ns
t _{PWE}	\overline{WE} Pulse Width	10		12		15		20		25		ns
t _{SD}	Data Set-Up to Write End	7		8		10		15		20		ns
t _{HD}	Data Hold from Write End	0		0		0		0		0		ns
t _{LZWE}	\overline{WE} HIGH to Low Z ^[8]	2		3		3		3		3		ns
t _{HZWE}	\overline{WE} LOW to High Z ^[7, 8]		6		7		8		10		10	ns

Notes:

- Test conditions assume signal transition time of 3 ns or less, timing reference levels of 1.5V, input pulse levels of 0 to 3.0V, and output loading of the specified I_{OL}/I_{OHI} and 30-pF load capacitance.
- t_{HZOE}, t_{HZCE}, and t_{HZWE} are specified with a load capacitance of 5 pF as in part (b) of AC Test Loads. Transition is measured ±500 mV from steady-state voltage.
- At any given temperature and voltage condition, t_{HZCE} is less than t_{LZCE}, t_{HZOE} is less than t_{LZOE}, and t_{HZWE} is less than t_{LZWE} for any given device.
- The internal write time of the memory is defined by the overlap of \overline{CE} and \overline{WE} LOW. \overline{CE} and \overline{WE} must be LOW to initiate a write, and the transition of either of these signals can terminate the write. The input data set-up and hold timing should be referenced to the leading edge of the signal that terminates the write.
- The minimum write cycle time for Write Cycle No. 3 (\overline{WE} controlled, \overline{OE} LOW) is the sum of t_{HZWE} and t_{SD}.

Data Retention Characteristics Over the Operating Range (L Version Only)

Parameter	Description	Conditions ^[11]	Commercial		Military		Unit
			Min.	Max.	Min.	Max.	
V _{DR}	V _{CC} for Data Retention		2.0		2.0		V
I _{CCDR}	Data Retention Current	V _{CC} = V _{DR} = 2.0V, CE ≥ V _{CC} - 0.3V, V _{IN} ≥ V _{CC} - 0.3V or V _{IN} ≤ 0.3V		50		70	μA
t _{CDR} ^[5]	Chip Deselect to Data Retention Time		0		0		ns
t _R ^[5]	Operation Recovery Time		t _{RC}		t _{RC}		ns

2

Data Retention Waveform

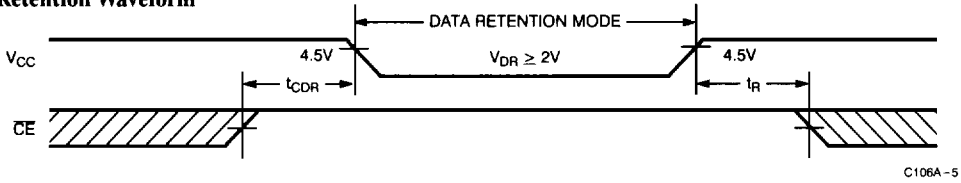

Switching Waveforms

Read Cycle No. 1^[12, 13]

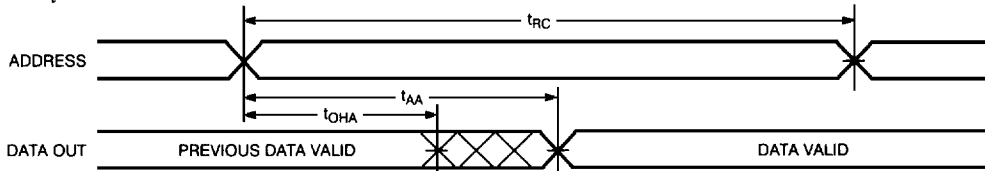

Read Cycle No. 2 (OE Controlled)^[13, 14]

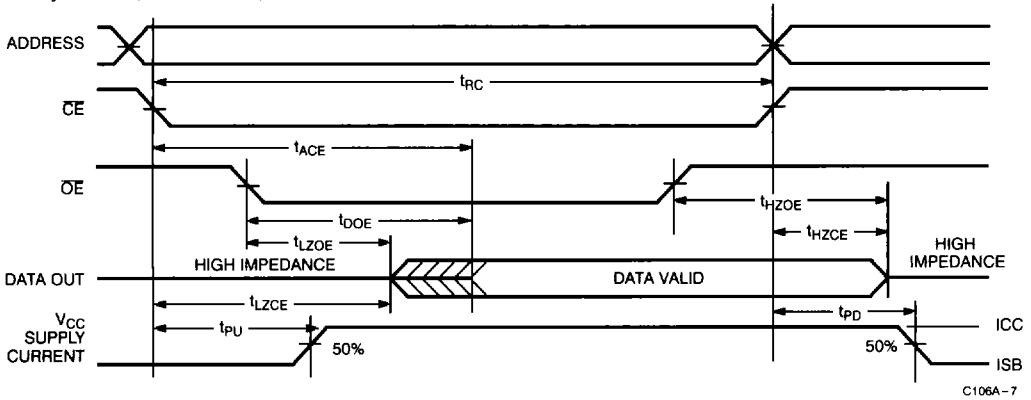

Notes:

- 11. No input may exceed V_{CC} + 0.5V.
- 12. Device is continuously selected, OE and CE = V_{IL}.

- 13. WE is HIGH for read cycle.
- 14. Address valid prior to or coincident with CE transition LOW.



Switching Waveforms (continued)

Write Cycle No. 1 (\overline{CE} Controlled)^[15, 16]

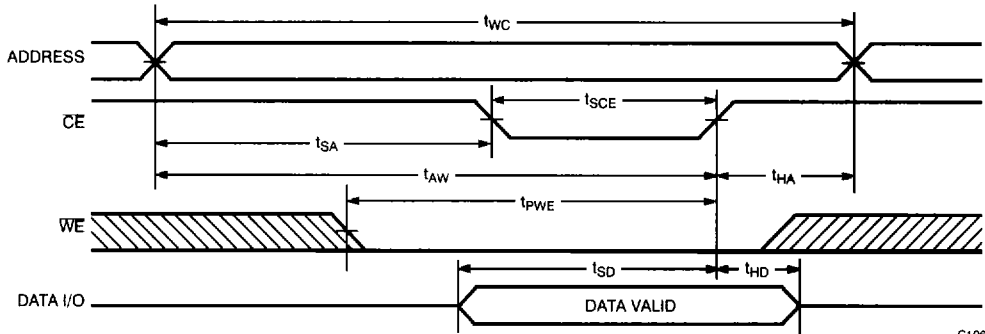

C106A-8

Write Cycle No. 2 (\overline{WE} Controlled, \overline{OE} HIGH During Write)^[15, 16]

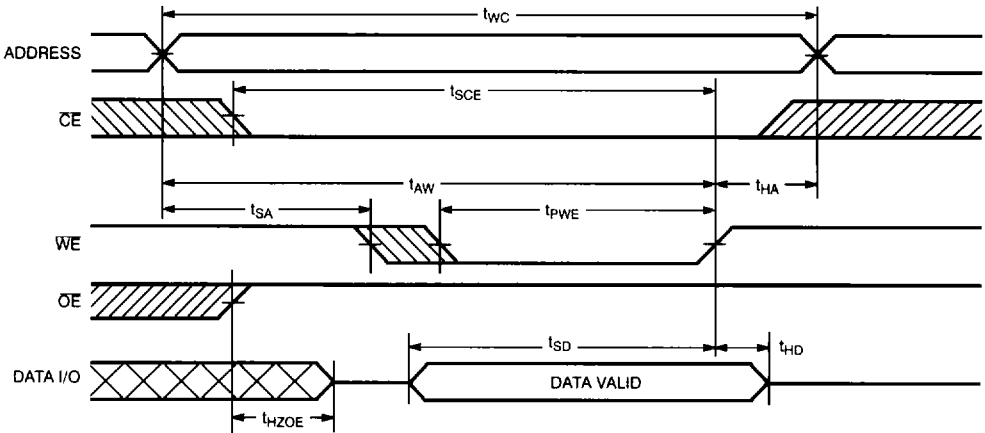

C106A-9

Notes:

- 15. If \overline{CE} goes HIGH simultaneously with \overline{WE} going HIGH, the output remains in a high-impedance state.
- 16. Data I/O is high impedance if $\overline{OE} = V_{IH}$.

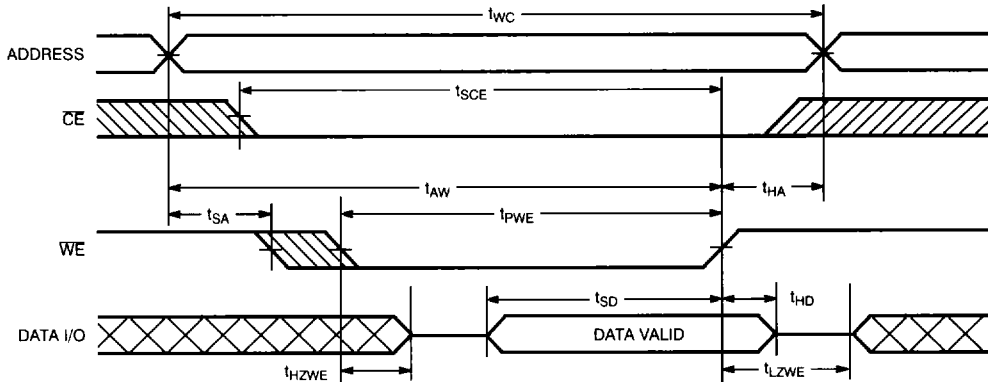
Switching Waveforms
Write Cycle No. 3 (\overline{WE} Controlled, \overline{OE} LOW)^[10, 16]

C106A-10

Truth Table

\overline{CE}	\overline{OE}	\overline{WE}	Input/Output	Mode	Power
H	X	X	High Z	Power-Down	Standby (I_{SB})
L	L	H	Data Out	Read	Active (I_{CC})
L	X	L	Data In	Write	Active (I_{CC})
L	H	H	High Z	Selected, Outputs Disabled	Active (I_{CC})

Ordering Information

Speed (ns)	Ordering Code	Package Name	Package Type	Operating Range
12	CY7C106A-12PC	P41	28-Lead (400-Mil) Molded DIP	Commercial
	CY7C106A-12VC	V28	28-Lead (400-Mil) Molded SOJ	
15	CY7C106A-15PC	P41	28-Lead (400-Mil) Molded DIP	Commercial
	CY7C106A-15VC	V28	28-Lead (400-Mil) Molded SOJ	
	CY7C106A-15DMB	D42	28-Lead (400-Mil) CerDIP	Military
20	CY7C106A-20PC	P41	28-Lead (400-Mil) Molded DIP	Commercial
	CY7C106A-20VC	V28	28-Lead (400-Mil) Molded SOJ	
	CY7C106A-20DMB	D42	28-Lead (400-Mil) CerDIP	Military
25	CY7C106A-25PC	P41	28-Lead (400-Mil) Molded DIP	Commercial
	CY7C106A-25VC	V28	28-Lead (400-Mil) Molded SOJ	
	CY7C106A-25DMB	D42	28-Lead (400-Mil) CerDIP	Military
35	CY7C106A-35PC	P41	28-Lead (400-Mil) Molded DIP	Commercial
	CY7C106A-35VC	V28	28-Lead (400-Mil) Molded SOJ	
	CY7C106A-35DMB	D42	28-Lead (400-Mil) CerDIP	Military

Contact factory for "E" version availability.



MILITARY SPECIFICATIONS
Group A Subgroup Testing

DC Characteristics

Parameter	Subgroups
V _{OH}	1, 2, 3
V _{OL}	1, 2, 3
V _{IH}	1, 2, 3
V _{IL Max.}	1, 2, 3
I _{Ix}	1, 2, 3
I _{OZ}	1, 2, 3
I _{CC}	1, 2, 3
I _{SB1}	1, 2, 3
I _{SB2}	1, 2, 3

Switching Characteristics

Parameter	Subgroups
READ CYCLE	
t _{RC}	7, 8, 9, 10, 11
t _{AA}	7, 8, 9, 10, 11
t _{OHA}	7, 8, 9, 10, 11
t _{ACE}	7, 8, 9, 10, 11
t _{DOE}	7, 8, 9, 10, 11
WRITE CYCLE	
t _{WC}	7, 8, 9, 10, 11
t _{SCE}	7, 8, 9, 10, 11
t _{AW}	7, 8, 9, 10, 11
t _{HA}	7, 8, 9, 10, 11
t _{SA}	7, 8, 9, 10, 11
t _{PWE}	7, 8, 9, 10, 11
t _{SD}	7, 8, 9, 10, 11
t _{HD}	7, 8, 9, 10, 11

Document #: 38-00230-A