

CONNECTOR TYPE	CABLE TYPE	TOOLS REQUIRED:
OSP PANEL FEEDTHROUGH JACK RECEPTACLE THREADED INSTAL.	N/A	TORQUE TOOL: 2588-6097-64

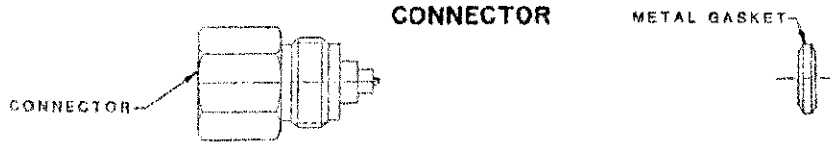

### ASSEMBLY OPERATIONS

- 1.0 MOUNTING HOLE PREPARATION**
- 1.1 DRILL .068 ± .001 DIAMETER PILOT HOLE THROUGH PANEL.
  - 1.2 INSERT STEP REAMER INTO PILOT HOLE AND FEED TO DEPTH SHOWN.
  - 1.3 TAP 250-36 THREAD TO DEPTH SHOWN.
  - 1.4 • PLATE PER CUSTOMER APPLICATION  
RECOMMENDED MAXIMUM TOTAL PLATING IS .00019.
  - 1.5 CLEAN IN SOLVENT.

• PLATING OPTIONAL

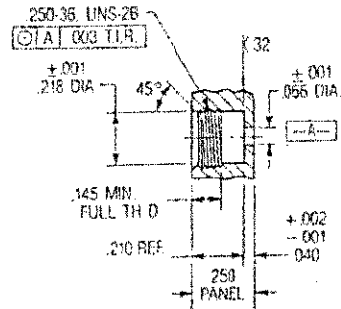

- 2.0 INSTALLATION OF CONNECTOR INTO PANEL**
- 2.1 ASSEMBLE METAL GASKET ON TO CONNECTOR
  - 2.2 THREAD CONNECTOR INTO MOUNTING HOLE.
  - 2.3 USING TORQUE TOOL TORQUE CONNECTOR TO 18 IN-100.
  - 2.4 THIS COMPLETES INSTALLATION OF THE CONNECTOR.

