



PRODUCT OVERVIEW

DATEL's ADS-942A is a functionally complete, 14-bit, 2MHz, sampling A/D converter. Packaged in a 32-pin TDIP, the unit contains a fast-settling sample/hold amplifier, a 14-bit subranging (two-pass) A/D converter, a precision reference, three-state output register, and all the timing/con-

trol logic necessary to operate from a single start convert pulse.

The ADS-942AA is optimized for wideband frequency-domain applications and is fully FFT tested. The ADS-942AA requires $\pm 15V$ and $\pm 5V$ supplies and typically consumes 2.2 Watts.

FEATURES

- 14-bit resolution
- 2MHz minimum throughput
- Low-power, 2.2 Watts
- Functionally complete
- Internal reference and S/H amplifier
- 78dB signal-to-noise ratio
- Full Nyquist-rate sampling
- Small 32-pin TDIP

INPUT/OUTPUT CONNECTIONS			
PIN	FUNCTION	PIN	FUNCTION
1	+10V REF. OUT	32	START CONVERT
2	BIPOLAR	31	BIT 1 OUT (MSB)
3	ANALOG INPUT	30	BIT 2 OUT (MSB)
4	SIGNAL GROUND	29	BIT 3 OUT
5	OFFSET ADJUST	28	BIT 4 OUT
6	ANALOG GROUND	27	BIT 5 OUT
7	OVERFLOW	26	BIT 6 OUT
8	CODING SELECT	25	BIT 7 OUT
9	ENABLE	24	BIT 8 OUT
10	+5V SUPPLY	23	BIT 9 OUT
11	DIGITAL GROUND	22	BIT 10 OUT
12	+15V SUPPLY	21	BIT 11 OUT
13	-15V SUPPLY	20	BIT 12 OUT
14	-5V SUPPLY	19	BIT 13 OUT
15	ANALOG GROUND	18	BIT 14 OUT (LSB)
16	EOC	17	BIT 14 OUT (LSB)

BLOCK DIAGRAM

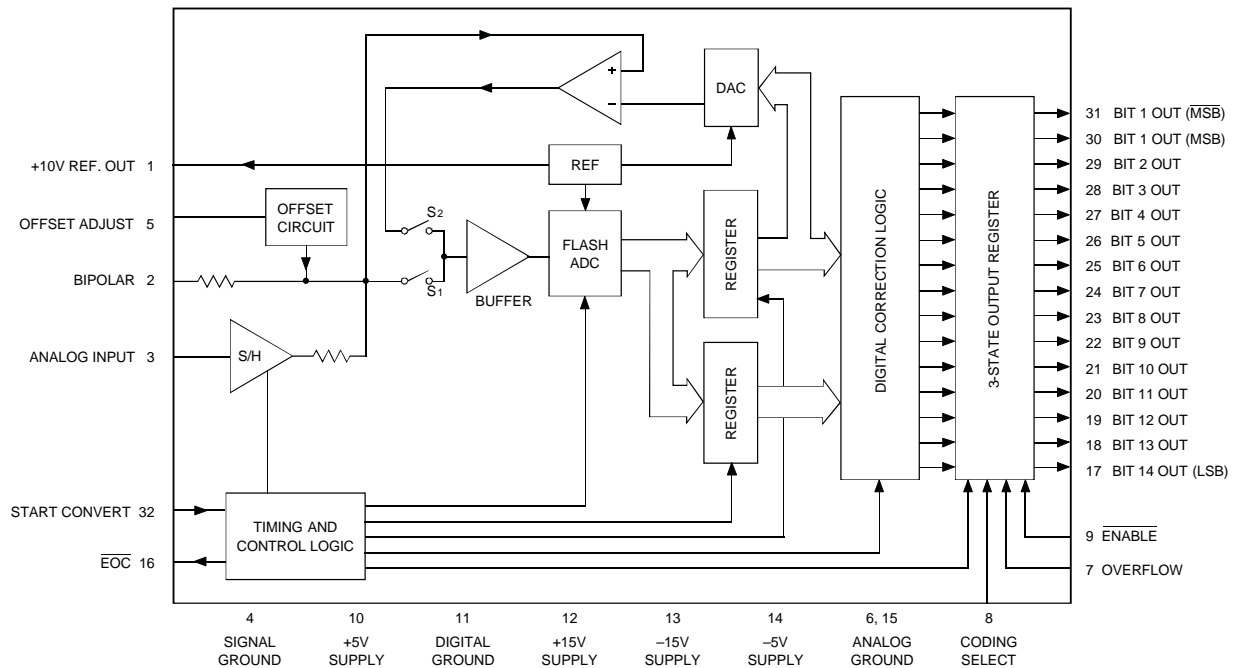

Figure 1. ADS-942A Functional Block Diagram

ABSOLUTE MAXIMUM RATINGS		
PARAMETERS	LIMITS	UNITS
+15V Supply (Pin 12)	0 to +16	Volts
-15V Supply (Pin 13)	0 to -16	Volts
+5V Supply (Pin 10)	0 to +6.0	Volts
Digital Inputs (Pin 8, 9, 32)	-0.3 to +VDD +0.3	Volts
Analog Input (Pin 3)	±25	Volts
Lead Temp. (10 seconds)	300	°C

FUNCTIONAL SPECIFICATIONS

(TA = +25°C, ±VCC = ±15V ±VDD = +5V, 2MHz sampling rate, and a minimum 7 minute warmup unless otherwise specified.)

ANALOG INPUTS	MIN.	TYP.	MAX.	UNITS
Input Voltage Range				
Unipolar	—	0 to +10	—	Volts
Bipolar	—	±5	—	Volts
Input Impedance	2.2	5	—	kΩ
Input Capacitance	—	7	15	pF
DIGITAL INPUTS				
Logic Levels				
Logic "1"	+2.0	—	—	Volts
Logic "0"	—	—	+0.5	Volts
Logic Loading "1"	—	—	+5	μA
Logic Loading "0"	—	—	-600	μA
PERFORMANCE				
Integral Non-Linearity (fin = 1MHz)				
+25°C	—	±1	±2	LSB
0 to +70°C	—	±1	±2	LSB
-40 to +100°C	—	±2	±3	LSB
Differential Non-Linearity (fin = 1MHz)				
+25°C	—	±0.5	±0.75	LSB
0 to +70°C	-0.95	±0.75	±0.95	LSB
-40 to +100°C	-1	±1	+2.5	LSB
Full Scale Absolute Accuracy				
+25°C	—	±0.1	±0.122	%FSR
0 to +70°C	—	±0.12	±0.36	%FSR
-40 to +100°C	—	±0.45	±0.85	%FSR
Unipolar Zero Error				
+25°C (see Figure 3)	—	±0.05	±0.122	%FSR
0 to +70°C	—	±0.1	±0.2	%FSR
-40 to +100°C	—	±0.2	±0.3	%FSR
Bipolar Zero Error				
+25°C (see Figure 3)	—	±0.05	±0.122	%FSR
0 to +70°C	—	±0.1	±0.2	%FSR
-40 to +100°C	—	±0.2	±0.3	%FSR
Bipolar Offset Error				
+25°C (see Figure 3)	—	±0.1	±0.2	%FSR
0 to +70°C	—	±0.12	±0.3	%FSR
-40 to +100°C	—	±0.5	±0.8	%FSR
Gain Error				
+25°C (see Figure 3)	—	±0.018	±0.122	%FSR
0 to +70°C	—	±0.12	±0.3	%FSR
-40 to +100°C	—	±0.6	±0.8	%FSR
No Missing Codes (fin = 500kHz)				
14 Bits	0 to +70°C			
13 Bits	-40 to +100°C			
Resolution	14 Bits			

OUTPUTS	MIN.	TYP.	MAX.	UNITS
Output Coding	Straight Bin./Offset Bin./Two's Comp. Comp. Bin./Comp. Offset Bin./C2C			
Logic Level				
Logic "1"	+2.4	—	—	Volts
Logic "0"	—	—	+0.4	Volts
Logic Loading "1"	—	—	-160	μA
Logic Loading "0"	—	—	+6.4	mA
Internal Reference				
Voltage, +25°C	+9.98	+10.0	+10.02	Volts
Drift	—	±13	±30	ppm/°C
External Current	—	—	5	mA

DYNAMIC PERFORMANCE				
Total Harm. Distort. (-0.5dB)				
dc to 100kHz	—	-85	—	dB
100kHz to 500kHz	—	-80	-75	dB
500kHz to 1MHz	—	-77	-70	dB
Signal-to-Noise Ratio (w/o distortion, -0.5dB)				
dc to 100kHz	74	78	—	dB
100kHz to 500kHz	73	75	—	dB
500kHz to 1MHz	—	73	—	dB
Signal-to-Noise Ratio (and distortion, -0.5dB) ①				
dc to 100kHz	73	78	—	dB
100kHz to 500kHz	72	75	—	dB
500kHz to 1MHz	—	72	—	dB
Spurious Free Dyn. Range ②				
dc to 100kHz	—	-86	-77	dB
100 to 500kHz	—	-81	-75	dB
500kHz to 1MHz	—	-78	—	dB
Two-tone IMD ③	—	85	—	dB
Input Bandwidth (-3dB)				
Small Signal (-20dB input)	—	6	—	MHz
Large Signal (-0.5dB input)	—	1.75	—	MHz
Slew Rate	—	250	—	V/μs
Aperature Delay Time	—	—	10	ns
Aperature Uncertainty	—	—	±10	ps
S/H Acquisition Time (to ±0.003%FSR)				
Sinusoidal (fin = 1MHz)	—	—	150	ns
Step input (10V)	—	250	450	ns
Conversion Rate				
Sinusoidal (fin = 1MHz)	2	—	—	MHz
Step input	1.3	—	—	MHz
Feedthrough Rejection (fin = 1MHz)	—	85	—	dB
Overvoltage Recovery, ±12V	—	1000	2000	ns
Noise	—	250	—	μVrms
POWER REQUIREMENTS				
Power Supply Ranges				
+15V Supply	+14.25	+15.0	+15.75	Volts
-15V Supply	-14.25	-15.0	-15.75	Volts
+5V Supply	+4.75	+5.0	+5.25	Volts
-5V Supply	-4.75	-5.0	-5.25	Volts
Power Supply Currents				
+15V Supply	—	+65	+87	mA
-15V Supply	—	-80	-105	mA
+5V Supply	—	+150	+185	mA
-5V Supply	—	-55	-65	mA
Power Dissipation	—	2.9	3.5	Watts
Power Supply Rejection	—	—	±0.05	%FSR/V

PHYSICAL/ENVIRONMENTAL				
Operating Temp. Range, Case				
ADS-942AMC, AMC-C	0	—	+70	°C
ADS-942AME, AM-C	-40	—	+100	°C
Storage Temperature Range				
	-65	—	+150	°C
Package Type				
	32-pin, metal-sealed, ceramic TDIP			
Weight				
	0.46 ounces (13 grams)			

Footnotes:

① Effective bits is equal to:

$$\frac{(\text{SNR} + \text{Distortion}) - 1.76 + \left[20 \log \frac{\text{Full Scale Amplitude}}{\text{Actual Input Amplitude}} \right]}{6.02}$$

② Same specification as In-Band Harmonics and Peak Harmonics.

③ Two-tone Intermodulation Distortion (IMD) conditions:
fin = 100kHz, 240kHz, fs = 2MHz, -0.5dB.

TECHNICAL NOTES

- Rated performance requires using good high-frequency circuit board layout techniques. Connect the digital and analog grounds to one point, the analog ground plane beneath the converter. Due to the inductance and resistance of the power supply return paths, return the analog and digital ground separately to the power supplies. SIGNAL GROUND (pin 4) is not internally connected to ANALOG GROUND (pins 6, 15).
- Bypass the analog and digital supplies and the +10V REF. OUT (pin 1) to ground with a 4.7µF, 25V tantalum electrolytic capacitor in parallel with a 0.1µF ceramic capacitor.
- CODING SELECT (pin 8) is compatible with CMOS/TTL logic levels for those users desiring logic control of this function. There is an internal pull-up resistor on this pin; connect to +5V or leave open for logic 1. See the Calibration Procedure for selecting an output coding.
- To enable the three-state outputs, connect $\overline{\text{ENABLE}}$ (pin 9) to a logic "0" (low). To disable, connect pin 9 to a logic "1" (high).
- OVERFLOW (pin 7) changes from low (logic "0") to high (logic "1") when the input voltage exceeds the input voltage range limits by 1LSB (610µV).

CALIBRATION PROCEDURE

- Connect the converter per Figure 3 and Table 1 for the appropriate input voltage range. Apply a pulse of 35 nanoseconds minimum to START CONVERT (pin 32) at a rate of 200kHz. This rate is chosen to reduce flicker if LEDs are used on the outputs for calibration purposes.

2. Zero Adjustments

Apply a precision voltage reference source between ANALOG INPUT (pin 3) and SIGNAL GROUND (pin 4), then adjust the reference source output per Table 2.

For unipolar, adjust the zero trimpot so that the output code flickers equally between 00 0000 0000 0000 and 00 0000 0000 0001 with CODING SELECT (pin 8) tied low (straight binary) or between 11 1111 1111 1111 and 11 1111 1111 1110 with pin 8 tied high (complementary binary).

For bipolar operation, adjust the trimpot until the code flickers equally between 10 0000 0000 0000 and 10 0000 0000 0001 with pin 8 tied low (offset binary) or between 01 1111 1111 1111 and 01 1111 1111 1110 with pin 8 tied high (complementary offset binary).

Two's complement coding requires using pin 31 (MSB). With pin 8 tied low, adjust the trimpot until the code flickers between 00 0000 0000 0000 and 00 0000 0000 0001.

- Set the output of the voltage reference used in step 2 to the value shown in Table 2.

Adjust the gain trimpot until the output code flickers equally between 11 1111 1111 1110 and 11 1111 1111 1111 with pin 8 tied low (straight binary/offset binary) or between 00 0000 0000 0000 and 00 0000 0000 0001 with pin 8 tied high (complementary binary/complementary offset binary).

Two's complement coding requires using pin 31 (MSB). With pin 8 tied low, adjust the gain trimpot until the output code flickers equally between 01 1111 1111 1110 and 01 1111 1111 1111.

- To confirm proper operation of the device, vary the precision reference voltage source to obtain the output coding listed in Table 3.

INPUT RANGE	INPUT PIN	TIE TOGETHER
0 to +10V	Pin 3	Pins 2 and 4
±5V	Pin 3	Pins 1 and 2

Table 1. Input Connections

INPUT ZERO ADJUST RANGE	GAIN ADJUST +½ LSB	FS -½ LSB
0 to +10V	+305µV	+9.999085V
±5V	+305µV	+4.999085V

Table 2. Zero and Gain Adjustments

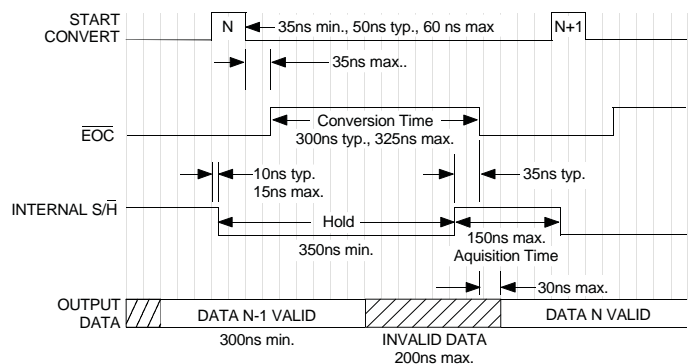

Note: Scale is approximately 25ns per division.

Figure 2. ADS-942A Timing Diagram

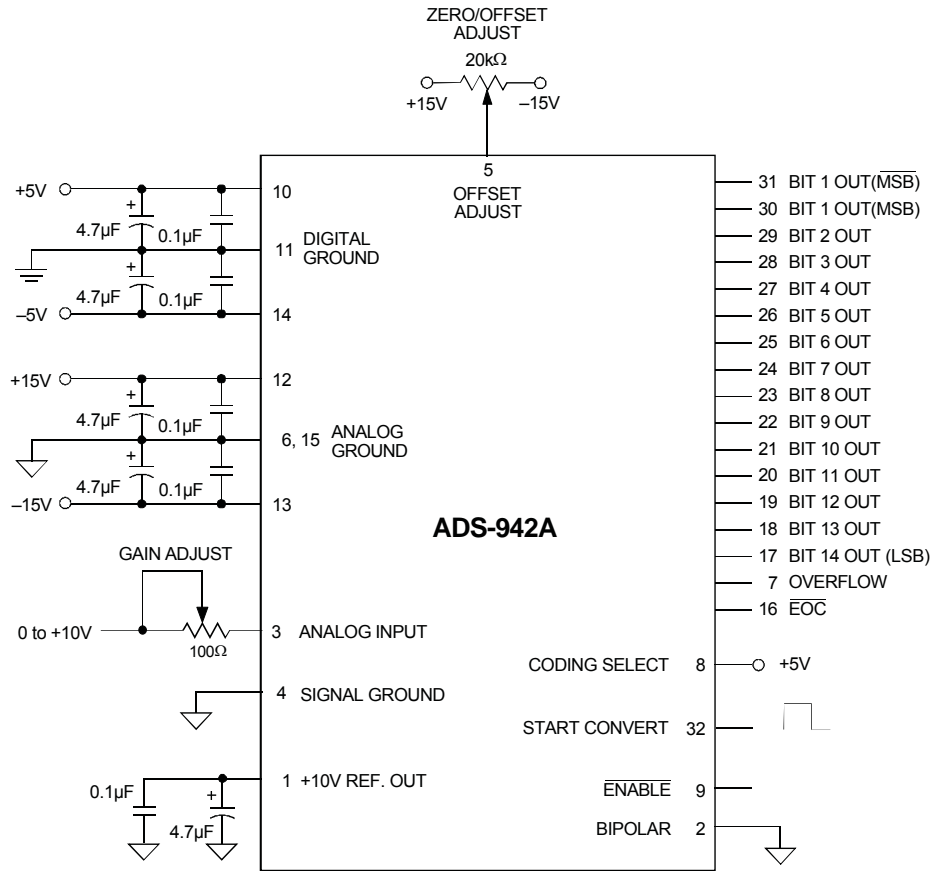

Figure 3. Typical ADS-942A Connection Diagram

Removing System Errors

Use external trim pots to remove system errors or to reduce small initial errors to zero. Use a 100Ω trim pot in series with the analog input for gain adjustment; use a fixed 50Ω resistor in its place for operation without adjustment.

Use a 20kΩ trim pot with the wiper tied to OFFSET ADJUST (pin 5) for zero/offset adjustment. Connect pin 5 to ANALOG GROUND (pin 6) for operation without zero/offset adjustment.

UNIPOLAR SCALE	INPUT RANGE 0 to +10V	STRAIGHT BINARY		COMP. BINARY		INPUT RANGE ±5V	BIPOLEAR SCALE
		MSB	LSB	MSB	LSB		
+FS - 1 LSB	+9.999390	11 1111 1111 1111	00 0000 0000 0000	01 1111 1111 1111	01 1111 1111 1111	+4.999390	+FS - 1LSB
+7/8 FS	+8.750000	11 1000 0000 0000	00 0111 1111 1111	01 1000 0000 0000	01 1000 0000 0000	+3.750000	+3/4FS
+3/4 FS	+7.500000	11 0000 0000 0000	00 1111 1111 1111	01 0000 0000 0000	01 0000 0000 0000	+2.500000	+1/2FS
+1/2 FS	+5.000000	10 0000 0000 0000	01 1111 1111 1111	00 0000 0000 0000	00 0000 0000 0000	0.000000	0
+1/4 FS	+2.500000	01 0000 0000 0000	10 1111 1111 1111	11 0000 0000 0000	11 0000 0000 0000	-2.500000	-1/2FS
+1/8 FS	+1.250000	00 1000 0000 0000	11 0111 1111 1111	10 1000 0000 0000	10 1000 0000 0000	-3.750000	-3/4FS
+1 LSB	+0.000610	00 0000 0000 0001	11 1111 1111 1110	10 0000 0000 0001	10 0000 0000 0001	-4.999390	-FS+1LSB
0	0.000000	00 0000 0000 0000	11 1111 1111 1111	10 0000 0000 0000	10 0000 0000 0000	-5.000000	-FS
		OFFSET BINARY		COMP. OFF. BIN.		TWO'S COMP.	

Table 3. Output Coding

THERMAL REQUIREMENTS

All DATEL sampling A/D converters are fully characterized and specified over operating temperature (case) ranges of 0 to +70°C and -55 to +125°C. All room-temperature (TA = +25°C) production testing is performed without the use of heat sinks or forced-air cooling. Thermal impedance figures for each device are listed in their respective specification tables.

These devices do not normally require heat sinks, however, standard precautionary design and layout procedures should be used to ensure devices do not overheat. The ground and power planes beneath the package, as well as all pcb signal runs to and from the device, should be as heavy as possible to help conduct heat away from the package.

Electrically insulating, thermally conductive "pads" may be installed underneath the package. Devices should be soldered to boards rather than "socketed," and of course, minimal air flow over the surface can greatly help reduce the package temperature.

In more severe ambient conditions, the package/junction temperature of a given device can be reduced dramatically (typically 35%) by using one of DATEL's HS Series heat sinks. See Ordering Information for the assigned part number. See page 1-183 of the DATEL Data Acquisition Components Catalog for more information on the HS Series. Request DATEL Application Note AN-8, "Heat Sinks for DIP Data Converters," or contact DATEL directly, for additional information.

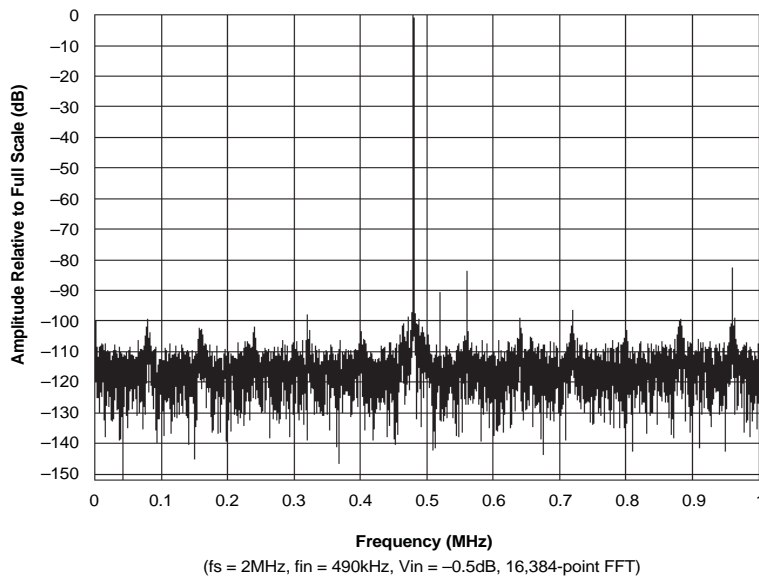
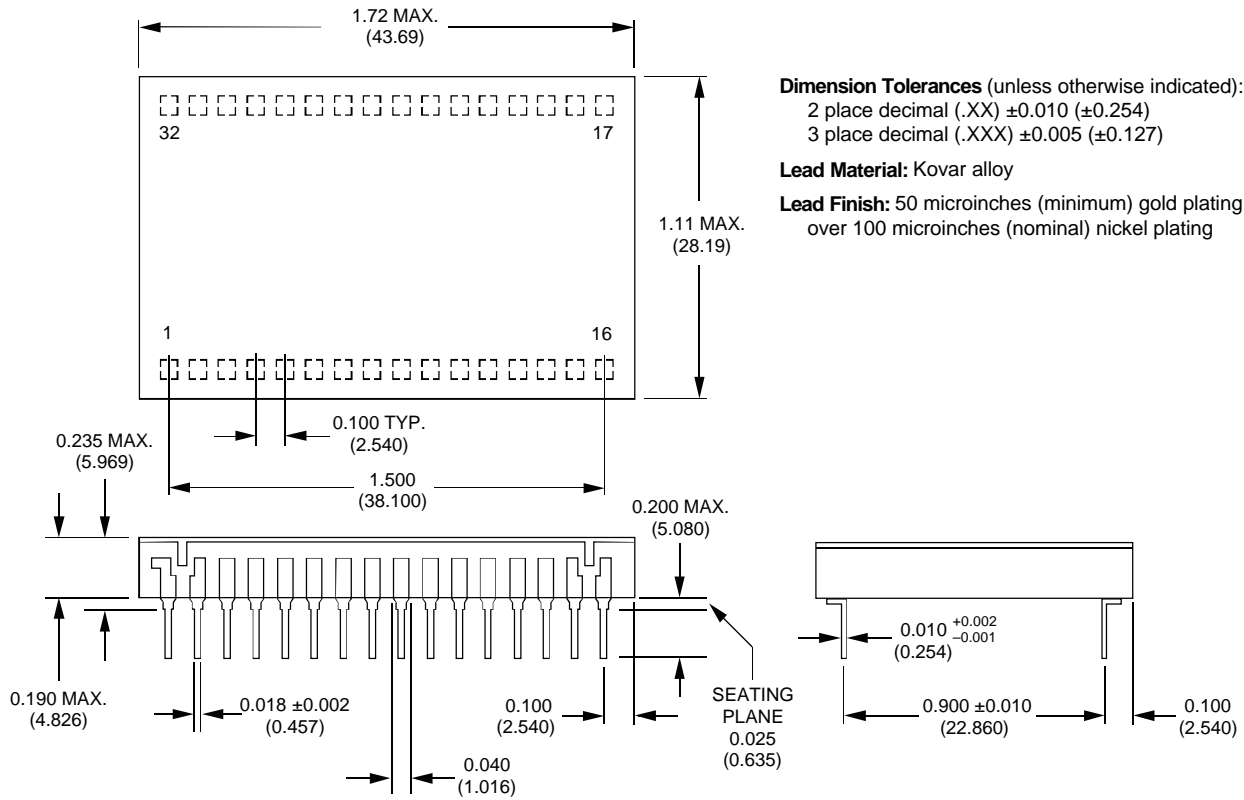

Figure 4. ADS-942A FFT Analysis

MECHANICAL DIMENSIONS INCHES (mm)



ORDERING INFORMATION

MODEL NUMBER	OPERATING TEMP. RANGE	PACKAGE	ROHS	ACCESSORIES	
ADS-942AMC	0 to +70°C	TDIP	No	ADS-EVAL4 HS-32	Evaluation Board (without ADS-942A) Heat Sink for all ADS-942A models
ADS-942AMC-C	0 to +70°C	TDIP	Yes		
ADS-942AME	-40 to +100°C	TDIP	No		
ADS-942AME-C	-40 to +100°C	TDIP	Yes		

Receptacles for PC mounting can be ordered through AMP Inc., Part # 3-331272-8 (Component Lead Socket), 32 required.