

Rad-Hard 80 V, 5 A NPN transistor

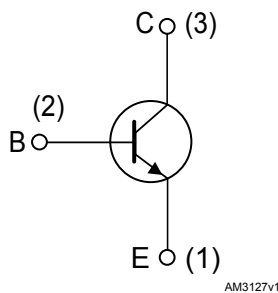
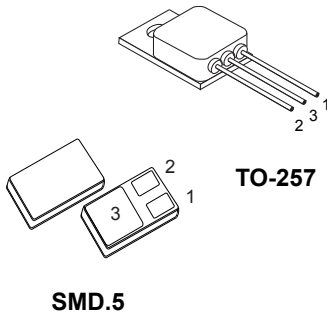

Base and Emitter are inverted for 2N5154RSRHRx and 2N5154SRHRx series. For TO-257, the case is not connected to any pin. For SMD.5, the lid is not connected to any pin.

Product status link

[2N5154HR](#)

Features

V_{CEO}	$I_C(\text{max.})$	h_{FE} at 5 V, 2.5 A	Operating temperature range
80 V	5 A	> 70	-65 °C to +200 °C

- Hermetic package
- ESCC qualified
- Up to 100 krad(Si) low dose rate

Description

The 2N5154HR is a bipolar transistor able to operate under severe environment conditions and radiation exposure. It provides high reliability performance and immunity to the total ionizing dose (TID).

Qualified as per ESCC 5203/010 specification and available in SMD.5 and TO-257 hermetic packages, it is specifically recommended for space and harsh environment applications and suitable for power suppliers, battery switch and linear bias supply circuits.

In case of discrepancies between this datasheet and the relevant agency specification, the latter takes precedence.

Product summary

Product summary				
Device	Qualification system	Agency specification	Package	Remarks
2N5154ESYHRx	ESCC	5203/010	TO-257	-
2N5154RESYHRx	ESCC	5203/010	TO-257	100 krad ESCC LDR
2N5154RSRHRx	ESCC	5203/010	SMD.5	100 krad LDR, emitter on pin 1
2N5154SHRx	ESCC	5203/010	SMD.5	Emitter on pin 1
2N5154RSRHRx	ESCC	5203/010	SMD.5	100 krad LDR, emitter on pin 1
2N5154SRHRx	ESCC	5203/010	SMD.5	Emitter on pin 2

Note: See [Table 7](#) for ordering information.

1 Electrical ratings

Table 1. Absolute maximum ratings

Symbol	Parameter	Value	Unit
V_{CBO}	Collector-base voltage ($I_E = 0$)	100	V
V_{CEO}	Collector-emitter voltage ($I_B = 0$)	80	V
V_{EBO}	Emitter-base voltage ($I_C = 0$)	6	V
I_C	Collector current	5	A
P_{TOT}	Total dissipation at $T_{amb} \leq 25\text{ °C}$ for TO-257 and SMD.5	3.3	W
	Total dissipation at $T_{case} \leq 25\text{ °C}$ for TO-257 and SMD.5	35	W
T_{OP}	Operating temperature range	-65 to 200	°C
T_J	Max. operating junction temperature	200	°C

Table 2. Thermal data

Symbol	Parameter	TO-257 and SMD.5 value	Unit
$R_{thj-case}$	Thermal resistance junction-case	5	°C/W
$R_{thj-amb}$	Thermal resistance junction-ambient	53	°C/W

2 Electrical characteristics

Table 3. Electrical characteristics ($T_{amb} = 25\text{ °C}$ unless otherwise specified)

Symbol	Parameter	Test conditions	Min.	Max.	Unit
I_{CES}	Collector cut-off current	$V_{CB} = 60\text{ V}, I_E = 0\text{ A}$		1	μA
		$V_{CB} = 60\text{ V}, I_E = 0\text{ A},$ $T_{amb} = 150\text{ °C}$		10	
I_{CEO}	Collector cut-off current	$V_{CE} = 40\text{ V}, I_B = 0\text{ A}$		50	μA
I_{EBO}	Emitter cut-off current	$V_{EB} = 5\text{ V}, I_C = 0\text{ A}$		1	μA
		$V_{EB} = 6\text{ V}, I_C = 0\text{ A}$		1	mA
$V_{(BR)CEO}^{(1)}$	Collector-emitter breakdown voltage	$I_C = 100\text{ mA}, I_B = 0\text{ A}$	80		V
$V_{CE(sat)}^{(1)}$	Collector-emitter saturation voltage	$I_C = 2.5\text{ A}, I_B = 0.25\text{ A}$		1.45	V
		$I_C = 5\text{ A}, I_B = 0.5\text{ A}$		1.5	
$V_{BE(sat)}^{(1)}$	Base-emitter saturation voltage	$I_C = 2.5\text{ A}, I_B = 0.25\text{ A}$		1.45	V
		$I_C = 5\text{ A}, I_B = 0.5\text{ A}$		2.2	
$h_{FE}^{(1)}$	DC current gain	$I_C = 50\text{ mA}, V_{CE} = 5\text{ V}$	50		
		$I_C = 2.5\text{ A}, V_{CE} = 5\text{ V}$	70	200	
		$I_C = 5\text{ A}, V_{CE} = 5\text{ V}$	40		
		$I_C = 2.5\text{ A}, V_{CE} = 5\text{ V}, T_{amb} = -55\text{ °C}$	35		
h_{fe}	AC forward current transfer ratio	$I_C = 500\text{ mA}, f = 20\text{ MHz}, V_{CE} = 5\text{ V}$	3.5		
C_{obo}	Output capacitance	$I_E = 0\text{ A}, f = 1\text{ MHz}, V_{CB} = 10\text{ V}$		250	pF
t_{on}	Turn-on time	$V_{CC} = 30\text{ V}, V_{BB} = -4\text{ V},$		0.5	μs
t_{off}	Turn-off time	$V_{in} \approx 51\text{ V}, I_C = 5\text{ A},$ $I_{B1} = -I_{B2} = 0.5\text{ A}$		1.3	μs

1. Pulsed duration = 300 μs , duty cycle $\leq 2\%$

3 Electrical characteristics (curves)

Figure 1. h_{FE} at $V_{CE} = 5\text{ V}$

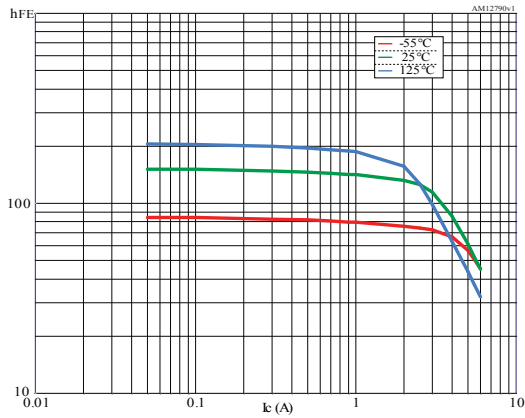

Figure 2. $V_{CE(sat)}$ at $h_{FE} = 10$

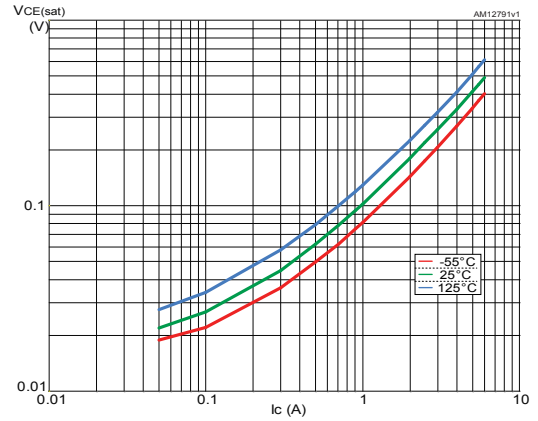

Figure 3. $V_{BE(sat)}$ at $h_{FE} = 10$

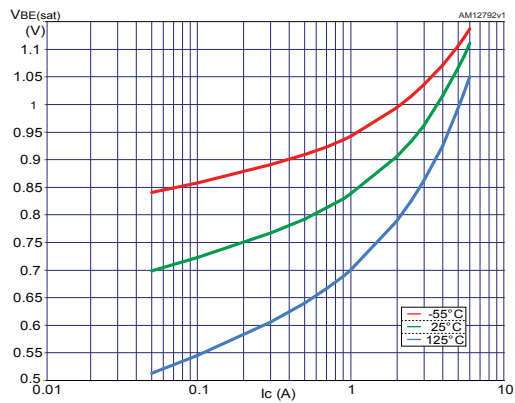
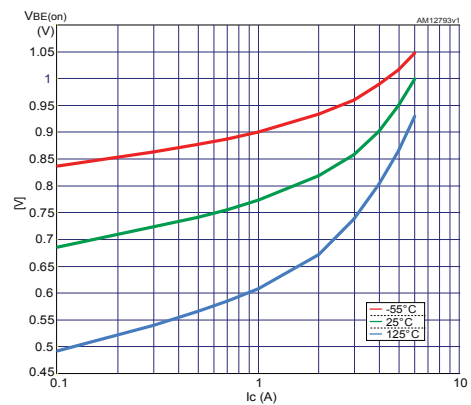
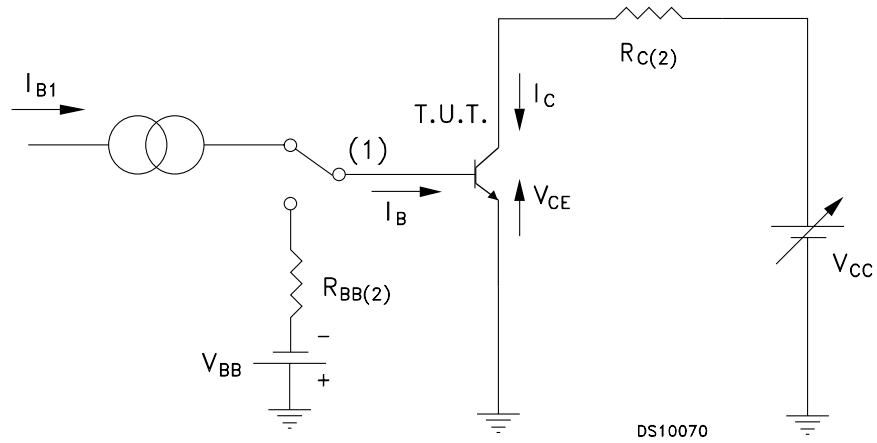

Figure 4. $V_{BE(on)}$ at $V_{CE} = 5\text{ V}$



3.1 Test circuits

Figure 5. ESCC resistive load switching test circuit



Note: (1) Fast electronic switch

Note: (2) Non-inductive resistor

4 Radiation hardness assurance

This products is guaranteed in radiation as per ESCC 22900 and in compliance with ESCC 5203/010 specification.

Each lot is tested in radiation according to the following procedure:

- Radiation condition of 0.1 rad (Si)/s
- Test of 11 samples by wafer, 5 biased at 80% of $V_{(BR)CEO}$, 5 unbiased and for reference
- Acceptance criteria of each wafer at 100 krad if all 10 samples comply with the post radiation electrical characteristics as per Table 4.

Table 4. ESCC 5203/010 post radiation electrical characteristics ($T_{amb} = 25\text{ °C}$ unless otherwise specified)

Symbol	Parameter	Test conditions	Min.	Max.	Unit
I_{CES}	Collector cut-off current	$V_{CB} = 60\text{ V}, I_E = 0\text{ A}$		1	μA
I_{CEO}	Collector cut-off current	$V_{CE} = 40\text{ V}, I_B = 0\text{ A}$		50	μA
I_{EBO}	Emitter cut-off current	$V_{EB} = 5\text{ V}, I_C = 0\text{ A}$		1	μA
		$V_{EB} = 6\text{ V}, I_C = 0\text{ A}$		1	mA
$V_{(BR)CEO}^{(1)}$	Collector-emitter breakdown voltage	$I_C = 100\text{ mA}, I_B = 0\text{ A}$	80		V
$V_{CE(sat)}^{(1)}$	Collector-emitter saturation voltage	$I_C = 2.5\text{ A}, I_B = 0.25\text{ A}$		1.45	V
		$I_C = 5\text{ A}, I_B = 0.5\text{ A}$		1.5	
$V_{BE(sat)}^{(1)}$	Base-emitter saturation voltage	$I_C = 2.5\text{ A}, I_B = 0.25\text{ A}$		1.45	V
		$I_C = 5\text{ A}, I_B = 0.5\text{ A}$		2.2	
$[h_{FE}]^{(1)}$	Post irradiation gain calculation ⁽²⁾	$I_C = 50\text{ mA}, V_{CE} = 5\text{ V}$	[25]		
		$I_C = 2.5\text{ A}, V_{CE} = 5\text{ V}$	[35]	200	
		$I_C = 5\text{ A}, V_{CE} = 5\text{ V}$	[20]		

1. Pulsed duration = 300 μs , duty cycle $\leq 2\%$

2. $[h_{FE}]$ calculated according to method 1019 of MIL-STD-750.

5 Package information

In order to meet environmental requirements, ST offers these devices in different grades of **ECOPACK** packages, depending on their level of environmental compliance. ECOPACK specifications, grade definitions and product status are available at: www.st.com. ECOPACK is an ST trademark.

5.1 TO-257 package information

Figure 6. TO-257 package outline

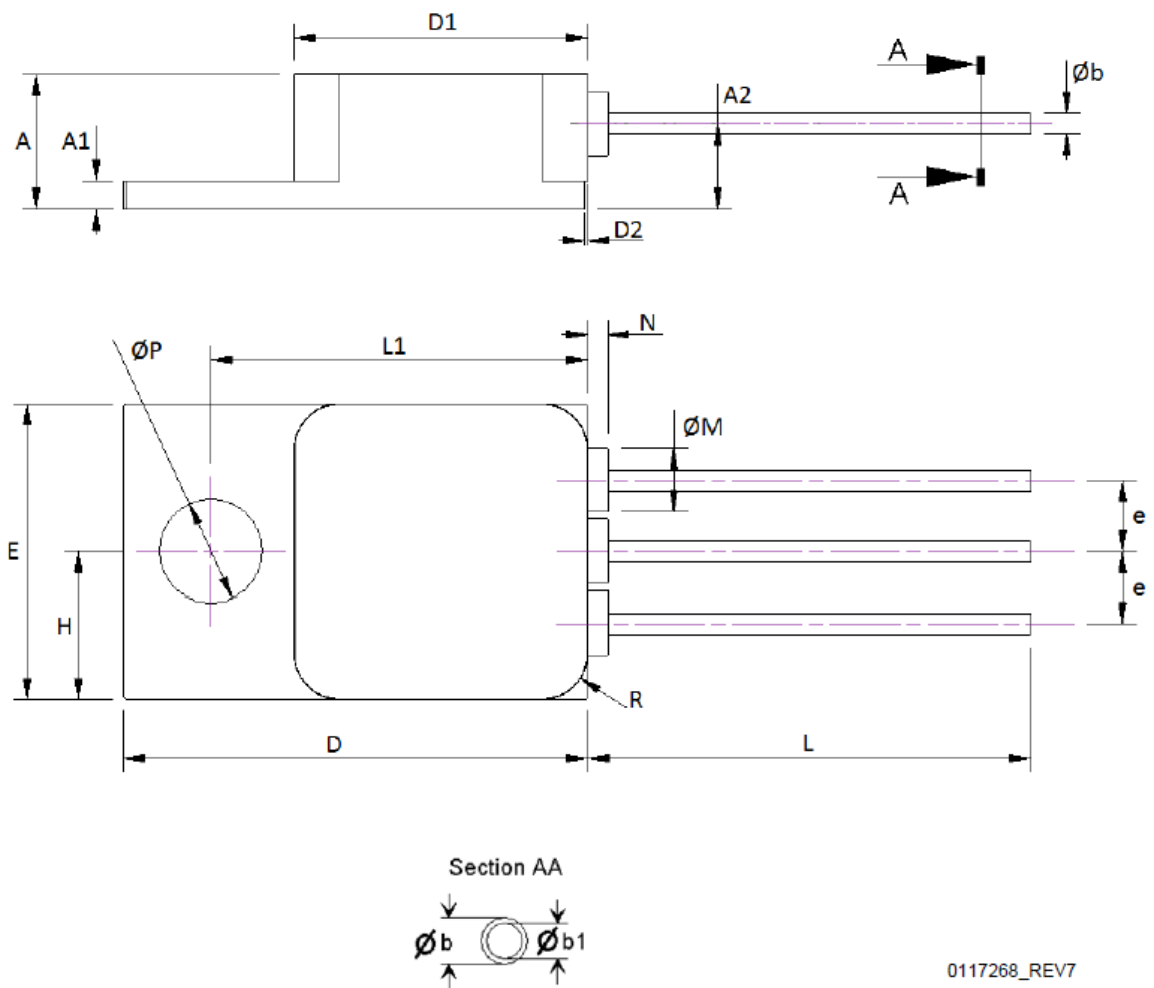

0117268_REV7

Table 5. TO-257 package mechanical data

Dim.	mm		
	Min.	Typ.	Max.
A	4.83	4.95	5.08
A1	0.89	1.02	1.14
A2	2.91	3.05	3.18
b	0.64	-	1.02
b1	0.64	0.76	0.89
D	16.51	16.64	16.76
D1	10.41	10.54	10.67
D2	-	-	0.97
e	2.41	2.54	2.67
E	10.41	10.54	10.67
H	5.13	5.25	5.38
L	15.24	15.88	16.51
L1	13.39	13.51	13.64
M	2.16	2.29	2.41
N	-	-	0.71
P	3.56	3.68	3.81
R	-	1.65	-

Note: The case is not connected to any pin.

5.2 SMD.5 package information

Figure 7. SMD.5 package outline

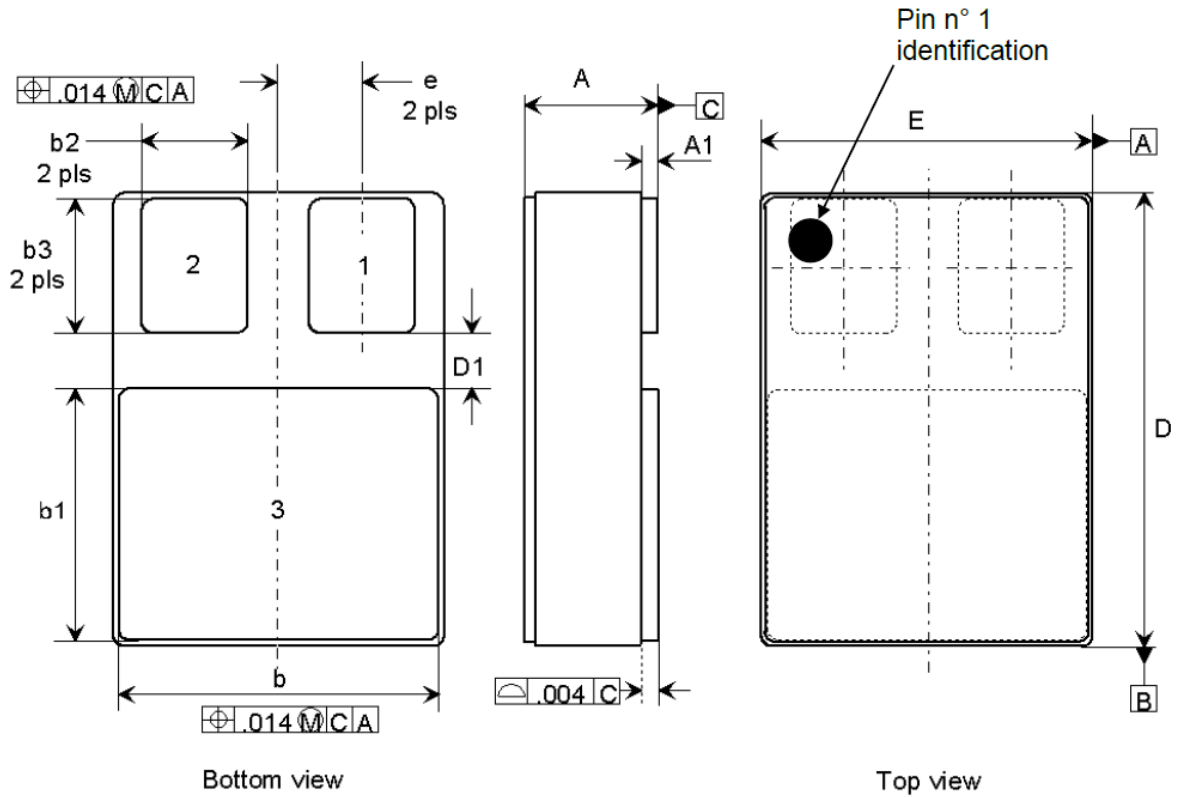

7386434_REV7

Table 6. SMD.5 package mechanical data

Dim.	mm		
	Min.	Typ.	Max.
A	2.84		3.30
A1	0.25	0.38	0.51
b	7.13	7.26	7.39
b1	5.58	5.72	5.84
b2	2.28	2.41	2.54
b3	2.92	3.05	3.18
D	10.03	10.16	10.28
D1	0.76		
E	7.39	7.52	7.64
e		1.91	

Note:

Pad 1: emitter

Pad 2: base

Pad 3: collector

- base and emitter are inverted for 2N5154RSRHRx and 2N5154SRHRx series
- the lid is not connected to any pin

6 Ordering information

Table 7. Ordering information

Part number	Agency specification	Quality level	Radiation level	Pin-out	Package	Weight	Lead finish	Marking ⁽¹⁾	Packing
2N5154ESY1	-	EM ⁽²⁾	-	-	TO-257	5 g	Gold	2N5154ESY1 + BeO	Strip pack
2N5154ESYHRG	5203/010/04	ESCC	-	-			Solder dip	520301004 + BeO	
2N5154ESYHRT	5203/010/05		-	-			Gold	520301005 + BeO	
2N5154RESYHRG	5203/010/04R		100 krad	-			Solder dip	520301004R + BeO	
2N5154RESYHRT	5203/010/05R		100 krad	-			Gold	520301005R + BeO	
2N5154S1	-		EM ⁽²⁾	-	Emitter on pin 1	SMD.5	1 g	Gold	2N5154S1
2N5154RSHRG	5203/010/06R	ESCC	100 krad	Emitter on pin 1	Solder dip			520301006R	
2N5154RSHRT	5203/010/09R	ESCC	100 krad	Emitter on pin 1	Gold			520301009R	
2N5154RSHRTW	5203/010/09R	ESCC	100 krad	Emitter on pin 1	Solder dip			520301009R	
2N5154RSHRGW	5203/010/06R	ESCC	100 krad	Emitter on pin 1	Gold			520301006R	
2N5154SHRG	5203/010/06	ESCC	-	Emitter on pin 1	Solder dip			520301006	
2N5154SHRT	5203/010/09	ESCC	-	Emitter on pin 1	Gold			520301009	
2N5154SHRTW	5203/010/09	ESCC	-	Emitter on pin 1	Solder dip			520301009	
2N5154SHRGW	5203/010/06	ESCC	-	Emitter on pin 1	Gold			520301006	
2N5154SR1	-	EM ⁽²⁾	-	Emitter on pin 2	Solder dip			2N5154SR1	
2N5154RSRHRG	5203/010/07R	ESCC	100 krad	Emitter on pin 2	Gold			520301007R	
2N5154RSRHRT	5203/010/10R	ESCC	100 krad	Emitter on pin 2	Solder dip			520301010R	
2N5154RSRHRTW	5203/010/10R	ESCC	100 krad	Emitter on pin 2	Gold			520301010R	
2N5154RSRHRGW	5203/010/07R	ESCC	100 krad	Emitter on pin 2	Solder dip			520301007R	
2N5154SRHRG	5203/010/07	ESCC	-	Emitter on pin 2	Gold			520301007	
2N5154SRHRT	5203/010/10	ESCC	-	Emitter on pin 2	Solder dip			520301010	
2N5154SRHRTW	5203/010/10	ESCC	-	Emitter on pin 2	Gold			520301010	
2N5154SRHRGW	5203/010/07	ESCC	-	Emitter on pin 2	Solder dip			520301007	

1. Specific marking only. The full marking includes in addition: For the Engineering Models: ST logo, date code; country of origin (FR). For ESCC flight parts: ST logo, date code, country of origin (FR), ESA logo, serial number of the part within the assembly lot.

2. EM: Engineering model

Contact ST sales office for information about specific conditions for products in die form.



7 Other information

Table 8. Traceability and documentation

Screening type	Date codes ⁽¹⁾	Radiation level	Documentation
Engineering model	3yywwN	-	Certificate of conformance.
Flight model	yywwN	100 krad	Certificate of conformance. ESCC qualification maintenance lot reference. Radiation verification test (RVT) report at 25 / 50 / 70 / 100 krad at 0.1 rad/s.

1. yy = year, ww = week number, N = lot index in the week.

Revision history

Table 9. Document revision history

Date	Version	Changes
08-Jan-2009	1	Initial release.
08-Jan-2010	2	Modified Table 1: Device summary.
22-Jul-2011	3	Updated marking for the order code 2N5154ESYHRB in Table 1: Device summary.
12-Sep-2012	4	Added: Section 2.1: Electrical characteristics (curves) on page 5.
29-Jan-2014	5	Added Section 3: Radiation hardness assurance and Section 5: Ordering information. Updated Table 1: Device summary.
08-Apr-2014	6	Updated Table 1: Device summary and Table 10: Order codes. Updated Section 4: Package mechanical data. Added Figure 2.: Safe operating area. Minor text changes.
29-Jan-2016	7	Updated Figure 2.: Safe operating area. Minor text changes.
05-Apr-2016	8	Added part number 2N5154RSRHRG. Document updated accordingly. Updated Section 4: Package information.
02-May-2016	9	Updated package silhouette, Figure 1: Internal schematic diagram and Table 1: Device summary in cover page. Updated Section 4: Package information and Section 5: Ordering information. Inserted Section 6: Shipping details. Minor text changes.
28-Oct-2016	10	Added Table 6: Product mass summary.
27-Jul-2020	11	Removed TO-39 package information. Updated Section 5.1 TO-257 package information, Section 5.2 SMD.5 package information and Ordering information. Minor text changes.
25-Mar-2021	12	Updated Table 1, Figure 1 and Table 7.
04-Oct-2021	13	Updated Table 7 and Description.
09-Jan-2023	14	Updated Table 7.

IMPORTANT NOTICE – READ CAREFULLY

STMicroelectronics NV and its subsidiaries (“ST”) reserve the right to make changes, corrections, enhancements, modifications, and improvements to ST products and/or to this document at any time without notice. Purchasers should obtain the latest relevant information on ST products before placing orders. ST products are sold pursuant to ST’s terms and conditions of sale in place at the time of order acknowledgment.

Purchasers are solely responsible for the choice, selection, and use of ST products and ST assumes no liability for application assistance or the design of purchasers’ products.

No license, express or implied, to any intellectual property right is granted by ST herein.

Resale of ST products with provisions different from the information set forth herein shall void any warranty granted by ST for such product.

ST and the ST logo are trademarks of ST. For additional information about ST trademarks, refer to www.st.com/trademarks. All other product or service names are the property of their respective owners.

Information in this document supersedes and replaces information previously supplied in any prior versions of this document.

© 2023 STMicroelectronics – All rights reserved