

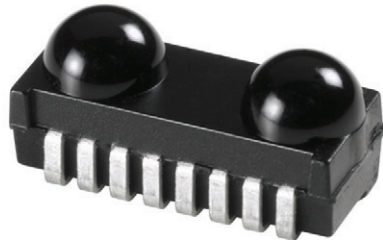

Infrared Transceiver Module (SIR, 115.2 kbit/s) for IrDA® Applications



DESCRIPTION

TFDU4101 is an infrared transceiver that supports data rates up to 115 kbit/s per the IrDA standard. The link distance is up to 1 meter. The transceiver includes a PIN photodiode, an infrared emitter, and a low-power control IC. These components have not been qualified according to automotive specifications.

FEATURES

- Compliant to the IrDA physical layer specification
- Standard IrDA link distance of 1 m
- Low power consumption
- Less than 1 μ A in shutdown mode
- Material categorization: for definitions of compliance please see www.vishay.com/doc?99912



APPLICATIONS

- Short-distance wireless communication and data transfer
- Use in environments where RF is problematic

LINKS TO ADDITIONAL RESOURCES



DESIGN SUPPORT TOOLS

- [3D model](#)
- [Window size calculator](#)
- [Symbols and terminology](#)
- [IRDC protocol](#)
- [Reference layouts and circuit diagrams](#)

FUNCTIONAL BLOCK DIAGRAM

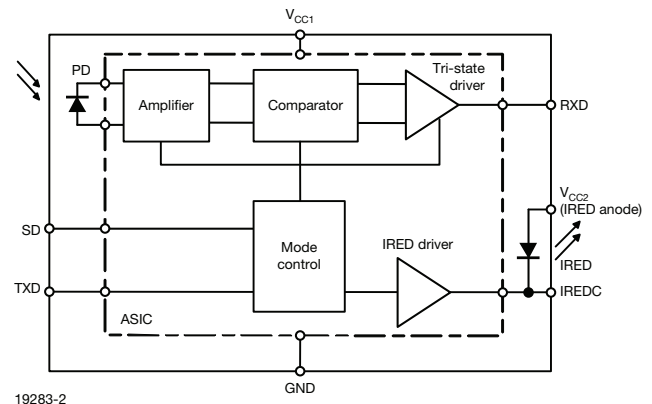



| PRODUCT SUMMARY | | | | | |
|-----------------|--------------------|-------------------------------------|-------------------|-----------------------|--------------------------|
| PART NUMBER | DATA RATE (kbit/s) | DIMENSIONS H x L x W (mm x mm x mm) | LINK DISTANCE (m) | OPERATING VOLTAGE (V) | IDLE SUPPLY CURRENT (mA) |
| TFDU4101 | 115.2 | 4 x 9.7 x 4.7 | 0 to ≥ 1 | 2.4 to 5.5 | 0.07 |

| PARTS TABLE | | |
|--------------|---|----------|
| PART | DESCRIPTION | QTY/REEL |
| TFDU4101-TR3 | Oriented in carrier tape for side view surface mounting | 1000 pcs |
| TFDU4101-TT3 | Oriented in carrier tape for top view surface mounting | 1000 pcs |

| PIN DESCRIPTION | | | | |
|-----------------|--------------------------------|--|-----|--------|
| PIN NUMBER | SYMBOL | DESCRIPTION | I/O | ACTIVE |
| 1 | V _{CC2} IRED anode | IRED anode to be externally connected to V _{CC2} . An external resistor is only necessary for controlling the IRED current when a current reduction below 300 mA is intended to operate in IrDA low power mode. This pin is allowed to be supplied from an uncontrolled power supply separated from the controlled V _{CC1} - supply. | | |
| 2 | IRED cathode | IRED cathode, internally connected to driver transistor | | |
| 3 | TXD | This Schmitt-Trigger input is used to transmit serial data when SD is low. An on-chip protection circuit disables the LED driver if the TXD pin is asserted for longer than 50 μs (max. 300 μs). | I | High |
| 4 | RXD | Received data output, push-pull CMOS driver output capable of driving standard CMOS or TTL loads. During transmission the RXD output is active (echo-on). No external pull-up or pull-down resistor is required. Floating with a weak pull-up of 500 kΩ (typ.) in shutdown mode. | O | Low |
| 5 | SD | Shutdown | I | High |
| 6 | V _{CC1} | Supply voltage | | |
| 7 | NC | No internal connection | I | |
| 8 | GND | Ground | | |

PINOUT

TFDU4101
Weigh 212 mg

"U" Option Baby Face (universal)

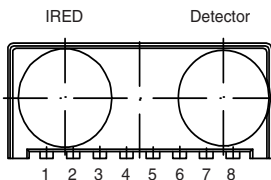

17087



| ABSOLUTE MAXIMUM RATINGS | | | | | | |
|--|---|----------------|-------------|------|-----------------|------|
| PARAMETER | TEST CONDITIONS | SYMBOL | MIN. | TYP. | MAX. | UNIT |
| Supply voltage range, transceiver | $-0.3\text{ V} < V_{CC2} < 6\text{ V}$ | V_{CC1} | -0.5 | - | +6 | V |
| Supply voltage range, transmitter | $-0.5\text{ V} < V_{CC1} < 6\text{ V}$ | V_{CC2} | -0.5 | - | +6 | V |
| RXD output voltage | $-0.5\text{ V} < V_{CC1} < 6\text{ V}$ | V_{RXD} | -0.5 | - | $V_{CC1} + 0.5$ | V |
| Voltage at all inputs | Note: $V_{in} \geq V_{CC1}$ is allowed | V_{IN} | -0.5 | - | +6 | V |
| Input current | For all pins, except IRED anode pin | | - | - | 10 | mA |
| Output sinking current | | | - | - | 25 | mA |
| Power dissipation | | P_D | - | - | 250 | mW |
| Junction temperature | | T_J | - | - | 125 | °C |
| Ambient temperature range (operating) | | T_{amb} | -25 | - | +85 | °C |
| Storage temperature range | | T_{stg} | -25 | - | +85 | °C |
| Soldering temperature | See recommended solder profile | | - | - | 260 | °C |
| Average output current, pin 1 | | $I_{IRED(DC)}$ | - | - | 85 | mA |
| Repetitive pulsed output current, pin 1 to pin 2 | $t < 90\ \mu\text{s}$, $t_{on} < 20\ \%$ | $I_{IRED(RP)}$ | - | - | 430 | mA |
| ESD protection | JESD22-A114 | V_{ESD} | 2 | - | - | kV |
| Latchup | JESD78 | | $ \pm 100 $ | - | - | mA |
| Thermal resistance junction-to-ambient | JESD51 | R_{thJA} | - | 300 | - | K/W |

Note

- Reference point ground (pin 8) unless otherwise noted.
Typical values are for DESIGN AID ONLY, not guaranteed nor subject to production testing

| EYE SAFETY INFORMATION | |
|---|----------------|
| STANDARD | CLASSIFICATION |
| IEC/EN 60825-1 (2007-03), DIN EN 60825-1 (2008-05) "SAFETY OF LASER PRODUCTS - Part 1: equipment classification and requirements", simplified method | Class 1 |
| IEC 62471 (2006), CIE S009 (2002) "Photobiological Safety of Lamps and Lamp Systems" | Exempt |
| DIRECTIVE 2006/25/EC OF THE EUROPEAN PARLIAMENT AND OF THE COUNCIL of 5 th April 2006 on the minimum health and safety requirements regarding the exposure of workers to risks arising from physical agents (artificial optical radiation) (19 th individual directive within the meaning of article 16(1) of directive 89/391/EEC) | Exempt |

Note

- Vishay transceivers operating inside the absolute maximum ratings are classified as eye safe according the above table



| ELECTRICAL CHARACTERISTICS ($T_{amb} = 25\text{ }^{\circ}\text{C}$, $V_{CC1} = V_{CC2} = 2.4\text{ V to } 5.5\text{ V}$ unless otherwise noted) | | | | | | |
|--|---|-----------|----------------------|----------------------|-----------------------|------------------|
| PARAMETER | TEST CONDITIONS | SYMBOL | MIN. | TYP. | MAX. | UNIT |
| TRANSCEIVER | | | | | | |
| Supply voltage | | V_{CC1} | 2.4 | - | 5.5 | V |
| Data rates | | | 9.6 | - | 115.2 | kbit/s |
| Idle supply current at V_{CC1} (receive mode, no signal) | SD = low, $T_{amb} = -25\text{ }^{\circ}\text{C to } +85\text{ }^{\circ}\text{C}$ independent of ambient light, $V_{CC1} = V_{CC2} = 2.4\text{ V to } 5.5\text{ V}$ | I_{CC1} | 40 | 70 | 110 | μA |
| Average dynamic supply current, transmitting | $I_{RED} = 300\text{ mA}$, 20 % duty cycle | I_{CC1} | - | 0.6 | 2 | mA |
| Standby (SD) ⁽¹⁾ supply current | SD = high, $T_{amb} = -25\text{ }^{\circ}\text{C to } +85\text{ }^{\circ}\text{C}$ independent of ambient light | I_{SD} | - | 0.01 | 1 | μA |
| RXD to V_{CC1} impedance | SD = high | R_{RXD} | 400 | 500 | 600 | $\text{k}\Omega$ |
| Input voltage low (TXD, SD) | | V_{ILo} | -0.3 | - | 0.4 | V |
| Input voltage high (SD) | For compliance with ISD spec. | V_{IHl} | $V_{CC1} - 0.3$ | - | 6 | V |
| Input voltage high (TXD) | | V_{IHl} | $V_{CC1} - 0.5$ | - | 6 | V |
| Timing logic decision level | | | - | $0.5 \times V_{CC1}$ | - | |
| Input leakage current low | $V_{ILo} \leq 0.3\text{ V}$ | I_{ILo} | - | 0.01 | 10 | μA |
| Input leakage current high | $V_{IHl} \geq V_{CC1} - 0.3\text{ V}$ | I_{IHl} | - | 0.01 | 10 | μA |
| Input capacitance (TXD, SD) | | C_{IN} | - | - | 5 | pF |
| Output voltage low, RXD | $C_{load} = 8\text{ pF}$, $I_{OLo} \leq +500\text{ }\mu\text{A} $ | V_{OLo} | - | - | $0.15 \times V_{CC1}$ | V |
| Output voltage high, RXD | $I_{OH} = 200\text{ }\mu\text{A}$ | V_{OHl} | $0.8 \times V_{CC1}$ | - | - | V |

Notes

- Typical values are for DESIGN AID ONLY, not guaranteed nor subject to production testing
- ⁽¹⁾ SD mode becomes active when SD is set high for more than 0.2 ms. In SD mode the detector is disabled and the output disconnected



| OPTOELECTRONIC CHARACTERISTICS (T _{amb} = 25 °C, V _{CC1} = V _{CC2} = 2.4 V to 5.5 V unless otherwise noted) | | | | | | |
|--|--|---------------------------------------|-------------------------|------|-------------------------|--|
| PARAMETER | TEST CONDITIONS | SYMBOL | MIN. | TYP. | MAX. | UNIT |
| RECEIVER | | | | | | |
| Minimum irradiance E _e in angular range ⁽²⁾ | 9.6 kbit/s to 115.2 kbit/s, λ = 850 nm to 900 nm; α = 0°, 15° | E _e | - | 15 | 40 | mW/m ² |
| Maximum irradiance E _e In Angular Range ⁽³⁾ | λ = 850 nm to 900 nm | E _e | 2 | 5 | - | kW/m ² |
| Maximum no detection irradiance ⁽¹⁾ | λ = 850 nm to 900 nm, t _r , t _f < 40 ns, t _{po} = 1.6 μs at f = 115 kHz, no output signal allowed | E _e | 4 (0.4) | - | - | mW/m ² (μW/cm ²) |
| Rise time of output signal | 10 % to 90 %, C _L = 8 pF | t _{r(RXD)} | 10 | 30 | 80 | ns |
| Fall time of output signal | 90 % to 10 %, C _L = 8 pF | t _{f(RXD)} | 10 | 30 | 80 | ns |
| RXD pulse width of output signal | Input pulse length > 1.2 μs | t _{PW} | 1.7 | 2.2 | 3 | μs |
| Stochastic jitter, leading edge | Input irradiance = 100 mW/m ² , ≤ 115.2 kbit/s | | - | - | 350 | ns |
| Standby / shutdown delay, receiver startup time | After shutdown active or power-on | | - | 100 | 500 | μs |
| Latency | | t _L | - | 50 | 150 | μs |
| TRANSMITTER | | | | | | |
| IRED operating current limitation | No external resistor for current limitation ⁽⁴⁾ | I _D | 200 | 300 | 430 | mA |
| Forward voltage of built-in IRED | I _f = 300 mA | V _f | 1.4 | 1.8 | 1.9 | V |
| Output leakage IRED current | TXD = 0 V, 0 < V _{CC1} < 5.5 V | I _{IRED} | -1 | 0.01 | 1 | μA |
| Output radiant intensity | α = 0°, 15°, TXD = high, SD = low | I _e | 50 | 150 | 400 | mW/sr |
| | V _{CC1} = 5 V, α = 0°, 15°, TXD = low or SD = high (receiver is inactive as long as SD = high) | I _e | - | - | 0.04 | mW/sr |
| Output radiant intensity, angle of half intensity | | α | - | ± 30 | - | ° |
| Peak - emission wavelength ⁽⁵⁾ | | λ _p | 870 | - | 910 | nm |
| Spectral bandwidth | | Δλ | - | 45 | - | nm |
| TRANSMITTER | | | | | | |
| Optical rise time, fall time | | t _{ropt} , t _{fopt} | 10 | 50 | 100 | ns |
| Optical output pulse duration | Input pulse width 1.6 < t _{TXD} < 23 μs | t _{opt} | t _{TXD} - 0.15 | | t _{TXD} + 0.15 | μs |
| | Input pulse width t _{TXD} ≥ 23 μs | t _{opt} | 23 | 50 | 100 | μs |
| Optical overshoot | | | | | 25 | % |

Notes

- Typical values are for DESIGN AID ONLY, not guaranteed nor subject to production testing
- ⁽¹⁾ Equivalent to IrDA background light and electromagnetic field test: fluorescent lighting immunity
- ⁽²⁾ IrDA sensitivity definition: minimum irradiance E_e in angular range, power per unit area. The receiver must meet the BER specification while the source is operating at the minimum intensity in angular range into the minimum half-angular range at the maximum link length
- ⁽³⁾ Maximum irradiance E_e in angular range, power per unit area. The optical delivered to the detector by a source operating at the maximum intensity in angular range at minimum link length must not cause receiver overdrive distortion and possible related link errors. If placed at the active output interface reference plane of the transmitter, the receiver must meet its bit error ratio (BER). For more definitions see the document "Symbols and Terminology" on the Vishay website
- ⁽⁴⁾ Using an external current limiting resistor is allowed and recommended to reduce IRED intensity and operating current when current reduction is intended to operate at the IrDA low power conditions. E.g. for V_{CC2} = 3.3 V a current limiting resistor of R_S = 56 Ω will allow a power minimized operation at IrDA low power conditions
- ⁽⁵⁾ Due to this wavelength restriction compared to the IrDA spec of 850 nm to 900 nm the transmitter is able to operate as source for the standard remote control applications with codes as e.g. Phillips RC5/RC6® or RECS 80



RECOMMENDED CIRCUIT DIAGRAM

Operated with a clean low impedance power supply the TFDU4101 needs no additional external components. However, depending on the entire system design and board layout, additional components may be required (see figure 1). That is especially the case when separate power supplies are used for bench tests. When using compact wiring and regulated supplies as e. g. in phone applications in most cases no external components are necessary.

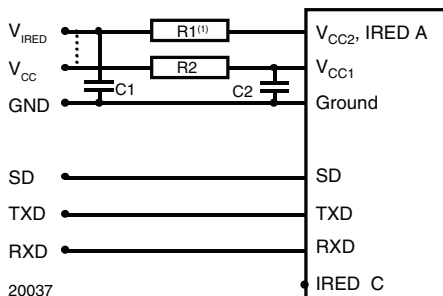

Fig. 1 - Recommended Test Circuit

Note

(1) R1 is optional when reduced intensity is used

The capacitor C1 is buffering the supply voltage and eliminates the inductance of the power supply line. This one should be a Tantalum or other fast capacitor to guarantee the fast rise time of the IRED current. The resistor R1 is the current limiting resistor, which may be used to reduce the operating current to levels below the specified controlled values for saving battery power.

A resistor R1 of 22 Ω is recommended to stay below the intensity limitation of the IrDA specification at the emission angle of ± 15° ($I_e < 40 \text{ mW/sr}$).

Vishay’s transceivers integrate a sensitive receiver and a built-in power driver. The combination of both needs a careful circuit board layout. The use of thin, long, resistive and inductive wiring should be avoided. The shutdown input must be grounded for normal operation, also when the shutdown function is not used. The inputs (TXD, SD) and the output RXD should be directly connected (DC-coupled) to the I/O circuit. The capacitor C2 combined with the resistor R2 is the low pass filter for smoothing the supply voltage. R2, C1 and C2 are optional and dependent on the quality of the supply voltages V_{CC1} and injected noise. An unstable power supply with dropping voltage during transmission may reduce the sensitivity (and transmission range) of the transceiver.

The placement of these parts is critical. It is strongly recommended to position C2 as close as possible to the transceiver power supply pins.

When extended wiring is used (bench tests!) the inductance of the power supply can cause dynamically a voltage drop at V_{CC2} . Often some power supplies are not able to follow the fast current rise time. In that case another 4.7 μF (type, see table under C1) at V_{CC2} will be helpful.

Under extreme EMI conditions as placing an RF-transmitter antenna on top of the transceiver, we recommend to protect all inputs by a low-pass filter, as a minimum a 12 pF capacitor, especially at the RXD port.

| TABLE 1 - RECOMMENDED TESTS AND APPLICATION CIRCUIT COMPONENTS | |
|--|-----------------------------------|
| COMPONENT | RECOMMENDED VALUE |
| C1 | 4.7 μF, 16 V |
| C2 | 0.1 μF, ceramic |
| R1 | Depends on current to be adjusted |
| R2 | 47 Ω |

Fig. 2 shows an example of a typical application with a separate supply voltage V_S and using the transceiver with the IRED anode connected to the unregulated battery V_{batt} . This method reduces the peak load of the regulated power supply and saves therefore costs. Alternatively all supplies can also be tied to only one voltage source. R1 and C1 are not used in this case and are depending on the circuit design in most cases not necessary.

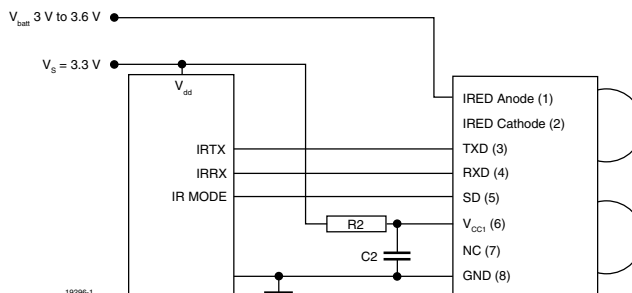

Fig. 2 - Typical Application Circuit



I/O AND SOFTWARE

In the description, already different I/Os are mentioned. Different combinations are tested and the function verified with the special drivers available from the I/O suppliers. In special cases refer to the I/O manual, the Vishay application notes, or contact directly Vishay Sales, Marketing or Application.

For operating at RS232 ports we recommend to use an encoder / decoder-module.

Note

- TFDU4101 echoes the TXD signal at the RXD output during transmission. For communication this signal is to be correctly ignored by the controller or the software. The echo signal is implemented for test purposes in mass production

| TABLE 2 - TRUTH TABLE | | | | | |
|-----------------------|---------------|--|---|----------------|--|
| INPUTS | | | OUTPUTS | | REMARK |
| SD | TXD | OPTICAL INPUT IRRADIANCE mW/m ² | RXD | TRANSMITTER | OPERATION |
| High > 1 ms | x | x | Weakly pulled (500 kΩ) to V _{CC1} | 0 | Shutdown |
| Low | High | x | Low active | I _e | Transmitting |
| | High > 100 μs | x | High inactive | 0 | Protection is active |
| | Low | < 4 | High inactive | 0 | Ignoring low signals below the IrDA defined threshold for noise immunity |
| | Low | > min. irradiance E _e < max. irradiance E _e | Low (active) | 0 | Response to an IrDA compliant optical input signal |
| | Low | > max. irradiance E _e | Undefined | 0 | Overload conditions can cause unexpected outputs |



ASSEMBLY INSTRUCTIONS

Reflow Soldering

- Reflow soldering must be done within 72 h while stored under a max. temperature of 30 °C, 60 % RH after opening the dry pack envelope
- Set the furnace temperatures for pre-heating and heating in accordance with the reflow temperature profile as shown in the diagram. Exercise extreme care to keep the maximum temperature below 260 °C. The temperature shown in the profile means the temperature at the device surface. Since there is a temperature difference between the component and the circuit board, it should be verified that the temperature of the device is accurately being measured
- Handling after reflow should be done only after the work surface has been cooled off

Manual Soldering

- Use a soldering iron of 25 W or less. Adjust the temperature of the soldering iron below 300 °C
- Finish soldering within 3 s
- Handle products only after the temperature has cooled off

VISHAY LEAD (Pb)-FREE REFLOW SOLDER PROFILE

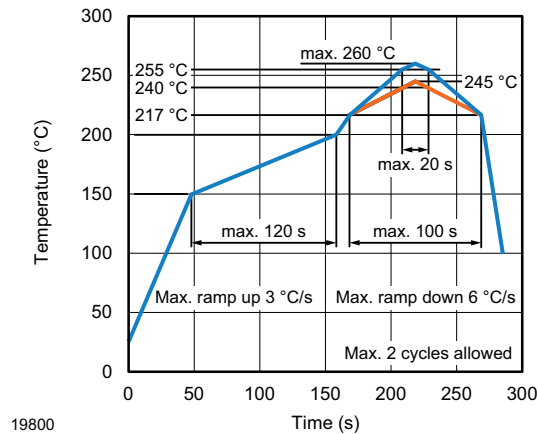



PACKAGE DIMENSIONS in millimeters

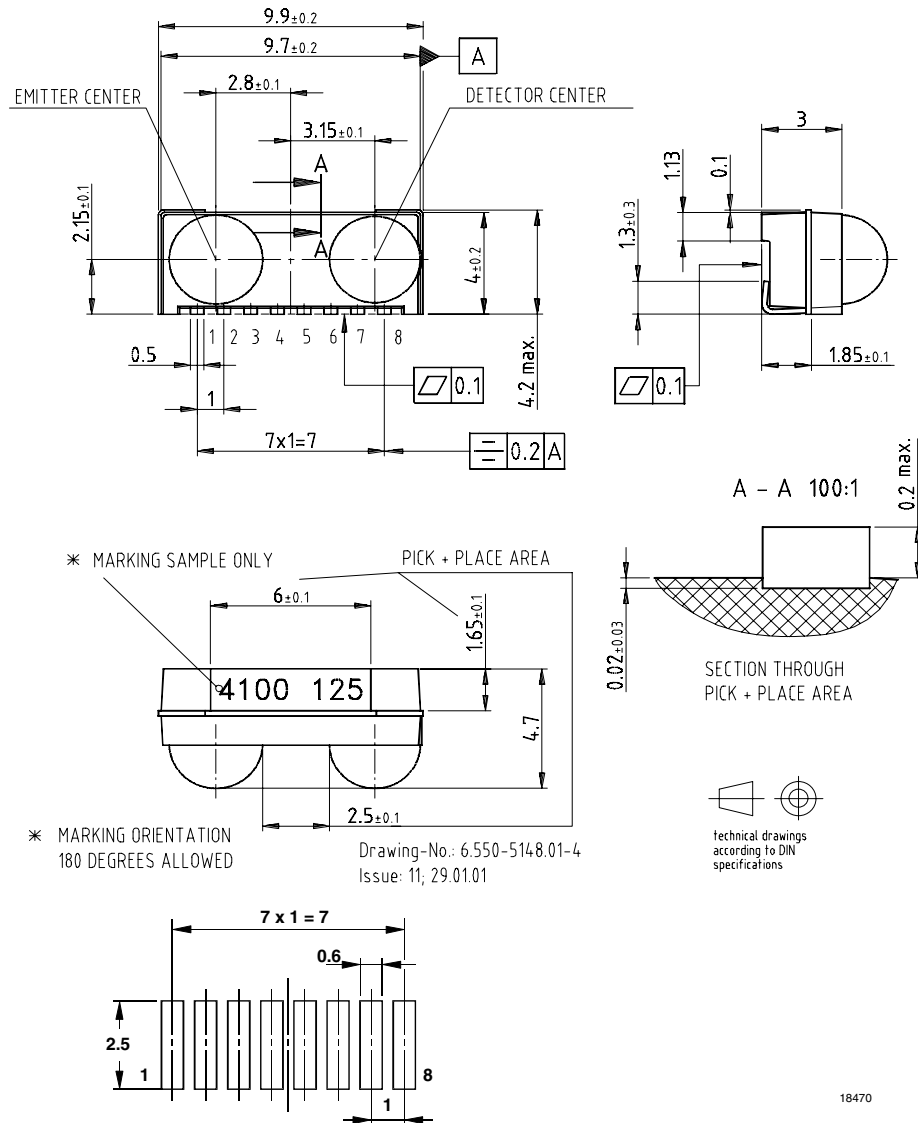

Fig. 3 - Package Drawing TFDU4101. Tolerance ± 0.2 mm if not otherwise mentioned

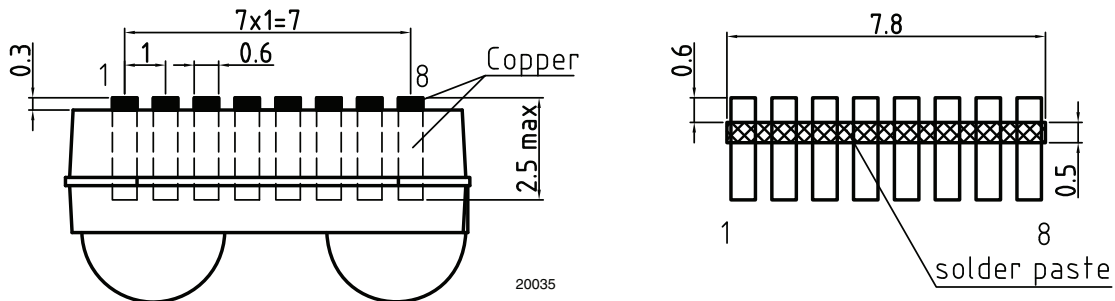

Fig. 4 - Recommended Footprint for Side View Applications and Solderpaste Mask

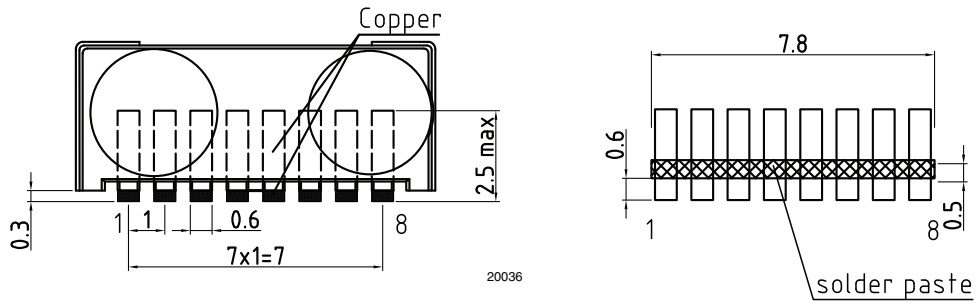
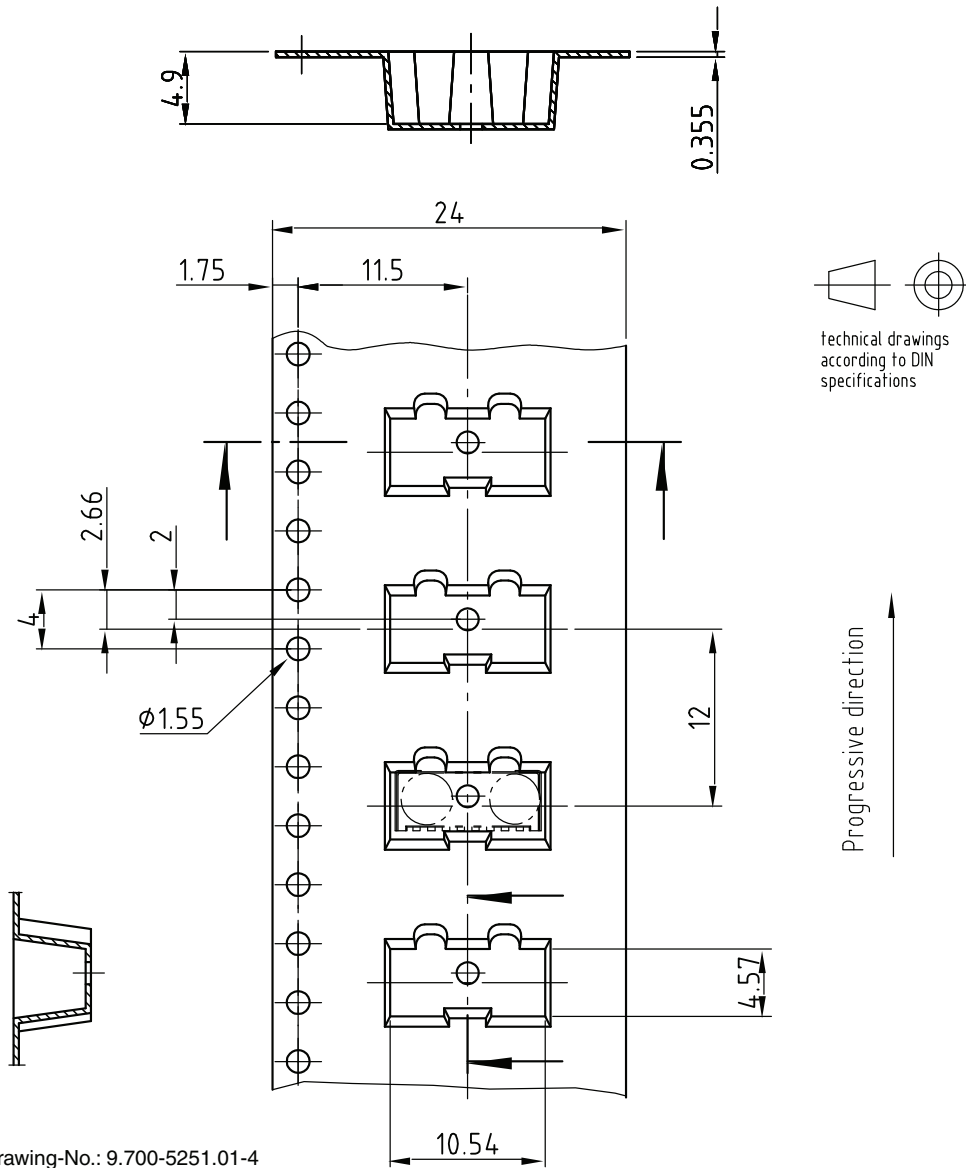

Fig. 5 - Recommended Footprint for Top View Applications and Solderpaste Mask

TAPE DIMENSIONS FOR TT3 in millimeters



technical drawings according to DIN specifications

Drawing-No.: 9.700-5251.01-4
Issue: 3; 02.09.05
19824

Fig. 6 - Tape Drawing, TFDU4101 for Top View Mounting, Tolerance ± 0.1 mm



TAPE DIMENSIONS FOR TR3 in millimeters

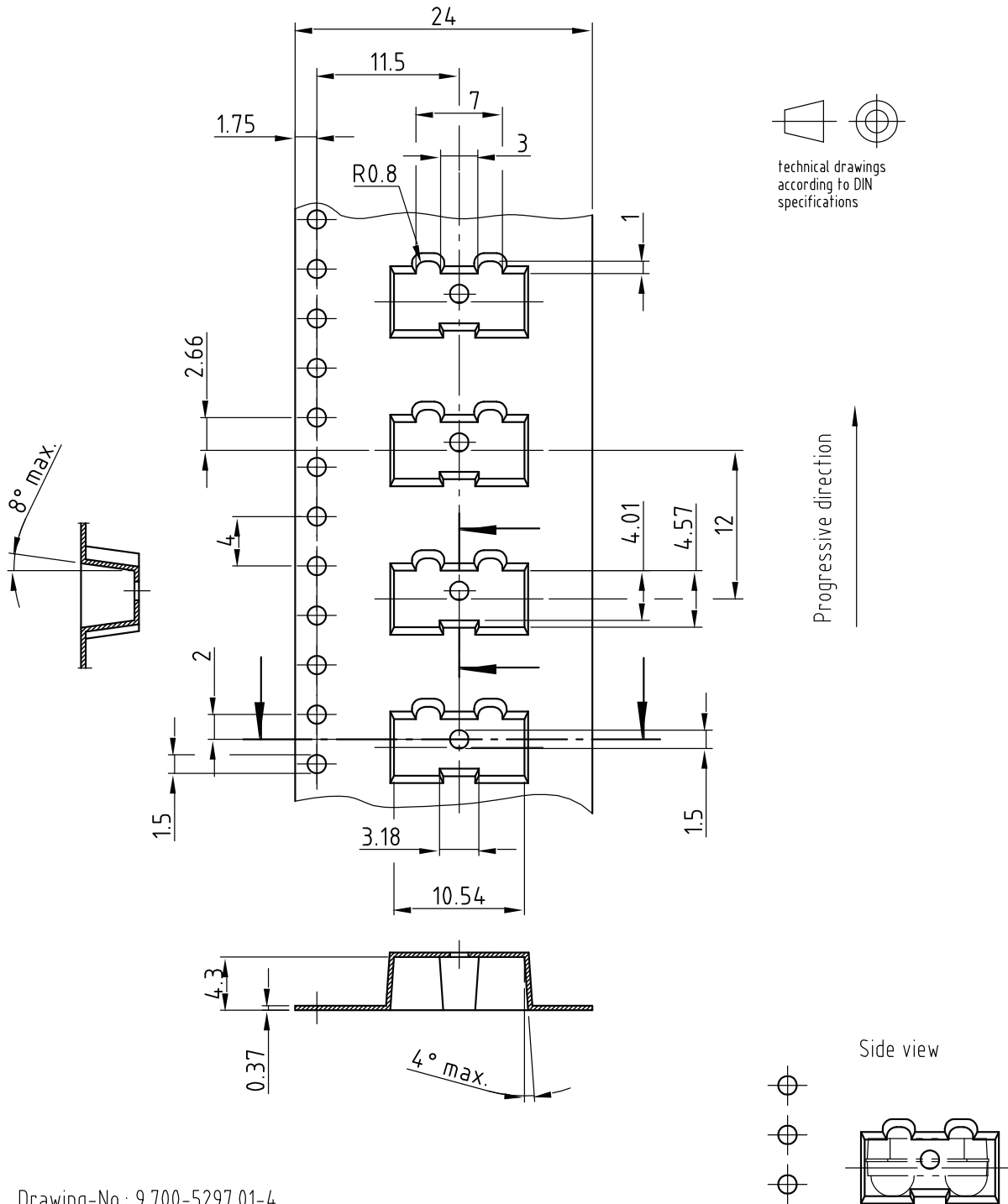

Drawing-No.: 9.700-5297.01-4

Issue: 3; 21.12.05

19875

Fig. 7 - Tape Drawing, TFDU4101 for Side View Mounting, Tolerance ± 0.1 mm



REEL DIMENSIONS in millimeters

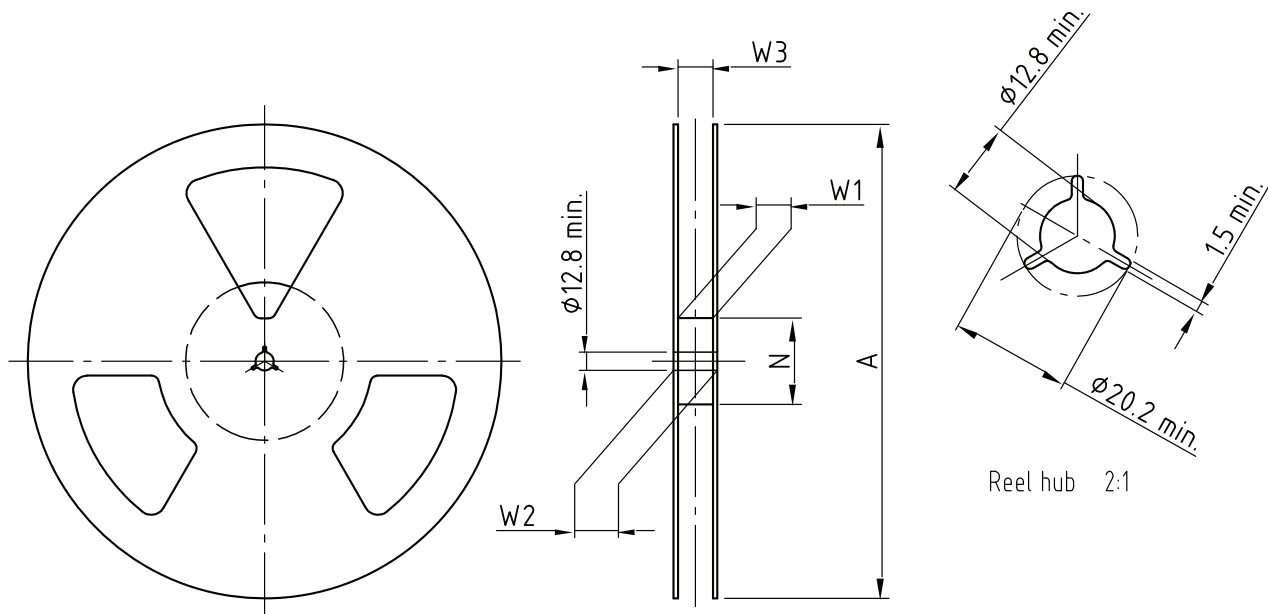

Drawing-No.: 9.800-5090.01-4
Issue: 1; 29.11.05
14017

Form of the leave open of the wheel is supplier specific.

Dimension acc. to IEC EN 60 286-3

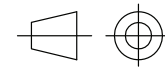

technical drawings according to DIN specifications

| TAPE WIDTH (mm) | A MAX. (mm) | N (mm) | W ₁ MIN. (mm) | W ₂ MAX. (mm) | W ₃ MIN. (mm) | W ₃ MAX. (mm) |
|-----------------|-------------|--------|--------------------------|--------------------------|--------------------------|--------------------------|
| 24 | 330 | 60 | 24.4 | 30.4 | 23.9 | 27.4 |

LEADER AND TRAILER DIMENSIONS in millimeters

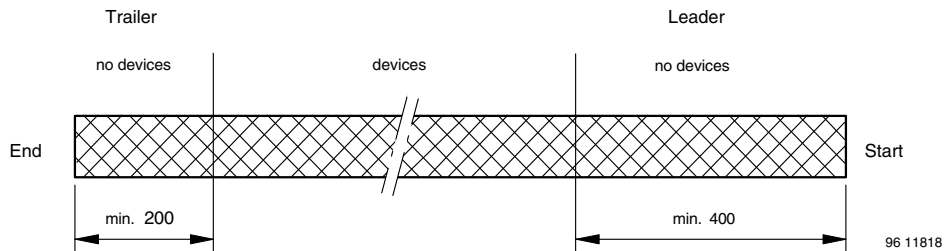

COVER TAPE PEEL STRENGTH

According to DIN EN 60286-3
0.1 N to 1.3 N
300 ± 10 mm/min.
165° to 180° peel angle

LABEL

Standard bar code labels for finished goods

The standard bar code labels are product labels and used for identification of goods. The finished goods are packed in final packing area. The standard packing units are labeled with standard bar code labels before transported as finished goods to warehouses. The labels are on each packing unit and contain Vishay Semiconductor GmbH specific data.



DRY PACKING

The reel is packed in an anti-humidity bag to protect the devices from absorbing moisture during transportation and storage.

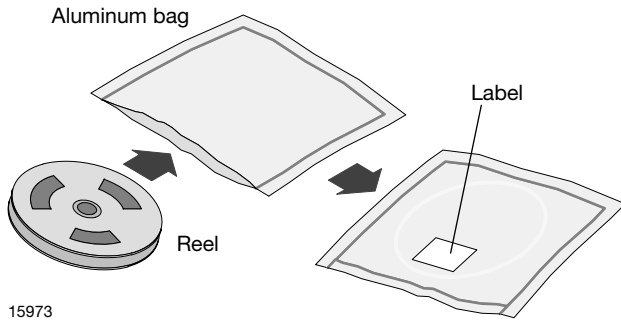

After more than 72 h under these conditions moisture content will be too high for reflow soldering.

In case of moisture absorption, the devices will recover to the former condition by drying under the following condition:
 192 h at 40 °C + 5 °C / - 0 °C and < 5 % RH (dry air / nitrogen)
 or
 96 h at 60 °C + 5 °C and < 5 % RH for all device containers or
 24 h at 125 °C + 5 °C not suitable for reel or tubes.

An EIA JEDEC® standard J-STD-020 level 4 label is included on all dry bags.

FINAL PACKING

The sealed reel is packed into a cardboard box.

RECOMMENDED METHOD OF STORAGE

Dry box storage is recommended as soon as the aluminum bag has been opened to prevent moisture absorption. The following conditions should be observed, if dry boxes are not available:

- Storage temperature 10 °C to 30 °C
- Storage humidity ≤ 60 % RH max.

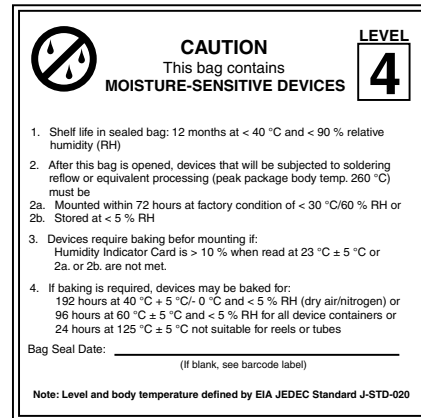

EIA JEDEC standard J-STD-020 level 4 label is included on all dry bags

OUTER PACKAGING

The sealed reel is packed into a pizza box.

| CARTON BOX DIMENSIONS in millimeters | | | | |
|--|-----------------------------|-----------|-------|--------|
| <p>Thickness</p> <p>Width</p> <p>Length</p> <p>22127</p> | | | | |
| ORDER CODE | BOXING | THICKNESS | WIDTH | LENGTH |
| TT3 / TR3 | Pizza box (taping in reels) | 50 | 340 | 340 |



| VISHAY SEMICONDUCTOR GmbH STANDARD BAR CODE PRODUCT LABEL (finished goods) | | |
|--|--------------|--------------|
| PLAIN WRITING | ABBREVIATION | LENGTH |
| Item-description | - | 18 |
| Item-number | INO | 8 |
| Selection-code | SEL | 3 |
| LOT-/serial-number | BATCH | 10 |
| Data-code | COD | 3 (YWW) |
| Plant-code | PTC | 2 |
| Quantity | QTY | 8 |
| Accepted by | ACC | - |
| Packed by | PCK | - |
| Mixed code indicator | MIXED CODE | - |
| Origin | xxxxxxx+ | Company logo |
| Long bar code top | Type | Length |
| Item-number | N | 8 |
| Plant-code | N | 2 |
| Sequence-number | X | 3 |
| Quantity | N | 8 |
| Total length | - | 21 |
| Short bar code bottom | Type | Length |
| Selection-code | X | 3 |
| Data-code | N | 3 |
| Batch-number | X | 10 |
| Filter | - | 1 |
| Total length | - | 17 |

The Vishay Semiconductors standard bar code labels are printed at final packing areas. The labels are on each packing unit and contain Vishay Semiconductors specific data.

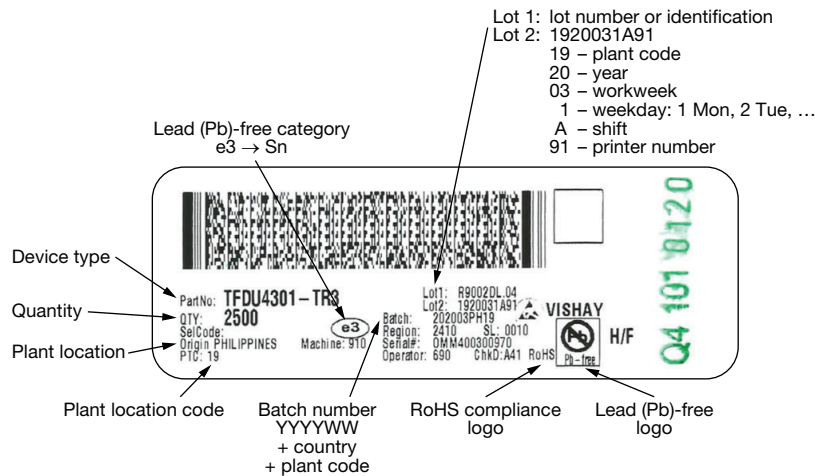

Fig. 8 - 2D Bar Code Label (according the bar code standard for 2D label PDF 417) for a Lead (Pb)-Free Device Made in Philippines, Detailed Description

ESD PRECAUTION

Proper storage and handling procedures should be followed to prevent ESD damage to the devices especially when they are removed from the antistatic shielding bag. Electrostatic sensitive devices warning labels are on the packaging.



Disclaimer

ALL PRODUCT, PRODUCT SPECIFICATIONS AND DATA ARE SUBJECT TO CHANGE WITHOUT NOTICE TO IMPROVE RELIABILITY, FUNCTION OR DESIGN OR OTHERWISE.

Vishay Intertechnology, Inc., its affiliates, agents, and employees, and all persons acting on its or their behalf (collectively, "Vishay"), disclaim any and all liability for any errors, inaccuracies or incompleteness contained in any datasheet or in any other disclosure relating to any product.

Vishay makes no warranty, representation or guarantee regarding the suitability of the products for any particular purpose or the continuing production of any product. To the maximum extent permitted by applicable law, Vishay disclaims (i) any and all liability arising out of the application or use of any product, (ii) any and all liability, including without limitation special, consequential or incidental damages, and (iii) any and all implied warranties, including warranties of fitness for particular purpose, non-infringement and merchantability.

Statements regarding the suitability of products for certain types of applications are based on Vishay's knowledge of typical requirements that are often placed on Vishay products in generic applications. Such statements are not binding statements about the suitability of products for a particular application. It is the customer's responsibility to validate that a particular product with the properties described in the product specification is suitable for use in a particular application. Parameters provided in datasheets and / or specifications may vary in different applications and performance may vary over time. All operating parameters, including typical parameters, must be validated for each customer application by the customer's technical experts. Product specifications do not expand or otherwise modify Vishay's terms and conditions of purchase, including but not limited to the warranty expressed therein.

Hyperlinks included in this datasheet may direct users to third-party websites. These links are provided as a convenience and for informational purposes only. Inclusion of these hyperlinks does not constitute an endorsement or an approval by Vishay of any of the products, services or opinions of the corporation, organization or individual associated with the third-party website. Vishay disclaims any and all liability and bears no responsibility for the accuracy, legality or content of the third-party website or for that of subsequent links.

Except as expressly indicated in writing, Vishay products are not designed for use in medical, life-saving, or life-sustaining applications or for any other application in which the failure of the Vishay product could result in personal injury or death. Customers using or selling Vishay products not expressly indicated for use in such applications do so at their own risk. Please contact authorized Vishay personnel to obtain written terms and conditions regarding products designed for such applications.

No license, express or implied, by estoppel or otherwise, to any intellectual property rights is granted by this document or by any conduct of Vishay. Product names and markings noted herein may be trademarks of their respective owners.