

MODEL: SJD1-3201-54 | **DESCRIPTION:** AUDIO JACK

FEATURES

- dual port jack - 3.5 mm and 2.5 mm
- placement pins for secure PCB mounting
- 2 switch design for 3.5 mm port; 1 switch for 2.5 mm port



SPECIFICATIONS

parameter	conditions/description	min	typ	max	units
rated input voltage			12		Vdc
rated input current				1	A
contact resistance				30	mΩ
insulation resistance	at 500 Vdc	100			MΩ
voltage withstand				500	Vac
insertion/withdrawal force		0.3		3	kg
operating temperature		-25		85	°C
storage temperature		-40		85	°C
life			5,000		cycles
flammability rating	see material table				
RoHS	yes				

SOLDERABILITY

parameter	conditions/description	min	typ	max	units
wave soldering	for max 5 seconds	255	260	265	°C

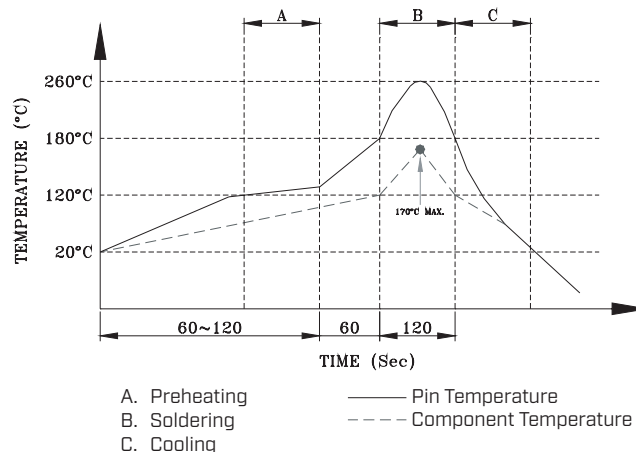

MECHANICAL DRAWING

units: mm
 tolerance:
 X.X ±0.2 mm
 X.XX ±0.15 mm
 X.XXX ±0.10 mm
 PCB: ±0.05 mm

DESCRIPTION	MATERIAL	PLATING/COLOR
terminal 1	copper alloy	tin
terminal 2	stainless steel t=0.20	tin
terminal 3	stainless steel t=0.20	tin
terminal 10	brass t=0.40	tin
terminal 11	brass t=0.40	tin
terminal 20	brass t=0.40	tin
terminal 21	phosphor bronze t=0.30	tin
terminal 22	stainless steel t=0.20	tin
terminal 23	phosphor bronze t=0.25	tin
bushing	copper alloy	nickel
housing	PA66+GF15% (UL94HB)	black

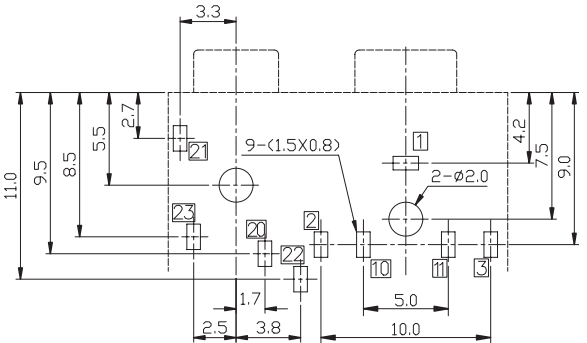
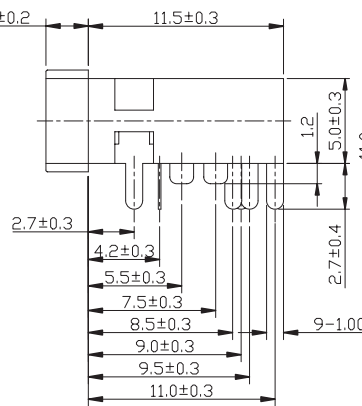
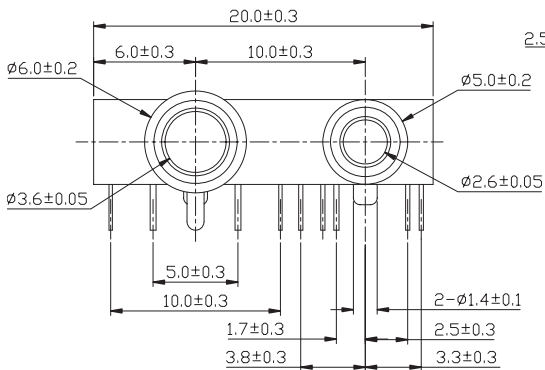

Recommended PCB Layout
 Top View

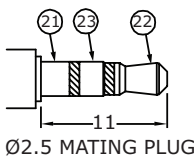
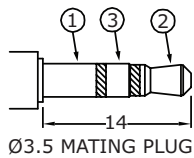

Model No.	SJD1-3201-54	
Schematic	PIN	
	1	sleeve
	2	tip
	3	ring
	10	tip switch
	11	ring switch
	2	
	20	tip switch
	21	sleeve
	22	tip
	23	ring
	21	
	22	

REVISION HISTORY

rev.	description	date
1.0	initial release	08/07/2007
1.01	updated pin numbering	01/15/2008
1.02	changed part mold tooling	04/07/2017
1.03	brand update	10/14/2019
1.04	product reengineered for improved manufacturability and production yield, see PCN for details	06/14/2023

The revision history provided is for informational purposes only and is believed to be accurate.



CUI Devices offers a one (1) year limited warranty. Complete warranty information is listed on our website.

CUI Devices reserves the right to make changes to the product at any time without notice. Information provided by CUI Devices is believed to be accurate and reliable. However, no responsibility is assumed by CUI Devices for its use, nor for any infringements of patents or other rights of third parties which may result from its use.

CUI Devices products are not authorized or warranted for use as critical components in equipment that requires an extremely high level of reliability. A critical component is any component of a life support device or system whose failure to perform can be reasonably expected to cause the failure of the life support device or system, or to affect its safety or effectiveness.

cuiddevices.com