

REVISIONS					
ZONE	LTR	ECN	DESCRIPTION	DATE	APPROVED
	A	28680	RELEASE FOR PRODUCTION	KC 4-16-80	HA
	B	34350	GENERAL UPDATE, SEE ECN	10/10/92	HA
	C	34422	GENERAL UPDATE, SEE ECN	11/20/92	HA

**CAUTION**  
 UNINSULATED WIRES USED IN THIS ASSEMBLY.  
 MUST PASS 600 VOLT "HI-POT" AFTER POTTING

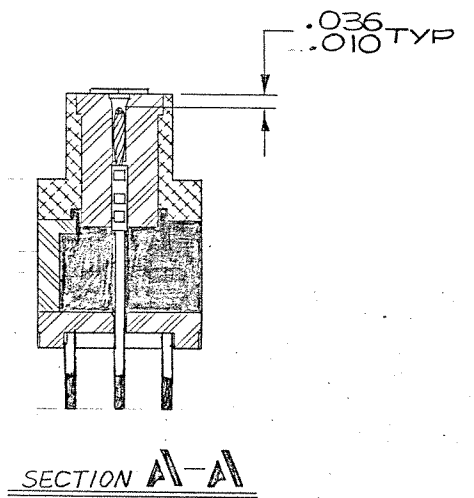
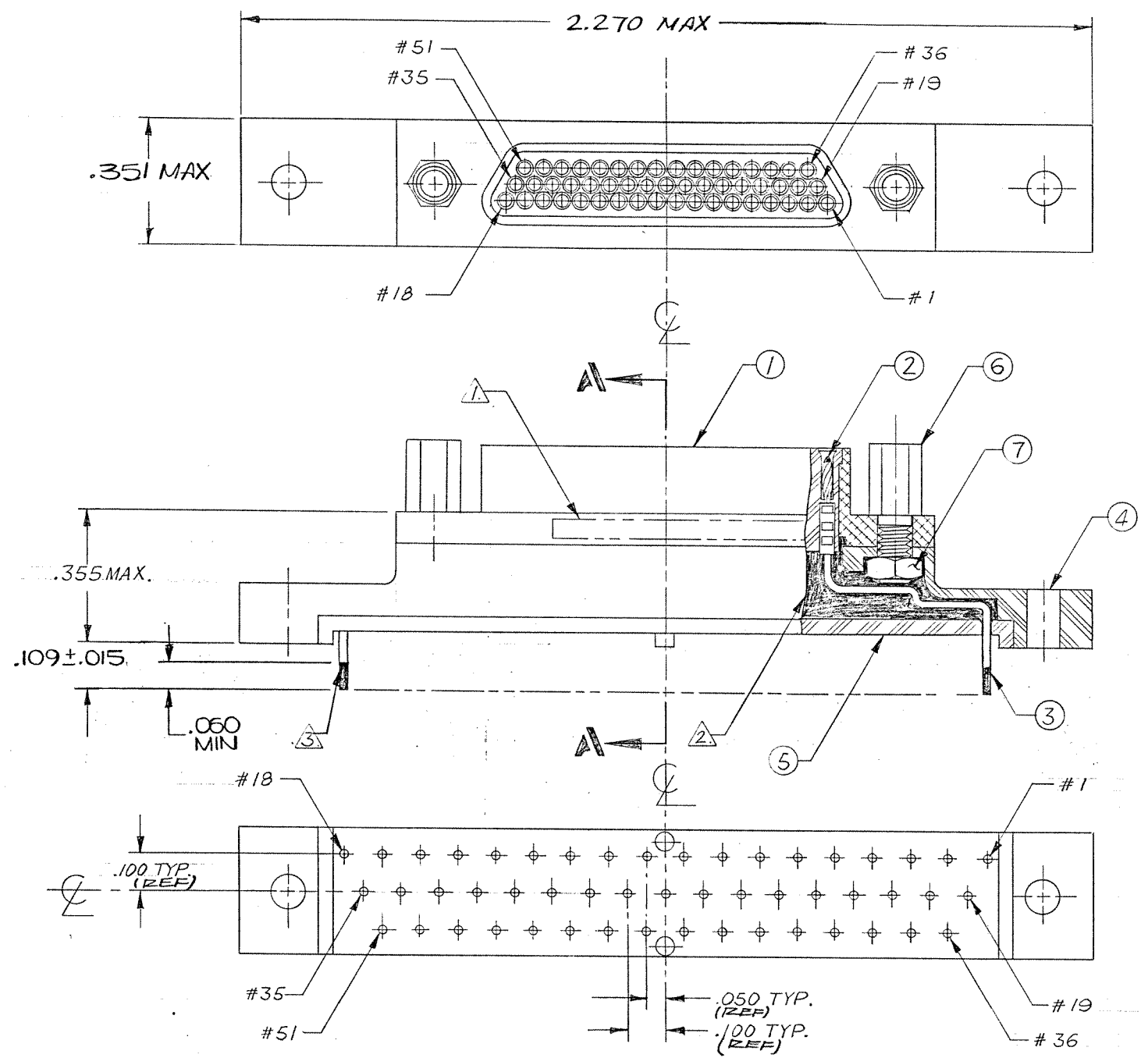

- NOTES : UNLESS OTHERWISE SPECIFIED.
- 1. MARK "MALCO" OR MALCO LOGO, MALCO PART NO., CODE IDENT NO., DATE CODE W/ .047 MIN HIGH CHARACTERS IN APPROX. LOCATION SHOWN.
  - 2. ASSEMBLE ALL ITEMS (ITEM #1 THRU #7), THEN FILL WITH EPOXY AS SHOWN. USE HYSOL # 4215 & # 3561.
  - 3. TERMINAL WIRES ARE TO BE SOLDER COATED SOLDER TO BE QR-S-571, TYPE Sn60 or Sn63 FLUX PER MIL-F-14256, TYPE A..
  - 4. CRIMP LEADS INTO CONTACTS PER MEP 302-05.
  - 5. DELETED
  - 6. DELETED

Tyco Dwg 2-1532142-1  
 Micro P/N 094-5704-7000

QTY REQD	CODE IDENT	PART OR IDENTIFYING NO.	NOMENCLATURE OR DESCRIPTION	CONTRACT NO.
PARTS LIST				
UNLESS OTHERWISE SPECIFIED DIMENSIONS ARE IN INCHES		CONTRACT NO.		
TOLERANCES ARE:		APPROVALS		
FRACTIONS	DECIMALS	ANGLES	DATE	<b>MALCO</b> A MICRODOT COMPANY, INC. 306 PASADENA AVE., SO. PASADENA, CALIF. 91030 PROD. CODE 845 CODE M
±	.XX ±	±		
	.XXX ±	.005 ±		
MATERIAL		FINISH		
NEXT ASSY		USED ON		
APPLICATION		DO NOT SCALE DRAWING		
SIZE		CODE IDENT NO.	DRAWING NO.	
D		98278	094-5704-7000	
SCALE		SHEET / OF /		