

THIS DRAWING IS UNPUBLISHED. RELEASED FOR PUBLICATION 20
 © COPYRIGHT 20 BY TYCO ELECTRONICS CORPORATION. ALL RIGHTS RESERVED.

LOC	DIST	REVISIONS			
P	LTR	DESCRIPTION	DATE	DWN	APVD
V	00	A	Initial release	16APR2009	RV HB
		B	ECR-13-003924	06MAR2013	WDV HB

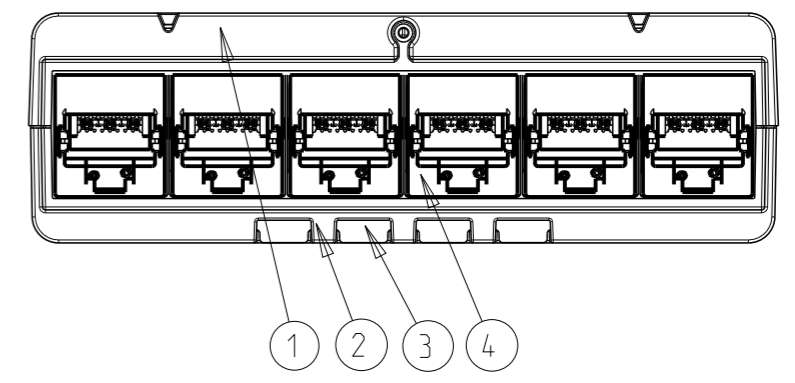
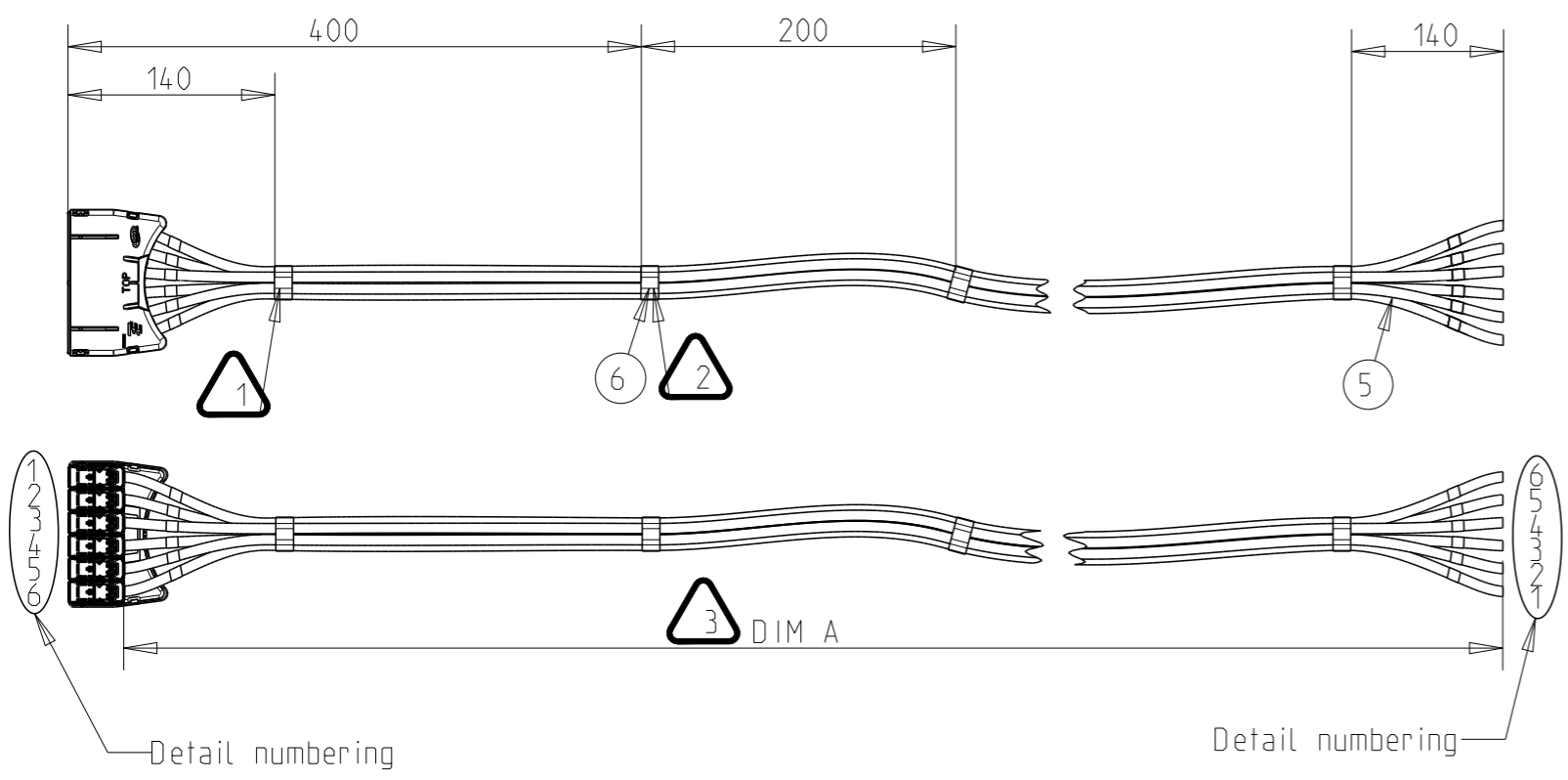

- 1 White tape (approved by Tyco Electronics), second at 260, then every 200mm
 - 2 First white tape, then product label over the second and last but one tape according to the product ID label
- X-...-Y see catalogue
 Z.Z = length in m
 YY = year (2digits)
 WW = week (2digits)
 MI= SAP vendor nbr
 Rev.X= revision nbr
 XXX= unique serial nbr per assy defined by vendor

TE PN X-1671221-Y
 S-Link STP Class EA Z.Z m
 YYWW-MI-Rev.X
 Serial nbr. XXX

- B PACKAGING according to spec. 107-93008
- 3 Overall length of cable assemblies is min -0, max +2%
 Available lengths: see catalogue

4. 100% Factory tested

QUANTITY	DESCRIPTION	ITEM
1	QC-document	8
1	Installation Instruction	7
1	Product Label	6
Depending on length	Cable Cat 7 S/FTP LSFRZH	5
6	AMP-TWIST- 6S JACK	4
1	AMP Sigma-Link Connector Plate	3
1	AMP Sigma-Link Casette Bottom	2
1	AMP Sigma-Link Casette Top	1

<small>THIS DRAWING IS A CONTROLLED DOCUMENT FOR TYCO ELECTRONICS CORPORATION IT IS SUBJECT TO CHANGE AND THE CONTROLLING ENGINEERING ORGANIZATION SHOULD BE CONTACTED FOR THE LATEST REVISION.</small>		DWN R.VANDOREN 16APR2009 CHK H.BLEUS 16APR2009 APVD D.THUIS 16APR2009		Tyco Electronics Kessel-Lo, Belgium	
DIMENSIONS: mm 		TOLERANCES UNLESS OTHERWISE SPECIFIED: 0 PLC ±SEE TABLE 1 PLC ±SEE TABLE 2 PLC ±SEE TABLE 3 PLC ±SEE TABLE 4 PLC ±SEE TABLE ANGLES ±SEE TABLE		NAME AMP SIGMA-Link Classic Cable assembly STP Class EA / C to E	
MATERIAL -		FINISH -		PRODUCT SPEC - APPLICATION SPEC - WEIGHT -	
CUSTOMER DRAWING		SIZE A3 CAGE CODE 00779 DRAWING NO ©=1671221		RESTRICTED TO -	
SCALE n.a.		SHEET 1 OF 1		REV B	