

## OMNIMATE Signal - series TOP1.5GS TOP1.5GS2/90 7 2STI OR

**Weidmüller Interface GmbH & Co. KG**  
Klingenbergstraße 16  
D-32758 Detmold  
Germany  
Fon: +49 5231 14-0  
Fax: +49 5231 14-292083  
www.weidmueller.com

### Product image

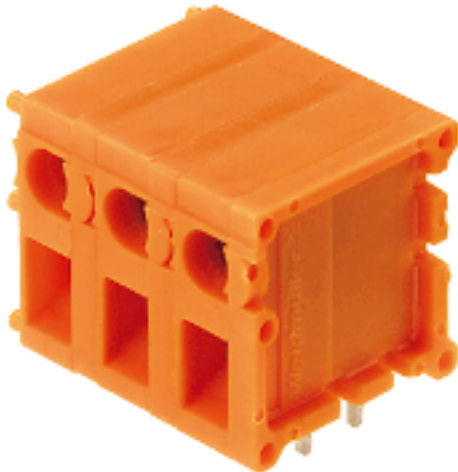

Similar to illustration

Conductor entry and screw connection in the same direction on this PCB terminal with 7.62 mm pitch for conductor cross-sections up to 2.5 mm<sup>2</sup>. Conductor outlet direction 90° and 180°.

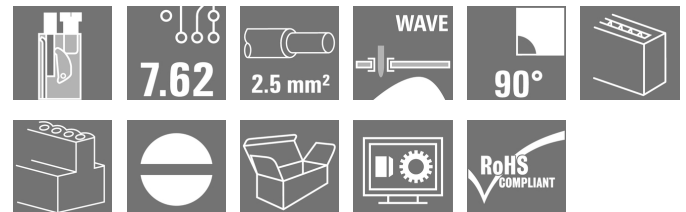

### General ordering data

Type	TOP1.5GS2/90 7 2STI OR
Order No.	<a href="#">0393360000</a>
Version	PCB terminal, 7.62 mm, No. of poles: 2, 90°, Solder pin length (l): 3.5 mm, tinned, Orange, TOP connection, Clamping range, max.: 2.5 mm <sup>2</sup> , Box
GTIN (EAN)	4008190174941
Qty.	100 pc(s).
Product data	IEC: 1000 V / 24 A / 0.5 - 2.5 mm <sup>2</sup> UL: 300 V / 10 A / AWG 26 - AWG 14
Packaging	Box

**OMNIMATE Signal - series TOP1.5GS  
TOP1.5GS2/90 7 2STI OR**

**Weidmüller Interface GmbH & Co. KG**  
 Klingenbergstraße 16  
 D-32758 Detmold  
 Germany  
 Fon: +49 5231 14-0  
 Fax: +49 5231 14-292083  
 www.weidmueller.com

**Technical data****Dimensions and weights**

Width	17.04 mm	Width (inches)	0.671 inch
Height	22 mm	Height (inches)	0.866 inch
Height of lowest version	18.5 mm	Depth	19.5 mm
Depth (inches)	0.768 inch	Net weight	7.66 g

**System parameters**

Product family	OMNIMATE Signal - series TOP1.5GS	Wire connection method	TOP connection
Mounting onto the PCB	THT solder connection	Conductor outlet direction	90°
Pitch in mm (P)	7.62 mm	Pitch in inches (P)	0.3 inch
No. of poles	2	Fitted by customer	No
Solder pin length (l)	3.5 mm	Solder pin dimensions	0.8 x 1.0 mm
Solder eyelet hole diameter (D)	1.3 mm	Solder eyelet hole diameter tolerance (D)	+ 0,1 mm
Number of solder pins per pole	2	Screwdriver blade	0.6 x 3.5
Screwdriver blade standard	DIN 5264	Tightening torque, min.	0.4 Nm
Tightening torque, max.	0.5 Nm	Clamping screw	M 2.5
Stripping length	10 mm	L1 in mm	7.62 mm
L1 in inches	0.3 inch	Touch-safe protection acc. to DIN VDE 0470	IP 20
Touch-safe protection acc. to DIN VDE 57 106	Safe from finger touch	Volume resistance	1.20 mΩ

**Material data**

Insulating material	PA	Colour	Orange
Colour chart (similar)	RAL 2000	Insulating material group	I
CTI	≥ 600	Insulation resistance	≥ 10 <sup>8</sup> Ω
UL 94 flammability rating	V-2	Contact material	CuZn
Contact surface	tinned	Layer structure of solder connection	1.5-3 μm Ni / 4-6 μm Sn
Storage temperature, min.	-25 °C	Storage temperature, max.	55 °C
Max. relative humidity during storage	80 %	Operating temperature, min.	-50 °C
Operating temperature, max.	100 °C	Temperature range, installation, min.	-25 °C
Temperature range, installation, max.	100 °C		

**Conductors suitable for connection**

Clamping range, min.	0.13 mm <sup>2</sup>	Clamping range, max.	2.5 mm <sup>2</sup>
Wire connection cross section AWG, min.	AWG 26	Wire connection cross section AWG, max.	AWG 14
Solid, min. H05(07) V-U	0.5 mm <sup>2</sup>	Solid, max. H05(07) V-U	2.5 mm <sup>2</sup>
Flexible, min. H05(07) V-K	0.5 mm <sup>2</sup>	Flexible, max. H05(07) V-K	2.5 mm <sup>2</sup>
w. plastic collar ferrule, DIN 46228 pt 4, min.	0.5 mm <sup>2</sup>	w. plastic collar ferrule, DIN 46228 pt 4, max.	2.5 mm <sup>2</sup>
w. wire end ferrule, DIN 46228 pt 1, min.	0.5 mm <sup>2</sup>	w. wire end ferrule, DIN 46228 pt 1, max.	2.5 mm <sup>2</sup>
Plug gauge in accordance with EN 60999 a x b; ø	2.4 mm x 1.5 mm		

**OMNIMATE Signal - series TOP1.5GS  
TOP1.5GS2/90 7 2STI OR**

**Weidmüller Interface GmbH & Co. KG**  
Klingenbergstraße 16  
D-32758 Detmold  
Germany  
Fon: +49 5231 14-0  
Fax: +49 5231 14-292083  
www.weidmueller.com

**Technical data**
**Rated data acc. to IEC**

tested acc. to standard		IEC 60664-1, IEC 61984	
Rated current, max. no. of poles (Tu=20°C)	19 A	Rated current, min. no. of poles (Tu=20°C)	24 A
Rated current, max. no. of poles (Tu=40°C)	16 A	Rated current, min. no. of poles (Tu=40°C)	21 A
Rated voltage for surge voltage class / pollution degree III/2	630 V	Rated voltage for surge voltage class / pollution degree II/2	1,000 V
Rated impulse voltage for surge voltage class/ pollution degree II/2	4 kV	Rated voltage for surge voltage class / pollution degree III/3	400 V
Rated impulse voltage for surge voltage class/ contamination degree III/3	4 kV	Rated impulse voltage for surge voltage class/ pollution degree III/2	4 kV
		Short-time withstand current resistance	3 x 1s with 120 A

**Rated data acc. to CSA**

Institute (CSA)		Certificate No. (CSA)	154685-1501716
Rated voltage (Use group B / CSA)	300 V	Rated voltage (Use group D / CSA)	300 V
Rated current (Use group B / CSA)	10 A	Rated current (Use group D / CSA)	10 A
Wire cross-section, AWG, min.	AWG 26	Wire cross-section, AWG, max.	AWG 14
Reference to approval values	Specifications are maximum values, details - see approval certificate.		

**Rated data acc. to UL 1059**

Rated voltage (Use group B / UL 1059)	300 V	Rated voltage (Use group D / UL 1059)	300 V
Rated current (Use group B / UL 1059)	10 A	Rated current (Use group D / UL 1059)	10 A
Wire cross-section, AWG, min.	AWG 26	Wire cross-section, AWG, max.	AWG 14

**Packaging**

Packaging	Box	VPE length	48 mm
VPE width	134 mm	VPE height	200 mm

**Classifications**

ETIM 3.0	EC001284	ETIM 4.0	EC002643
ETIM 5.0	EC002643	ETIM 6.0	EC002643
UNSPSC	30-21-18-01	eClass 6.2	27-26-11-01
eClass 7.1	27-44-04-01	eClass 8.1	27-44-04-01
eClass 9.0	27-44-04-01	eClass 9.1	27-44-04-01

**Data sheet**

**OMNIMATE Signal - series TOP1.5GS  
TOP1.5GS2/90 7 2STI OR**

**Weidmüller Interface GmbH & Co. KG**  
Klingenbergstraße 16  
D-32758 Detmold  
Germany  
Fon: +49 5231 14-0  
Fax: +49 5231 14-292083  
www.weidmueller.com

**Technical data**

**Notes**

- |       |   |
|-------|---|
| Notes | <ul style="list-style-type: none"> <li>• Additional colours on request</li> <br/> <li>• Rated current related to rated cross-section &amp; min. No. of poles.</li> <br/> <li>• Wire end ferrule without plastic collar to DIN 46228/1</li> <br/> <li>• Wire end ferrule with plastic collar to DIN 46228/4</li> <br/> <li>• Crimp form A for wire end ferrules with PZ 6/5 crimping tool are recommended for the largest cable sizes.</li> <br/> <li>• P on drawing = pitch</li> <br/> <li>• Rated data refer only to the component itself. Clearance and creepage distances to other components are to be designed in accordance with the relevant application standards.</li> </ul> |
|-------|---|

IPC conformity	Conformity: The products are developed, manufactured and delivered according international recognized standards and norms and comply with the assured properties in the data sheet resp. fulfill decorative properties in accordance with IPC-A-610 "Class 2". Further claims on the products can be evaluated on request.
----------------	--

**Approvals**

Approvals



ROHS	Conform
------	---------

**Downloads**

- |                    |  |
|--------------------|--|
| Brochure/Catalogue | <a href="#">FL DRIVES EN</a><br><a href="#">FL ANALO.SIGN.CONV. EN</a><br><a href="#">MB DEVICE MANUF. EN</a><br><a href="#">FL DRIVES DE</a><br><a href="#">CAT 2 PORTFOLIOGUIDE EN</a><br><a href="#">FL BUILDING SAFETY EN</a><br><a href="#">FL APPL LED LIGHTING EN</a><br><a href="#">FLIndustr.CONTROLS EN</a><br><a href="#">FL MACHINE SAFETY EN</a><br><a href="#">FL HEATING ELECTR EN</a><br><a href="#">FL APPL INVERTER EN</a><br><a href="#">FL BASE STATION EN</a><br><a href="#">FL ELEVATOR EN</a><br><a href="#">FL POWER SUPPLY EN</a><br><a href="#">FL 72H SAMPLE SER EN</a><br><a href="#">PO OMNIMATE EN</a> |
| Engineering Data   | <a href="#">EPLAN.WSCAD</a>  |

**OMNIMATE Signal - series TOP1.5GS  
TOP1.5GS2/90 7 2STI OR**

**Weidmüller Interface GmbH & Co. KG**  
 Klingenbergstraße 16  
 D-32758 Detmold  
 Germany  
 Fon: +49 5231 14-0  
 Fax: +49 5231 14-292083  
 www.weidmueller.com

**Drawings**

**Dimensional drawing**

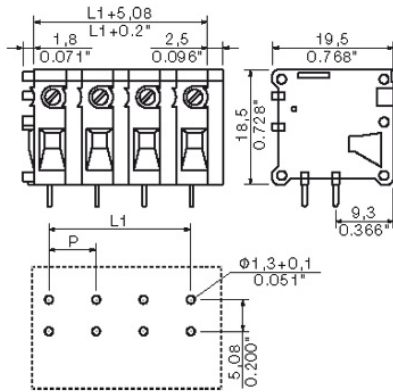

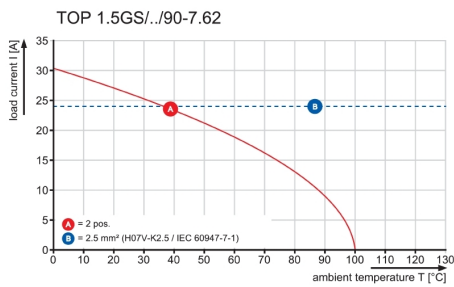

**Graph**



MASSE OHNE TOLERANZ SIND KEINE PRUEFMASSE  
 DIMS. WITHOUT TOLERANCE ARE NOT CONTROL DIMS.

DIE DEUTSCHE VERSION IST VERBINDLICH  
 THE GERMAN VERSION IS BINDING

**Technical Data**

<b>Rev.</b>		
<b>Material data</b>		
Insulation material type		PA 66
Insulation material colours		S 33230
Insulation material flammability class	UL94	V-2
Insulation resistance	MOhm	10 <sup>3</sup>
Contact base material		CuZn
Contact plating (mating end)		Tin-plated
Contact plating (solder end)		n/a
<b>System characteristic values</b> together with counterpart		
Pitch P	mm/inch	7.62 / 0.3
Number of rows		1
Dielectric strength (r.m.s withstand voltage)	kV	2.5
Conductor connection methode		TOP connection
Plug in force (max.)	N/pole	n/a
Pull out force (max.)	N/pole	n/a
Through resistance (typical)	mOhm	0.9
Operating temperature range	°C	-20....+100
Degree of protection acc. to VDE 0106 (plugged/unplugged)		finger safe
Degree of protection acc. to DIN EN 60529 (plugged/unplugged)		IP20
Solder pin length L	mm/inch	3.5
PCB hole diameter D (wave soldering)	mm/inch	1.3
PCB hole diameter D (reflow soldering)	mm/inch	n/a
Resistance to soldering heat acc. to DIN IEC 60512-6	°C/sec	260/10
Resistance to soldering heat acc. to EN 61760-1	°C/sec	n/a
Solderability classification acc. to EN 61760-1		n/a
Solder connection type		wave soldering
Solder pin diameter d (max.)	mm/inch	1.28/0.05
<b>Application notes</b>		
Coding possibility	yes/no	no
Joinable without loss of pitch	yes/no	no
Manual assembly of modules	yes/no	yes
Max. number of poles	n	12
<b>IEC 664-1 / VDE0110 (4.97) rated data</b>		
Rated cross section acc. to EN 60999	mm <sup>2</sup>	1.5
Rated current @ 20°C ambient (together with)	A	16
Rated current @ 40°C ambient (together with)	A	xxx
<b>Overvoltage category / Pollution degree</b>		
Rated voltage	V	500 630 1000
Rated impulse voltage	kV	6.0 6.0 6.0
<b>UL 1059 rated data</b>  File No.: E60693		
Rated voltage	V	300
Rated current	A	10
Clamping range	mm <sup>2</sup> / AWG	0.5...1.5/26..14
<b>CSA C22.2 rated data</b>  File No.: LR12400		
Rated voltage	V	300
Rated current	A	10
Clamping range	mm <sup>2</sup> / AWG	0.5.....1.5/26....14
<b>Packaging</b>		
		carton
<b>Downloads</b>		
		www.weidmueller.de

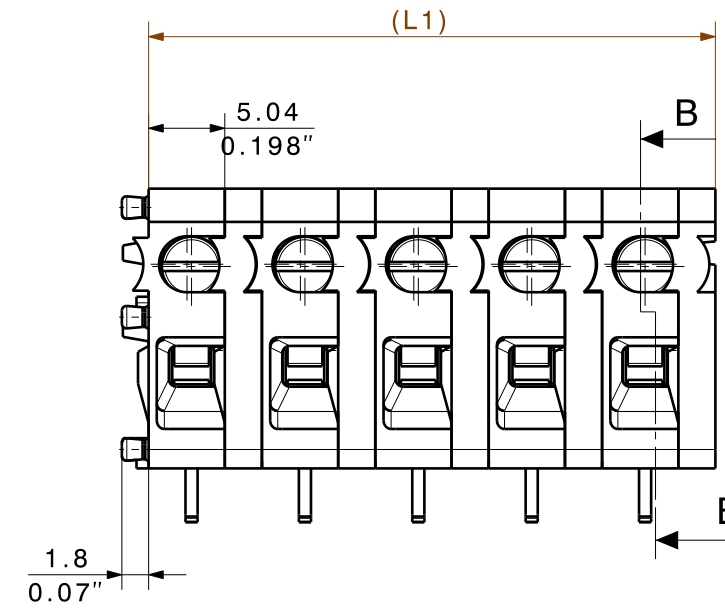
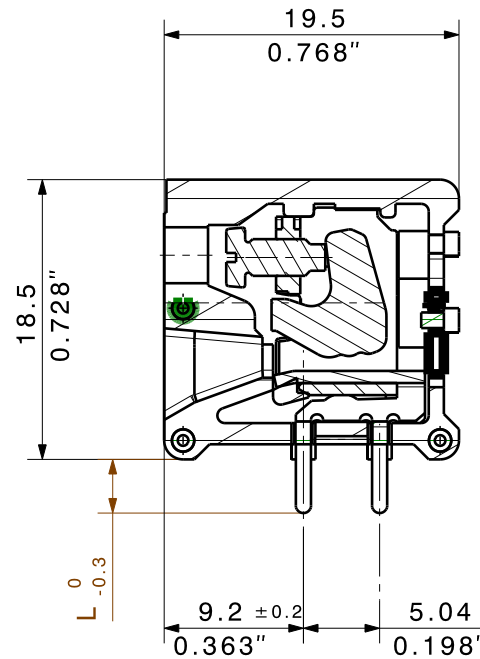

**Drilling Diagram**

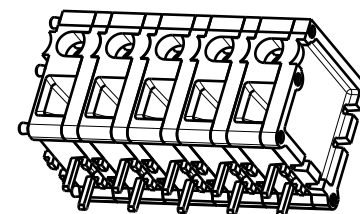
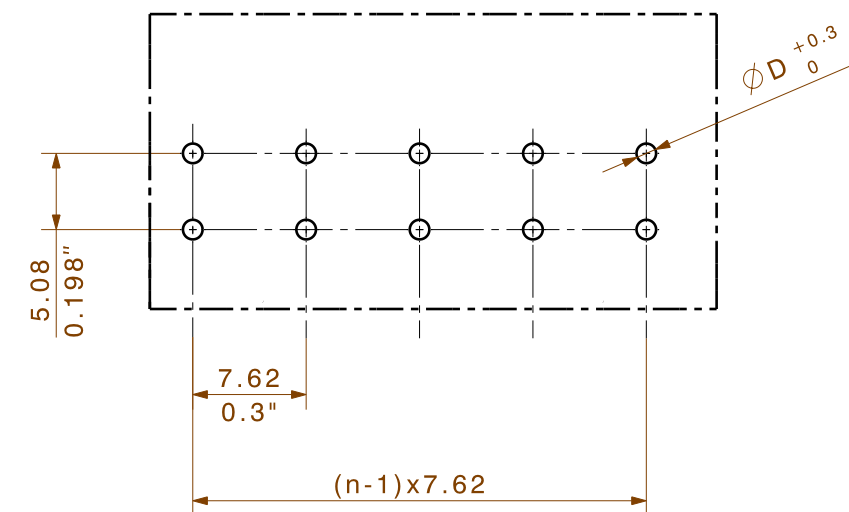

12	91,44	3,600
11	83,82	3,300
10	76,20	3,000
9	68,58	2,700
8	60,96	2,400
7	53,34	2,100
6	45,72	1,800
5	38,10	1,500
4	30,48	1,200
3	22,86	0,900
2	15,24	0,600
1	7,62	0,300
n	L1 [mm]	L1 [Inch]

02 Zeichnung komplett überarbeitet

- Without locking latches
- Sum of ambient temperature and temperature rise
- Recommendation for manual assembly
- Recommendation for automatic assembly
- Recommendation for wave soldering
- Recommendation for reflow soldering
- Referred to rated cross section and minimum pole number

n.a. = not applicable

Subject to technical changes

For the mounting of PCBs, it should be noted that the rated data stated here relates only to the PCB components alone. The necessary creepage and clearance paths must be observed in connection with the respective applicant in accordance to IEC 664 / VDE 0110. The current-carrying capacity and pitch tolerance is to be determined according to DIN IEC 326 part 3 very fine.

Weidmüller PCB components are tested to the DIN EN 61984 standard, and are valid for its field of application. Provided that the components are used to the intended purpose, all requirements with respect to the occurring of electrical, mechanical, thermic and corrosive stress will be satisfied.

<b>METRIC TOLERANCES:</b> X. = ±0.3 X.X = ±0.1 X.XX = ±0.05		35928/5 05.09.06 KRUG_M 01	CAT.NO.: <b>C 33230 02</b>
<b>METRIC/INCH DIMENSIONS</b>		<b>MODIFICATION</b>	<b>Weidmüller</b>
DRAWN: 06.04.2004 HEINEL_M	DATE: 06.04.2004	NAME: HEINEL_M	DRAWING NO. C 33230 02
SCALE: 2:1	RESPONSIBLE: KRUG_M	CHECKED: 05.09.2006 HECKERT_M	SHEET 3 OF 4 SHEETS
SUPERSEDES:	APPROVED:	GÜNTHER_W	PRODUCT FILE:
SUPERSEDED BY:	<b>TOP 1.5 GS /90 2STI</b>		

WEITERGABE SOWIE VERVIELFÄLTIGUNG DIESES DOKUMENTS, VERWERTUNG UND MITTEILUNG SEINES INHALTS SIND VERBOTEN, SOWEIT NICHT AUSDRUECKLICH GESTATET.  
 ZUWIDERHANDLUNGEN VERPFLICHTEN ZU SCHADENSERSATZ. ALLE RECHTE FUER DEN FALL DER PATENT-, GEBRAUCHSMUSTER- ODER GESCHMACKSMUSTERINTEGRATION VORBEHALTEN.  
 THE REPRODUCTION, DISTRIBUTION AND UTILIZATION OF THIS DOCUMENT AS WELL AS THE COMMUNICATION OF ITS CONTENTS TO OTHERS WITHOUT EXPLICIT AUTHORIZATION IS PROHIBITED.  
 OFFENDERS WILL BE HELD LIABLE FOR THE PAYMENT OF DAMAGES. ALL RIGHTS RESERVED IN THE EVENT OF THE GRANT OF A PATENT, UTILITY MODEL OR DESIGN.

## Recommended wave soldering profiles

**Weidmüller Interface GmbH & Co. KG**  
 Klingenbergstraße 16  
 D-32758 Detmold  
 Germany  
 Fon: +49 5231 14-0  
 Fax: +49 5231 14-292083  
 www.weidmueller.com

### Single Wave:



### Double Wave:



### Wave soldering profiles

Wired connection elements should be processed in accordance with the DIN EN 61760-1 standard. We have included two recommendations for practical wave soldering profiles, with which Weidmüller PCB terminals and connectors are qualified.

When choosing a suitable profile for your application, the following factors also need to be considered:

- PCB thickness
- Proportion of Cu in the layers
- Single/double-sided assembly
- Product range
- Heating and cooling rates

The single and double wave profiles each indicate the recommended operating range, including the maximum soldering temperature of 260°C. In practice, the maximum soldering temperature is quite often well below the above maximum profile.