

Device connector, front mounting - PV-FT-CCM-6-R1000



1704928

<https://www.phoenixcontact.com/in/products/1704928>

Please be informed that the data shown in this PDF document is generated from our Online Catalog. Please find the complete data in the user documentation. Our General Terms of Use for Downloads are valid.



Panel feed-through, Range of articles: Sunclix, Device connector, front mounting, number of positions: 1, min. conductor cross section: 6 mm², Connection method: Crimp, Type of contact: Pin

Your advantages

- High-quality materials ensure a high degree of reliability and long-term stability
- Maximum system efficiency with proven, low-loss SUNCLIX contacts
- International approvals enable worldwide use

Device connector, front mounting - PV-FT-CCM-6-R1000



1704928

<https://www.phoenixcontact.com/in/products/1704928>

Commercial Data

Item number	1704928
Packing unit	1,000 pc
Minimum order quantity	1,000 pc
Sales Key	ABL
Product Key	ABLBFA
Catalog Page	Page 421 (C-2-2013)
GTIN	4046356746212
Weight per Piece (including packing)	2.416 g
Weight per Piece (excluding packing)	4.6 g
Customs tariff number	85359000
Country of origin	DE

Device connector, front mounting - PV-FT-CCM-6-R1000



1704928

<https://www.phoenixcontact.com/in/products/1704928>

Technical Data

Notes

Safety note

Safety note

- **WARNING:** Commission properly functioning products only. The products must be regularly inspected for damage. Decommission defective products immediately. Replace damaged products. Repairs are not possible.
- **WARNING:** Only electrically qualified personnel may install and operate the product. They must observe the following safety notes. The qualified personnel must be familiar with the basics of electrical engineering. They must be able to recognize and prevent danger. The relevant symbol on the packaging indicates that only personnel familiar with electrical engineering are allowed to install and operate the product.
- **WARNING:** The connectors may not be plugged in or disconnected under load. Ignoring the warning or improper use may damage persons and/or property.
- The products are suitable for applications in plant, controller, and electrical device engineering.
- Assembled products may not be manipulated or improperly opened.
- Only use mating connectors that are specified in the technical data of the standards listed (e.g. the ones listed in the product accessories online at [phoenixcontact.com/products](https://www.phoenixcontact.com/products)).
- When using the product in direct connection with third-party manufacturers, the user is responsible.
- For operating voltages > 50 V AC, conductive connector housings must be grounded
- Ensure that the protective or functional ground has been properly connected.
- Observe the corresponding technical data. You will find information:
 - o On the product
 - o On the packing label
 - o In the supplied documentation
 - o Online at [phoenixcontact.com/products](https://www.phoenixcontact.com/products) under the product
- The installation notes/Design In documents online on the download page at [phoenixcontact.com/products](https://www.phoenixcontact.com/products) must be observed for this product.
- Use a protective cap to protect connectors that are not in use. The suitable accessories are available online in the accessory section of the product at [phoenixcontact.com/products](https://www.phoenixcontact.com/products)
- The connector warms up in normal operation. Depending on the ambient conditions, the surface of the connector can continue to warm up. In this case, the user is responsible for posting warnings (e.g. DIN EN ISO 13732-1:2008-12).
- Operate the connector only when it is fully plugged in and interlocked.
- Ensure that when laying the cable, the tensile load on the connectors does not exceed the upper limit specified in the standards.

Device connector, front mounting - PV-FT-CCM-6-R1000



1704928

<https://www.phoenixcontact.com/in/products/1704928>

- Observe the minimum bending radius of the cable. Lay the cable without twisting it.

Product properties

Product type	Panel feed-through
Number of positions	1
Insertion force	≤ 20 N (uninstalled state)

Insulation characteristics

Degree of pollution	2
---------------------	---

Dimensions

Dimensional drawing	
Width	7 mm
Height	7.7 mm
Length	28.8 mm

Electrical properties

Maximum load current	40 A (for 6 mm ²)
Rated voltage (II/2)	1000 V
Rated voltage (III/2)	1500 V
Rated surge voltage (II/2)	12 kV
Rated surge voltage (III/2)	12 kV
Rated surge voltage (III/3)	16 kV
Rated current (6.0 mm ²)	35 A
Contact resistance	0.45 mΩ
Contact resistance	≤ 0.45 mΩ (when plugged in)

Mechanical properties

Mechanical data

Insertion force	≤ 20 N (uninstalled state)
Withdrawal force	≤ 20 N (uninstalled state)

Material specifications

Flammability rating according to UL 94	V0
Insulating material group	I / CTI 600
Contact surface	Silver Ag
Contact material	Cu
Contact surface material	Ag

Connector

Insertion/withdrawal cycles	100
-----------------------------	-----

Device connector, front mounting - PV-FT-CCM-6-R1000



1704928

<https://www.phoenixcontact.com/in/products/1704928>

Cable / line

Cable structure

Single wire, cross section	6 mm ²
Stripping length of the individual wire	8 mm +1 mm

Ambient conditions

Degree of protection (when plugged in)	IP66 / IP68 (2 m / 24 h)
Degree of protection (not plugged in)	IP20
Ambient temperature (operation)	-40 °C ... 85 °C (installed with PV-...-HSG)
Ambient temperature (assembly)	-25 °C ... 50 °C

Device connector, front mounting - PV-FT-CCM-6-R1000



1704928

<https://www.phoenixcontact.com/in/products/1704928>

Drawings

Dimensional drawing

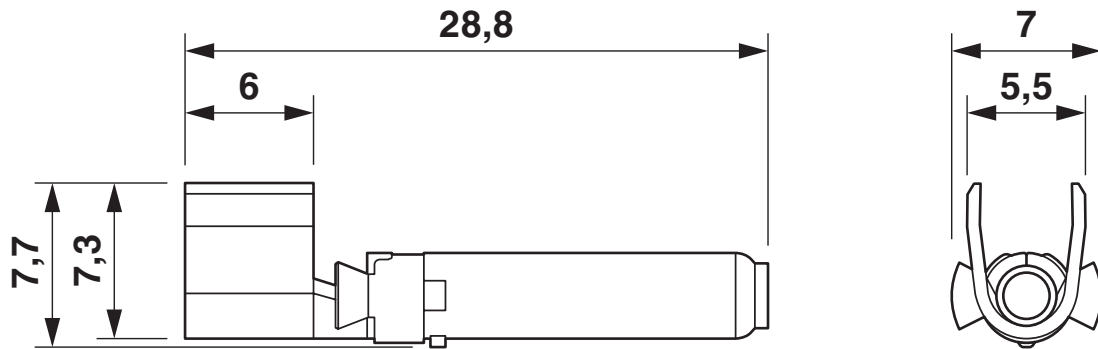

Dimensional drawing

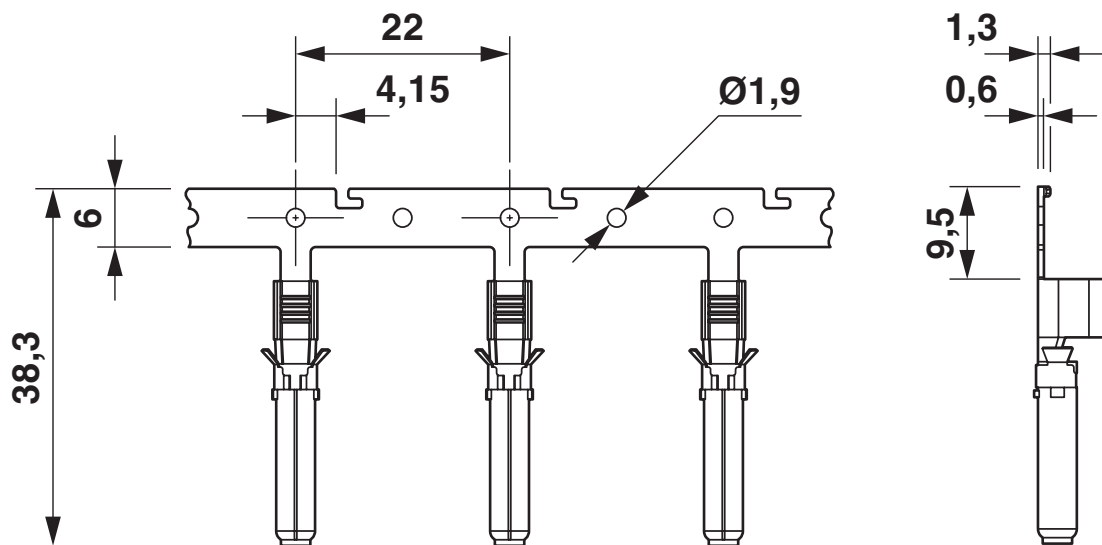

Device connector, front mounting - PV-FT-CCM-6-R1000



1704928

<https://www.phoenixcontact.com/in/products/1704928>

Classifications

ECLASS

ECLASS-9.0	27440204
ECLASS-10.0.1	27440204
ECLASS-11.0	27440204

ETIM

ETIM 8.0	EC000796
----------	----------

UNSPSC

UNSPSC 21.0	39121500
-------------	----------

Device connector, front mounting - PV-FT-CCM-6-R1000



1704928

<https://www.phoenixcontact.com/in/products/1704928>

Environmental Product Compliance

China RoHS	Environmentally friendly use period: unlimited = EFUP-e
	No hazardous substances above threshold values

Device connector, front mounting - PV-FT-CCM-6-R1000



1704928

<https://www.phoenixcontact.com/in/products/1704928>

Accessories

Assembly tool

Assembly tool - UNIFOX SR 6 - 1200137

<https://www.phoenixcontact.com/in/products/1200137>



Mounting pliers for snapping the SUNCLIX crimp contacts into the plastic housing, curved 35°, suitable for a conductor diameter of 4.2 mm ... 6.0 mm.

Photovoltaic connector

Photovoltaic connector - PV-FT-C2M-HSG - 1704925

<https://www.phoenixcontact.com/in/products/1704925>



Panel feed-through, Range of articles: Sunclix, Photovoltaic connector, housing material: PPE, color: black, number of positions: 1, rated voltage: 1000 V DC, rated current: 40 A, Connection method: Crimp, Type of contact: Pin

Device connector, front mounting - PV-FT-CCM-6-R1000

1704928

<https://www.phoenixcontact.com/in/products/1704928>

Protective cap

Protective cap - PV-C PROTECTION CAP - 1785430

<https://www.phoenixcontact.com/in/products/1785430>

Photovoltaic connector, Range of articles: Sunclix, Protective cap, color: black. self-sealing, without interlock, set consisting of: 1 protective cap for connector side and 1 protective cap for coupling side



Nut

Nut - PV-FT-C NUT BK - 1775880

<https://www.phoenixcontact.com/in/products/1775880>

Panel feed-through, Range of articles: Sunclix, Nut, number of positions: 0



Device connector, front mounting - PV-FT-CCM-6-R1000



1704928

<https://www.phoenixcontact.com/in/products/1704928>

Crimping pliers

Crimping pliers - CRIMPFOX-P SR 6 - 1212755

<https://www.phoenixcontact.com/in/products/1212755>



Crimping pliers, for SUNCLIX solar crimp connectors 2.5 ... 6 mm², unlockable pressure lock, precise parallel crimping, lateral entry, B crimp, incl. positioning tool

Phoenix Contact 2022 © - all rights reserved

<https://www.phoenixcontact.com>

PHOENIX CONTACT (I) Pvt. Ltd.

A-58/2, Okhla Industrial Area, Phase - II, New Delhi-110 020

+91.1275.71420

info@phoenixcontact.co.in